

SAFETY CONSIDERATIONS

GENERAL

This product and related documentation must be reviewed for familiarization with safety markings and instructions before operation. This product has been designed and tested in accordance with international standards.

SAFETY SYMBOLS



Instruction manual symbol: the product will be marked with this symbol when it is necessary for the user to refer to the instruction manual (refer to Table of Contents).



Indicates hazardous voltages.



Indicates earth (ground) terminal.

WARNING

The WARNING sign denotes a hazard. It calls attention to a procedure, practice, or the like, which, if not correctly performed or adhered to, could result in personal injury. Do not proceed beyond a WARNING sign until the indicated conditions are fully understood and met.

CAUTION

The CAUTION sign denotes a hazard. It calls attention to an operating procedure, practice, or the like, which, if not correctly performed or adhered to, could result in damage to or destruction of part or all of the product. Do not proceed beyond a CAUTION sign until the indicated conditions are fully understood and met.

SAFETY EARTH GROUND

This is a Safety Class I product (provided with a protective earthing terminal). An uninterruptible safety earth ground must be provided from the main power source to the product input wiring terminals, power cord, or supplied power cord set. Whenever it is likely that the protection has been impaired, the product must be made inoperative and be secured against any unintended operation.

BEFORE APPLYING POWER

Verify that the product is configured to match the available main power source per the input power configuration instructions provided in this manual.

If this product is to be energized via an autotransformer make sure the common terminal is connected to the neutral (grounded side of mains supply).

SERVICING

WARNING

Any servicing, adjustment, maintenance, or repair of this product must be performed only by qualified personnel.

Adjustments described in this manual may be performed with power supplied to the product while protective covers are removed. Energy available at many points may, if contacted, result in personal injury.

Capacitors inside this product may still be charged even when disconnected from its power source.

To avoid a fire hazard, only fuses with the required current rating and of the specified type (normal blow, time delay, etc.) are to be used for replacement.

VOLUME 2 CONTENTS

Section	Page	Section	Page
V ADJUSTMENTS	5-1	5-30. YO Loop Adjustments	5-45
5-1. Introduction	5-1	5-31. YO Delay Compensation, A54	5-50
5-3. Safety Considerations	5-1	5-32. 3.7 GHz Oscillator, A8	5-54
5-5. Equipment Required	5-1	5-33. Marker/Bandcross, A57	5-56
5-7. Adjustment Tools	5-1	5-34. Sweep Generator, A58	5-58
5-9. Factory Selected Components	5-1	5-35. Unleveled RF Output Adjustments	5-61
5-11. Related Adjustments	5-2	5-36. ALC Adjustments	5-75
5-13. Location of Test Points and Adjustments	5-2	5-36a. Slow Pulse Modulation Adjustment	5-86c
5-15. Accessing and Storing Calibration Constants	5-2	5-37. Leveled RF Output Adjustments	5-87
5-16. Introduction	5-2	5-38. Flatness Verification and Adjustment	5-102
5-18. Procedure to Access Calibration Constants	5-2	5-39. Pulse Adjustments	5-111
5-20. Procedure to Store the Calibration Constants	5-2	5-40. YO Loop Gain and Phase Margin Test and Adjustment	5-116
5-22. +22 VDC Power Supply, A35	5-18	VI REPLACEABLE PARTS	6-1
5-23. 10 MHz Standard Adjustment, A51	5-20	6-3. Exchange Assemblies	6-1
5-24. Omitted		6-5. Abbreviations	6-1
5-25. 100 MHz Voltage-Controlled Crystal Oscillator (VCXO), A30	5-24	6-7. Replaceable Parts List	6-1
5-26. M/N Loop, A32, A33, and A32A1	5-28	6-11. Ordering Information	6-2
5-27. 20/30 Loop Phase Lock, A36, A38, A39, A40, and A43	5-31	6-14. Spare Parts Kit	6-2
5-28. YO Pretune DAC, A54	5-41	VII MANUAL BACKDATING CHANGES	7-1
5-29. YO Main Driver, A55	5-43	7-1. Introduction	7-1

TABLES

Table	Page	Table	Page
5-1. Adjustment Procedures in Paragraph Order	5-3	5-8. Selected Values of Low Band Temperature Compensation Resistors in A25	5-78
5-2. Adjustable Components in Alpha-Numeric Order	5-4	5-9. High Band ALC Adjustment	5-82
5-3. Factory Selected Components	5-9	5-10. Low Band ALC Adjustment	5-83
5-4. Adjustment Interdependence Between Assemblies	5-10	5-11. Flatness in 2.4 to 26.5 GHz Range	5-107
5-5. HP Part Numbers of Standard Value Components	5-14	6-1. Exchange Parts	6-2
5-6. Selection Chart for Attenuator Resistors	5-27	6-1b. 2 Year Warranted Microcircuits	6-2
5-7. Selected Values of High Band Temperature Compensation Resistors in A25	5-78	6-2. Manufacturer's Code List, Reference Designations and Abbreviations	6-3
		6-3. Model 8340A Replaceable Parts	6-7
		7-1. Manual Backdating Changes by Serial Prefix	7-1
		7-2. Summary of Changes by Assembly	7-2

SECTION V ADJUSTMENTS

5-1. INTRODUCTION

5-2. This section provides adjustment procedures for the HP 8340A Synthesized Sweeper. These procedures should not be performed as routine maintenance but should be used (1) after replacement of a part or component, or (2) when performance tests show that the specifications of Table 1-1 cannot be met. Before attempting any adjustment, allow 1 hour warm-up time for the instrument. Table 5-1 lists the adjustment procedures by paragraph number in the order they appear in this Section. Table 5-2 lists all adjustable components by reference designator, name, and the function adjusted by each. Table 5-3 lists all factory selected components. Table 5-4 lists adjustment procedures that interact between assemblies. This table lists the adjustment paragraphs that must be checked when an assembly is adjusted, parts replaced, or the assembly replaced.

5-3. SAFETY CONSIDERATIONS

5-4. Although this instrument has been designed in accordance with international safety standards, this manual contains information, cautions, and warnings which must be followed to ensure safe operation and to retain the instrument in safe condition. Service and adjustments should be performed only by qualified service personnel.

WARNING

Adjustments in this section are performed with power supplied to the instrument while protective covers are removed. There are voltages at many points in the instrument which can, if contacted, cause personal injury. Be extremely careful. Adjustments should be performed only by trained service personnel.

Power is still applied to this instrument with the LINE switch in STANDBY. There is no OFF position on the LINE switch. Before removing or installing any assembly or printed circuit board, remove the power cord from the rear of both instruments.

Capacitors inside the instrument may still be charged, even if the instrument has been disconnected from its source of supply. Use a non-metallic adjustment tool whenever possible.

5-5. EQUIPMENT REQUIRED

5-6. Table 1-4 lists the equipment required for the adjustment procedures. If the test equipment recommended is not available, other equipment may be used if its performance meets the "Critical Specifications" listed in the table. The test setup used for an adjustment procedure is referenced in each procedure.

5-7. ADJUSTMENT TOOLS

5-8. For adjustments requiring a non-metallic tuning tool, use fiber tuning tool, HP Part Number 8710-0033. In situations not requiring non-metallic tuning tools, an ordinary small screwdriver or other suitable tool is sufficient. However, use of a non-metallic adjustment tool whenever possible is recommended. Never try to force any adjustment control in the instrument. This is especially critical when tuning variable slug-tuned inductors and variable capacitors.

5-9. FACTORY SELECTED COMPONENTS

5-10. Factory selected components are identified with an asterisk on the schematic diagram. The range of their values and functions are listed in Table 5-3. Part Numbers for selected values are located in Table 5-5.

5-11. RELATED ADJUSTMENTS

5-12. Any adjustments which interact with or are related to other adjustments are indicated in the adjustment procedures. It is important that adjustments so noted are performed in the order indicated to ensure that the instrument meets its specifications.

5-13. LOCATION OF TEST POINTS AND ADJUSTMENTS

5-14. Illustrations showing the locations of assemblies containing adjustments and locations of those adjustments within the assemblies are contained within the adjustment procedures where they apply. Also, major assembly and component location illustrations are located at the rear of Volumes 3 and 4 of this manual.

5-15. ACCESSING AND STORING CALIBRATION CONSTANTS**5-16. Introduction**

5-17. The HP 8340A contains three memory areas reserved for calibration constants. These areas are (1) working, (2) protected, and (3) default. A detailed description of these memory areas is contained in Section 8 under the heading "Calibration Constants." When performing adjustments in Section 5, some calibration constants in the "working memory area" are changed or "adjusted" to optimize performance parameters. Once these calibration constants are set for best instrument performance, the new values should be copied from the "working memory area" to the "protected memory area." This calibration data then may be used later in case of loss of valid calibration constants data in the "working memory area."

5-18. Procedure to Access Calibration Constants

5-19. In the adjustment procedures, calibration constants stored in HP 8340A working memory will be changed (adjusted). A calibration constant can be accessed by pushing the following key sequence:

[SHIFT] [GHz] [number of the Calibration Constant, 0 to 99]

[SHIFT] [MHz] [1] [2] [Hz]

[SHIFT] [kHz] [2] [2] [Hz]

The ENTRY DISPLAY will indicate the calibration constant number on the left and the present value on the right. Use the STEP keys to select a different calibration constant number. The ENTRY keyboard or the front panel rotary knob can be used to change the value. After the new value has been entered, press the [Hz] key to retain the new values in "working memory area."

5-20. Procedure to Store the Calibration Constants

5-21. After adjustments of the calibration constants are completed, the data thus stored in the "working memory area" should be copied to the "protected memory area" by pressing the following key sequence:

[SHIFT] [MHz] [1] [4] [Hz]

[SHIFT] [kHz] [5] [3] [4] [9] [Hz]

Wait for "CALIBRATION RESTORED" to be displayed in the ENTRY DISPLAY and then press [INSTR PRESET].

Table 5-1. Adjustment Procedures in Paragraph Order

Paragraph	Title	Page
5-22	+22 Vdc Power Supply, A35	5-18
5-23	10 MHz Standard, A51	5-20
5-24	Omitted	5-23
5-25	100 MHz Voltage-Controlled Crystal Oscillator (VCXO), A30	5-24
5-26	M/N Loop, A23, A33, and A32A1	5-28
5-27	20/30 Loop Phase Lock, A36, A38, A39, A40, and A43	5-31
5-28	YO Pretune DAC Gain, A54	5-41
5-29	YO Main Driver, A55	5-43
5-30	YO Loop Adjustment	5-45
5-31	YO Delay Compensation, A54	5-50
5-32	3.7 GHz Oscillator, A8	5-54
5-33	Marker/Bandcross, A57	5-56
5-34	Sweep Generator, A58	5-58
5-35	Unleveled RF Output Adjustments	5-61
5-36	ALC Adjustments	5-75
5-37	Leveled RF Output Adjustments	5-87
5-38	Flatness Verification and Adjustment	5-102
5-39	Pulse Adjustments ¹	5-111
5-40	YO Loop Overall Phase and Gain	5-116

¹ This Adjustment is not applicable to instruments equipped with Option 006, Delete Pulse Modulation.

Table 5-2. Adjustable components in Alpha-Numeric Order (1 of 5)

Reference Designator	Adjustment Name	Adjustment Paragraph Number	Adjustment Function
A8C4	PEAK	5-32	Peaks 100 MHz amplifier.
A8R8	BAL	5-32	Adjusts balance in Sampler.
A14A1R11	G1		Factory adjustment only. Sets gate bias on Bands 1 - 4 Power Amplifier.
A14A1R13	G3L		
A14A1R14	G2		
A14A1R15	G3R		
A14A1R16	G4L		
A14A1R18	G4R		
A16A1R4	G1		Factory adjustment only. Sets gate bias on Band 0 - 4 Modulator Splitter.
A16A1R6	G2		
A21R21	ON DELAY	5-39	Sample/Hold on delay is set to 100 to 180 nsec width at TP1.
A21R23	OFF DELAY	5-39	Sample/Hold off delay is set to 60 to 130 nsec width at TP1.
A24R1	OFF A	5-35, 5-37	Sets offset of modulator voltage clamp at beginning of band.
A24R2	OFF B	5-35, 5-37	Sets offset of modulator voltage clamp at end of band.
A24R3	X2A	5-35	Sets SRD Bias at maximum power at beginning of Band 2.
A24R4	X2B	5-35	Sets SRD bias at maximum power at end of Band 2.
A24R5	X2C	5-35, 5-37	Adjusts the relationship between bias voltage and power.
A24R6	X3A	5-35	Sets SRD Bias at maximum power at beginning of Band 3.
A24R7	X3B	5-35	Sets SRD Bias at maximum power at end of Band 3.

Table 5-2. Adjustable Components in Alpha-Numeric Order (2 of 5)

Reference Designator	Adjustment Name	Adjustment Paragraph Number	Adjustment Function
A24R8	X3C	5-35, 5-37	Adjusts the relationship between bias voltage and power.
A24R9	X4A	5-35	Sets SRD Bias at maximum power at beginning of Band 4.
A24R10	X4B	5-35	Sets SRD Bias at maximum power at end of Band 4.
A24R11	X4C	5-36, 5-37	Adjusts the relationship between bias voltage and power.
A24R12	MIN	5-36, 5-37	Sets minimum SRD Bias voltage.
A25R24	+20	5-36	Adjusts for +20 dBm.
A25R33	L-20	5-36	Adjusts for -20 dBm in Band 0.
A25R34	H-20	5-36	Adjusts for -20 dBm in Bands 1 through 4.
A25R38	L+10	5-36	Adjusts for +10 dBm in Band 0.
A25R39	H+10	5-36	Adjusts for +10 dBm in Bands 1 through 4.
A25R58	BAL	5-39	Adjusted to balance out charge injection in Sample/Hold circuit.
A25R80	EX-	5-36	Adjusts offset of U10 for negative input. (This must be adjusted before A25R84 EX+.
A25R84	EX+	5-36	Adjusts offset of U6 for positive input. (A25R80 EX- must be adjusted before making this adjustment.)
A25R88	EXHI	5-36	Sets high power level in External Leveling mode.
A25R108	LOFS	5-36, 5-38	Adjusts the logger output in Band 0 to equal the logger output in Bands 1 through 4 at 0 dBm.
A26R7	BAL	5-39	Adjusted to balance out charge injection in Sample/Hold circuit.
A26R43	HET	5-37	Adjusts ALC Loop Gain for Band 0.
A26R45	X1	5-37	Adjusts Loop Gain for Band 1.
A26R47	X2	5-37	Adjusts ALC Loop Gain for Band 2.
A26R49	X3	5-37	Adjusts ALC Loop Gain for Band 3.

Table 5-2. Adjustable Components in Alpha-Numeric Order (3 of 5)

Reference Designator	Adjustment Name	Adjustment Paragraph Number	Adjustment Function
A26R51	X4	5-37	Adjusts ALC Loop Gain for Band 4.
A26R88	MO	5-35, 5-37	Offsets current into Modulator Driver.
A26R91	AM GAIN	5-36	Sets gain of AM Modulation for 70.7% Modulation.
A26R96	SLOW PULSE	5-36a	Adjusts Slow Pulse rise/fall time, overshoot.
A27R4	BKPT1	5-38	Sets break point 1.
A27R8	BKPT2	5-38	Sets break point 2.
A28R1	OFF	5-35, 5-37	Sets overall offset for SYTM tracking.
A28R2	BP1	5-35, 5-37	Sets slope of the 13.5 GHz break point.
A28R3	BP2	5-35, 5-37	Sets slope of 20 GHz break point.
A28R4	BP3	5-35, 5-37	Sets slope of adjustable break point.
A28R5	BP3FRQ	5-35, 5-37	Sets frequency of adjustable break point. (Approximate range is 22 to 26.5 GHz.)
A28R6	DYO	5-35	Sets delay offset.
A28R7	DYS	5-35	Sets delay slope.
A28R8	GAIN	5-35, 5-37	Sets overall SYTM tracking gain.
A28R9	LKCK	5-35	Sets threshold of low frequency kick pulse.
A28R10	HKCK	5-35	Sets threshold of high frequency kick pulse.
A28R85	+10 ADJ	5-35	Sets +10V Reference Voltage.
A28R113	B1OFF	5-35, 5-37	Sets offset of Band 1.
A30C1	400 MHz	5-25	Peaks 400 MHz Amplifier.
A30C2	400 MHz	5-25	Peaks 400 MHz Amplifier.

Table 5-2. Adjustable Components in Alpha-Numeric Order (4 of 5)

Reference Designator	Adjustment Name	Adjustment Paragraph Number	Adjustment Function
A30C3	400 MHZ	5-25	Sets Quadrupler to 400 MHz output.
A30C4	100 MHZ	5-25	Sets 100 MHz Oscillator Frequency.
A32A2C1	FREQ ADJ	5-26	Adjusts frequency of oscillator for range of 355 to 395 MHz.
A32A2C5	PWR	5-26	Adjusts power output of VCO ≥ 0 dBm at output of A32.
A35R3	+22 ADJ	5-22	Sets regulated +22 V power supply output voltage.
A36L7	50 kHz NULL	5-27	Adjusts for maximum null at 50 kHz.
A36L8	50 kHz NULL	5-27	Adjusts for maximum null at 50 kHz.
A38L11	165 MHZ NULL	5-27	Adjusts for maximum null of 165 MHz signal.
A38L12	160 MHZ NULL	5-27	Adjusts for maximum null of 160 MHz signal.
A38L13	170 MHZ NULL	5-27	Adjusts for maximum null of 170 MHz signal.
A39C50	160 MHZ PEAK	5-27	Peaks 160 MHz output of X1.6 multiplier.
A39L11	VCO CENTER FREQUENCY	5-27	Centers PLL3 VCO frequency for range of 160 to 166 MHz output.
A39L16	160 MHZ PEAK	5-27	Peaks circuit at 160 MHz. Interacts with L17.
A39L17	160 MHZ PEAK	5-27	Peaks circuit at 160 MHz. Interacts with L16.
A40R2	150 MHZ ADJUST	5-27	Adjusts VCO TUNE voltage at 150 MHz.
A40R4	100 MHZ ADJUST	5-27	Adjusts VCO TUNE voltage at 100 MHz.
A43R9	0.3 MHZ ADJUST	5-27	Sets discriminator gain at 0.3 MHz.
A43R25	0.5 MHZ ΔF	5-27	Adjusts 20/30 sweep frequency ΔF accuracy.
A43R27	5 MHZ ΔF	5-27	Adjusts 20/30 sweep frequency ΔF accuracy.
A43R41	0.2 MHZ ADJUST	5-27	Sets pretune DAC offset at 0.2 MHz.

Table 5-2. Adjustable Components in Alpha-Numeric Order (5 of 5)

Reference Designator	Adjustment Name	Adjustment Paragraph Number	Adjustment Function
A48C1	Response	5-30	Adjusts Sampler Drive Amplifier output network for best response.
A48C2	Response	5-30	Adjusts Sampler Drive Amplifier output network for best response.
A48R1	IF GAIN	5-30	Adjusts IF gain for 0 to +8 dBm output from Output Amplifier.
A51	COURSE	5-23	Adjusts 10 MHz Reference Oscillator frequency.
A51	FINE	5-23	Adjusts 10 MHz Reference Oscillator frequency.
A54R14	PGN	5-28	Adjusts pretune gain for +2.10V/GHz.
A54R22	POFF	5-28	Adjusts pretune offset for -2.5V/GHz at output of Summing Amplifier.
A54R30	CGN	5-31	Adjusts gain compensation for YO delay.
A54R32	COFF	5-31	Adjusts offset compensation for YO delay.
A54R36	PW	5-31	Adjusts pulse width of YO Retrace Kick Pulse.
A55R4	GAIN	5-29	Adjusts input level of Pretune signal for -2.34V/GHz at TP5.
A55R47	OFFSET	5-29	Sets crossover point of Summing Amplifier.
A57R32	10V END OF SWP ADJ	5-33	Adjusts marker ramp for 10V at end of sweep.
A57R1	MAN GAIN	5-33	Adjusts output range of manual sweep DAC.
A58R4	SWP TIME	5-34	Adjusts sweep time of ramp generator.
A58R13	SWP GAIN	5-34	Adjusts gain of summing amplifier for +2V/GHz ramp.
A58R33	RESET	5-34	Adjusts Reset DAC for minimum at error test point.

Table 5-3. Factory Selected Components

Reference Designator	Range of Values	Adjustment Paragraph Number	Function of Component
A25C11	Either 0 or 1000 PF	5-36	Selected for optimum Log-Amp speed and stability
A25R36	4640 - 9090 Ohms	5-36	} Adjusts temperature compensation of HI Band } detector.
A25R37	3830 - 6190 Ohms	5-36	
A25R109	1620 - 3830 Ohms	5-36	} Adjusts temperature compensation of LO Band } detector.
A25R115	4640 - 9090 Ohms	5-36	
A30C8	5.6 - 11 PF	5-25	Sets range of C4 so midposition is 100 MHz.
A30L4	0.22 - 0.68 mH	5-25	Centers Oscillator at 100 MHz.
A30R67	110 - 825 Ohms	5-25	Part of attenuator to set 400 MHz output at -10 dBm.
A30R68	6.8 - 61.9 Ohms	5-25	Part of attenuator to set 400 MHz output at -10 dBm.
A30R69	110 - 825 Ohms	5-25	Part of attenuator to set 400 MHz output at -10 dBm.
A39C49	8.2 - 16 PF	5-27	Sets range of C50 so midposition is 160 MHz.
A48C22	100 - 160 PF	5-30	Selected to tune RLC network at input of Buffer Amplifier to 25 MHz passband.
A48R22	6.2 - 23.7 Ohms	5-30	Selected to adjust resistance of RLC network at input of Buffer Amplifier for passband bandwidth of 18 to 32 MHz.

Table 5-4. Adjustment Interdependence Between Assemblies (1 of 4)

Assembly Adjusted or Replaced	Associated Adjustments That Must Be Made	Procedure Paragraphs
A1 Alpha Display	None	
A2 Display Driver	None	
A3 Display Processor	None	
A4 Not Assigned		
A5 Keyboard	None	
A6 Keyboard Interface	None	
A7 Lower Keyboard	None	
A8 3.7 GHz Oscillator	Band Zero ALC Loop Gain	5-32; 5-37, steps 19 thru 21.
A9 Band Zero Pulse Modulator	None	
A10 Directional Coupler	Flatness Adjustment	5-38, steps 10 thru 31.
A11 Bands 1-4 Detector	A25R36 and A25R37; Hi Band and Lo Band ALC Adjustment; Flatness; ADC Adjustment; Pulse	5-36, steps 1 thru 9, 15 thru 20; 5-38, steps 24 thru 31, 33 thru 37; 5-39.
A12 Band Zero Detector	Lo Band ALC, ADC, Flatness, A25R109, and A25R115.	5-36, steps 1 thru 4, 10 thru 14, 15 thru 20; 5-38, steps 29 thru 31, 36, and 37.
A13 SYTM	SYTM Tracking and SRD Bias Adjustment	5-35 and 5-37
A14 Band 1 - 4 Power Ampl.	SRD Bias and ALC Loop Gain.	5-35 and 5-37, A24 and A26 adjustments only.
A15 Band Zero Low-Pass Filter	None	
A16 Band 1 - 4 Modulator/Splitter	SRD Bias and ALC Loop Gain.	5-35 and 5-37, A24 and A26 adjustments only.

Table 5-4. Adjustment Interdependence Between Assemblies (2 of 4)

Assembly Adjusted or Replaced	Associated Adjustments That Must Be Made	Procedure Paragraphs
A17 Band Zero Mixer	None	
A18 Band Zero Power Ampl.	None	
A19 Capacitor Assembly	None	
A20 RF Section Filter	None	
A21 Pulse Modulator Driver	Pulse Adjustment	5-39.
A22 Not Assigned		
A23 Not Assigned		
A24 Attenuator Driver/SRD Bias	SRD Bias Adjustment	5-35 and 5-37, A24 adjustments only.
A25 ALC Detector	ALC, ADC, Pulse, and External Leveling Adjustment	5-36; 5-38, steps 33 thru 37; 5-39.
A26 Linear Modulator	Loop Gain, SRD Bias, Integrator Gate Balance.	5-37; 5-39, steps 14 and 15.
A27 Level Control	Flatness, ALC, and ADC Adjustment	5-36 and 5-38.
A28 SYTM Driver	SYTM Tracking and SRD Bias Adjustment	5-35 and 5-37.
A29 Reference Phase Detector	None	
A30 100 MHz VCXO	A30C1 thru C4	5-25.
A31 M/N Phase Detector	None	
A32 M/N VCO	A32A2C1, A32A2C5	5-26.
A33 M/N Output	None	
A34 Reference—M/N Mother Board	None	

Table 5-4. Adjustment Interdependence Between Assemblies (3 of 4)

Assembly Adjusted or Replaced	Associated Adjustments That Must Be Made	Procedure Paragraphs
A35 Rectifier	+22V Supply	5-22.
A36 PLL1 VCO	A36L7, A36L8	5-27, steps 44 thru 61
A37 PLL1 Divider	None	
A38 PLL1 IF	A38L11 thru A38L13.	5-27, steps 62 thru 76
A39 PLL3 Upconverter	A39C50, A39L4, L16, L17	5-27, steps 32 thru 43
A40 PLL2 VCO	PLL2 Adjustments	5-27, steps 1 thru 31.
A41 PLL2 Phase Detector	None	
A42 PLL2 Divider	None	
A43 PLL2 Discriminator	PLL2 Adjustments	5-27, steps 1 thru 31.
A44 YIG Oscillator	YO Adjustment, Delay Adjustment, and YTM Delay.	5-29; 5-31; and 5-35, steps 13 thru 24.
A45 Pre-Leveler	YTM Bias	5-35 and 5-37, A24 adjustments only.
A46 7 GHz Low-Pass Filter	None	
A47 Sense Resistor Assembly	YO Adjustment and Delay, and YTM Adjustment and Delay.	5-29, 5-31, 5-35, and 5-37.
A48 YO Loop Sampler	Sampler Adjustment	5-30
A49 YO Loop Phase Detector	None	
A50 YO Loop Interconnect	None	
A51 Reference Oscillator	10 MHz Standard Adjustment	5-23
A52 Positive Regulator	None	

Table 5-4. Adjustment Interdependence Between Assemblies (4 of 4)

Assembly Adjusted or Replaced	Associated Adjustments That Must Be Made	Procedure Paragraphs
A53 Negative Regulator	None	
A54 YO Pretune DAC/Delay Compensation	YO Pretune, YO Main Driver, and YO Delay Compensation, SYTM Delay Compensation.	5-28, 5-29, 5-31, 5-35 and 5-37.
A55 YO Driver	YO Adjustment	5-29.
A56—15V Regulator	None	
A57 Marker/Bandcross	Marker Bandcrossing Adjustment	5-33.
A58 Sweep Generator	Sweep Generator Adjustment	5-34.
A59 Digital Interface	None	
A60 Processor	None	
A61 Memory	None	
A62 Main Mother Board	None	
A63 70 dB RF Attenuator	Flatness RF Attenuator Calibration	5-38, steps 10 thru 31. For RF Attenuator Calibration, see manual supplement titled "Automated Test Procedures".

Table 5-5. HP Part Numbers of Standard Value Components (1 of 4)

CAPACITORS					
RANGE: 1 to 24 pF TYPE: Tubular TOLERANCE: 1 to 9.1 pF = $\pm 25\%$ 10 to 24 pF = $\pm 5\%$			RANGE: 27 to 680 pF TYPE: Dipped Mica TOLERANCE: $\pm 5\%$		
					
Value (pF)	HP Part Number	C D	Value (pF)	HP Part Number	C D
1.0	0160-2236	8	27	0160-2306	8
1.2	0160-2237	9	30	0160-2199	2
1.5	0150-0091	8	33	0160-2150	5
1.8	0160-2239	1	36	0160-2308	5
2.0	0160-2240	4	39	0140-0190	7
2.2	0160-2241	5	43	0160-2200	6
2.4	0160-2242	6	47	0160-2307	4
2.7	0160-2243	7	51	0160-2201	7
3.0	0160-2244	8	56	0140-0191	8
3.3	0150-0059	8	62	0140-0205	5
3.6	0160-2246	0	68	0140-0192	9
3.9	0160-2247	1	75	0160-2202	8
4.3	0160-2248	2	82	0140-0193	0
4.7	0160-2249	3	91	0160-2203	9
5.1	0160-2250	6	100	0160-2204	0
5.6	0160-2251	7	110	0140-0194	1
6.2	0160-2252	8	120	0160-2205	1
6.8	0160-2253	9	130	0140-0195	2
7.5	0160-2254	0	150	0140-0196	3
8.2	0160-2255	1	160	0160-2206	2
9.1	0160-2256	2	180	0140-0197	4
10.0	0160-2257	3	200	0140-0198	5
11.0	0160-2258	4	220	0160-0134	1
12.0	0160-2259	5	240	0140-0199	6
13.0	0160-2260	8	270	0140-0210	2
15.0	0160-2261	9	300	0160-2207	3
16.0	0160-2262	0	330	0160-2208	4
18.0	0160-2263	1	360	0160-2209	5
20.0	0160-2264	2	390	0140-0200	0
22.0	0160-2265	3	430	0160-0939	4
24.0	0160-2266	4	470	0160-3533	0
			510	0160-3534	1
			560	0160-3535	2
			620	0160-3536	3
			680	0160-3537	4

Table 5-5. HP Part Numbers of Standard Value Components (2 of 4)

RESISTORS								
RANGE: 10 to 464K Ohms TYPE: Fixed-Film WATTAGE: .125 at 125°C TOLERANCE: ±1.0%								
Value (Ω)	HP Part Number	C D	Value (Ω)	HP Part Number	C D	Value (Ω)	HP Part Number	C D
10.0	0757-0346	2	464	0698-0082	7	21.5K	0757-0199	3
11.0	0757-0378	0	511	0757-0416	7	23.7K	0698-3158	4
12.1	0757-0379	1	562	0757-0417	8	26.1K	0698-3159	5
13.3	0698-3427	0	619	0757-0418	9	28.7K	0698-3449	6
14.7	0698-3428	1	681	0757-0419	0	31.6K	0698-3160	8
16.2	0757-0382	6	750	0757-0420	3	34.8K	0757-0123	3
17.8	0757-0294	9	825	0757-0421	4	38.3K	0698-3161	9
19.6	0698-3429	2	909	0757-0422	5	42.2K	0698-3450	9
21.5	0698-3430	5	1.0K	0757-0280	3	46.4K	0698-3162	0
23.7	0698-3431	6	1.1K	0757-0424	7	51.1K	0757-0458	7
26.1	0698-3432	7	1.21K	0757-0274	5	56.2K	0757-0459	8
28.7	0698-3433	8	1.33K	0757-0317	7	61.9K	0757-0460	1
31.6	0757-0180	2	1.47K	0757-1094	9	68.1K	0757-0461	2
34.8	0698-3434	9	1.62K	0757-0428	1	75.0K	0757-0462	3
38.3	0698-3435	0	1.78K	0757-0278	9	82.5K	0757-0463	4
42.2	0757-0316	6	1.96K	0698-0083	8	90.9K	0757-0464	5
46.4	0698-4037	0	2.15K	0698-0084	9	100K	0757-0465	6
51.1	0757-0394	0	2.37K	0698-3150	6	110K	0757-0466	7
56.2	0757-0395	1	2.61K	0698-0085	0	121K	0757-0467	8
61.9	0757-0276	7	2.87K	0698-3151	7	133K	0698-3451	0
68.1	0757-0397	3	3.16K	0757-0279	0	147K	0698-3452	1
75.0	0757-0398	4	3.48K	0698-3152	8	162K	0757-0470	3
82.5	0757-0399	5	3.83K	0698-3153	9	178K	0698-3243	8
90.0	0757-0400	9	4.22K	0698-3154	0	196K	0698-3453	2
100	0757-0401	0	4.64K	0698-3155	1	215K	0698-3454	3
110	0757-0402	1	5.11K	0757-0438	3	237K	0698-3266	5
121	0757-0403	2	5.62K	0757-0200	7	261K	0698-3455	4
133	0698-3437	2	6.19K	0757-0290	5	287K	0698-3456	5
147	0698-3438	3	6.81K	0757-0439	4	316K	0698-3457	6
162	0757-0405	4	7.50K	0757-0440	7	348K	0698-3458	7
178	0698-3439	4	8.25K	0757-0441	8	383K	0698-3459	8
196	0698-3440	7	9.09K	0757-0288	1	422K	0698-3460	1
215	0698-3441	8	10.0K	0757-0442	9	464K	0698-3260	9
237	0698-3442	9	11.0K	0757-0443	0			
261	0698-3132	4	12.1K	0757-0444	1			
287	0698-3443	0	13.3K	0757-0289	2			
316	0698-3444	1	14.7K	0698-3156	2			
348	0698-3445	2	16.2K	0757-0447	4			
383	0698-3446	3	17.8K	0698-3136	8			
422	0698-3447	4	19.6K	0698-3157	3			

Table 5-5. HP Part Numbers of Standard Value Components (4 of 4)

FIXED COIL					
Tolerance: 10% Unshielded					
Value	HP Part Number	C D	Value	HP Part Number	C D
1 MH	9140-0137	1	390 NH	9100-2254	3
5 MH	9140-0072	3	470 NH	9100-2255	4
10 MH	9140-0131	5	560 NH	9100-2232	7
24 MH	9100-2867	4	680 NH	9140-0141	7
50 NH	9100-2891	4	820 NH	9100-2257	6
51 NH	9135-0073	3	1.2 UH	9100-2258	7
68 NH	9135-0081	3	1.8 UH	9100-2260	1
100 NH	9100-2247	4	2.2 UH	9140-0098	3
120 NH	9100-2248	5	3.3 UH	9140-0111	1
			4.7 UH	9140-0144	0
150 NH	9100-2249	6			
180 NH	9100-2250	9	5.6 UH	9100-1618	1
220 NH	9100-2251	0			
270 NH	9100-2252	1			
330 NH	9100-0368	6			

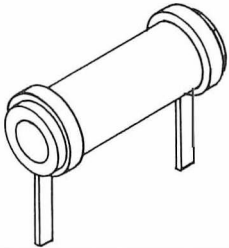
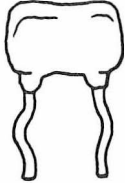
5-22. +22 VDC POWER SUPPLY, A35**Reference:**

Performance Test: None
 Service Section: Power Supplies

Description:

The +22V supply is adjusted for +22 Vdc.

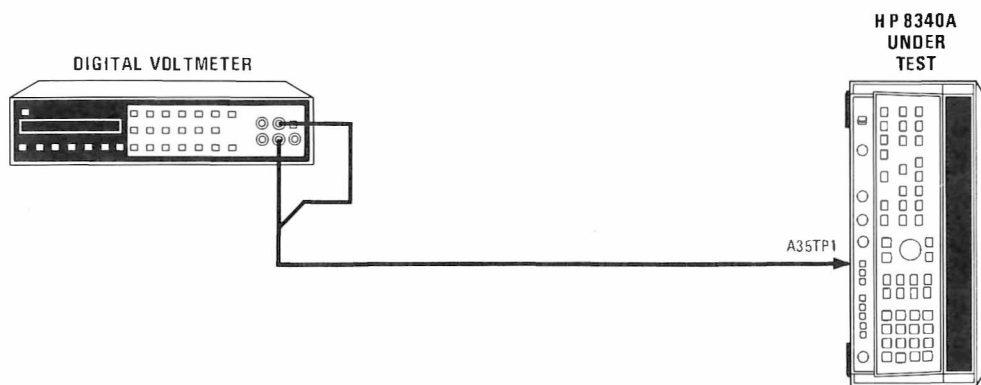

Figure 5-1. +22 Volt Power Supply Adjustments Setup

Equipment Required:

Digital Voltmeter HP 3455A

Procedure:

1. Position 8340A in the test position and connect equipment as shown in Figure 5-1.
2. Set LINE switch to ON.
3. The yellow +22V indicator on A35 should be lit.
4. The DVM indication should be $+22.000 \pm 0.010$ Vdc. If the indication is out of tolerance, adjust A35R3 +22 ADJ control for the specified voltage.

5-22. +22 VDC POWER SUPPLY, A35 (Cont'd)

8340A BOTTOM VIEW

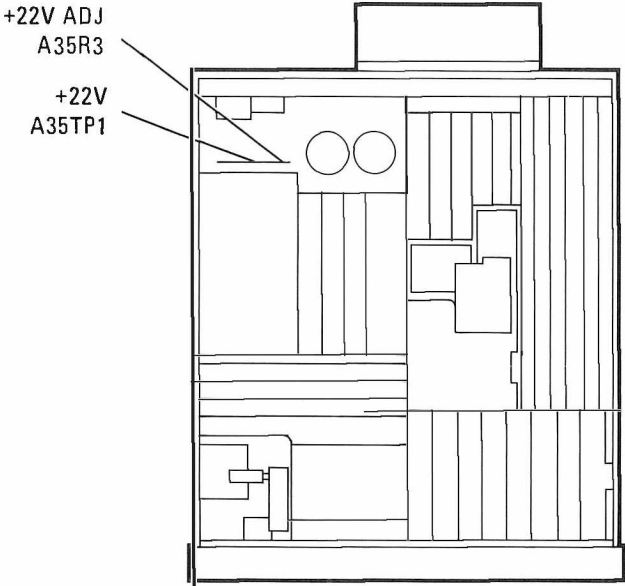

Figure 5-2. +22V Power Supply Adjustment Locations

5-23. 10 MHz STANDARD ADJUSTMENT, A51**Reference:**

Performance Test: None

Service Section: Reference — M/N Loops

Description:

The internal 10 MHz time base is adjusted for frequency accuracy. This procedure does not adjust for long-term drift or aging rate. It adjusts only short-term accuracy. To properly adjust the time base, a frequency standard whose accuracy is known to be better than that of the 8340A Time Base is required. Refer to Frequency Reference specifications in Section I, Table 1-1 for aging rate specifications for the internal time base.

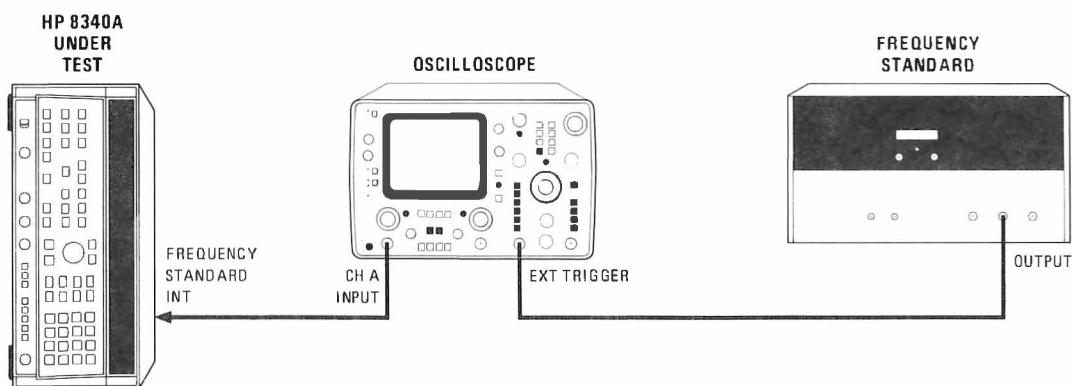

Figure 5-3. 10 MHz Standard Adjustment Setup

Equipment Required:

Oscilloscope..... HP 1741A
 Frequency Standard..... any 1, 2, 5, or 10 MHz Frequency Standard
 with aging rate of $\pm 1 \times 10^{-9}$ /day or better such as HP 5061A

Procedure:**NOTE**

Primary power must have been applied to the instrument for at least 30 days before adjusting the internal time base. If the instrument was disconnected from ac power less than 24 hours (after it had its initial 30 day warmup), the warmup time is 24 hours before adjusting internal time base.

NOTE

If front-panel red OVEN annunciator is lighted, do not make internal time base adjustments. This annunciator lights when the oven for the reference crystal oscillator is not at operating temperature. A cold oven can take 30 minutes to reach operating temperature; a warm oven that suddenly goes cold has lost power and requires service. Section VIII (Service) describes the action required to repair a faulty oven.

5-23. 10 MHz STANDARD ADJUSTMENT, A51 (Cont'd)

1. Connect equipment as shown in Figure 5-3 as follows:
 - a. At the 8340A, disconnect jumper from rear-panel FREQUENCY STANDARD INT connector.
 - b. Connect oscilloscope CH A to the 8340A FREQUENCY STANDARD INT connector. (If the oscilloscope being used does not have a 50 Ohm input like the Model 1741A, connect Channel A through a 50 Ohm feedthrough.)
 - c. Set switch adjacent to the INT connector to INT position.
 - d. Connect a frequency standard whose accuracy is known to be better than that of the internal time base, such as an HP 5061A Cesium Beam, to the EXT TRIGGER input of the oscilloscope.
 - e. Set LINE switch to ON.

2. Set oscilloscope controls as follows:

TIME/DIV.....	0.05μsec
CHAN A VOLTS/DIV	0.5
MAG x 10 pushbutton	OUT
DISPLAY A pushbutton.....	IN
TRIGGER COMP A/B.....	A
INT/EXT trigger pushbutton.....	IN
EXT Divide By 10	OUT
SWEEP VERNIER control	CAL
TRIGGER HOLDOFF.....	Fully Counterclockwise
AC/DC trigger pushbutton.....	OUT (AC)
POS/NEG trigger pushbutton.....	OUT (POS)
Main TRIGGER LEVEL control.....	Centered

3. Adjust Main TRIGGER LEVEL control as necessary to display sine-wave signal on oscilloscope.
4. Remove dust cap screws used to seal the adjustments from A51 10 MHz Standard.
5. Adjust A51 COARSE frequency adjust for minimum sideways movement of the displayed signal. Adjust A51 FINE frequency adjust for no sideways movement of displayed signal. Refer to Figure 5-4 for location of A51 10 MHz Standard.
6. Observe the sine wave signal on the oscilloscope for 100 seconds. The sine wave trace should move less than 1 cycle or 360 degrees.
7. Disconnect oscilloscope and reinstall dust cover screws over A51 adjustments. Reconnect rear panel cable between FREQUENCY STANDARD INT and EXT connectors.

5-23. 10 MHz STANDARD ADJUSTMENT, A51 (Cont'd)

Figure 5-4. 10 MHz Standard Adjustments Location

5-24. THIS TEST HAS BEEN OMITTED

5-25. 100 MHz VOLTAGE-CONTROLLED CRYSTAL OSCILLATOR (VCXO), A30

Reference:

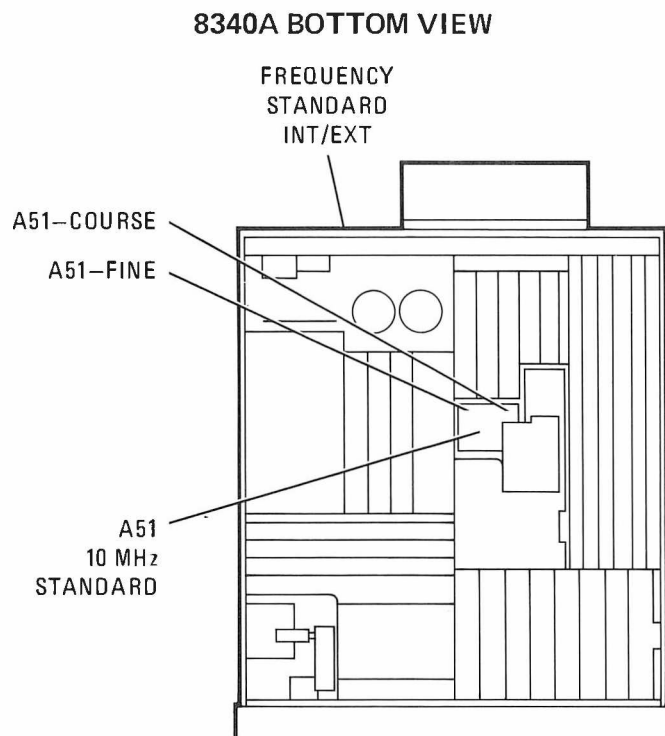
Performance Test: None
 Service Section: Reference – M/N Loops

Description:

The open loop frequency and maximum power output of the 100 MHz VCXO is centered around 100 MHz. The 400 MHz signal is adjusted for maximum 400 MHz output with minimum spurious output. The 400 MHz output is set to -10 dBm by selecting proper resistor values for the attenuator network A30R67, R68, and R69.

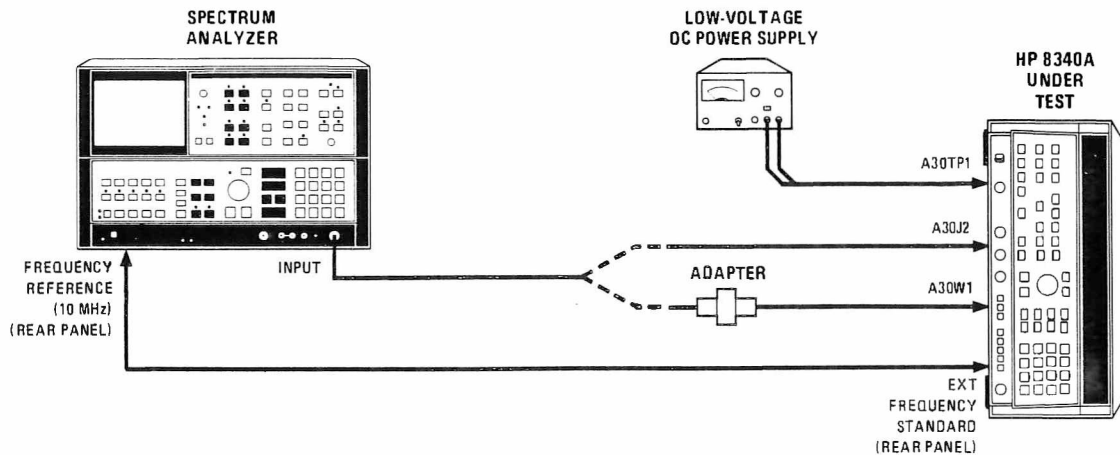

Figure 5-6. 100 MHz VCXO Adjustment Setup

Equipment Required:

- Spectrum Analyzer HP 8566A
- Low-Voltage DC Power Supply HP 6294A
- BNC to SMB Snap-On Test Cable (2 required) HP P/N 85680-60093
- Adapter, SMB Snap-On Male-to-Male HP P/N 1250-0069

Procedure:

1. Position HP 8340A in the Test Position as shown in Figure 5-6 with bottom cover removed. Connect equipment as shown in Figure 5-6. On the HP 8340A rear panel, disconnect BNC cable connected between INT and EXT Frequency Standard connectors, set INT/EXT switch to EXT, then connect cable from EXT connector to Spectrum Analyzer Frequency Reference (10 MHz) rear-panel connector. Allow instruments to warm up for one-half hour.

5-25. 100 MHz VOLTAGE-CONTROLLED CRYSTAL OSCILLATOR (VCXO), A30 (Cont'd)

2. Set Spectrum Analyzer controls as follows:

CENTER FREQ.....	100 MHz
REF LEVEL.....	3 dBm
ATTEN.....	+20 dB
LOG SCALE.....	1 dB/DIV
RES BW.....	300 Hz
VBW.....	300 Hz
FREQ SPAN.....	20 KHz
SWEEP TIME.....	1 SEC.
MARKER ENTRY.....	Press PEAK SEARCH
MARKER ENTRY.....	Press MKR→CF
MARKER MODE.....	Press SIGNAL TRACK

100 MHz OUTPUT ADJUSTMENT

3. Set LINE switch to ON and press [INSTR PRESET].
4. At rear panel of 8340A, disconnect 10 MHz Frequency Standard cable at EXT FREQUENCY STANDARD connector.
5. Jumper -10 Vdc from A53TP5 (-10V) to A30TP1 TUNE test point. Refer to Figure 5-7 for location of A30 and adjustments.

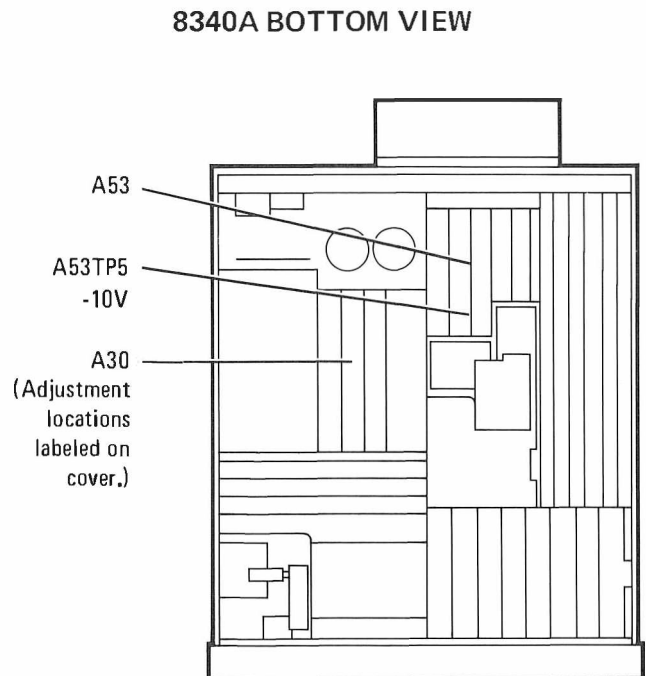

Figure 5-7. Location of A30 100 MHz VCXO Adjustments

5-25. 100 MHz VOLTAGE-CONTROLLED CRYSTAL OSCILLATOR (VCXO), A30 (Cont'd)

6. Disconnect cable W35 from A30J2 100 MHz OUT. Connect Spectrum Analyzer RF Input to A30J2.
7. Adjust A30C4 100 MHz ADJ through its full range while monitoring frequency indication on Spectrum Analyzer. Adjustment should provide a minimum adjustment range of plus and minus 300 Hz centered about 100 MHz. If adjustment does not provide sufficient range, select new values for factory selected components A30C8 and A30L4. A30L4 is used to center the adjustment about 100 MHz and A30C8 is used to adjust the range of A30C4. Refer to Table 5-3 for range of values. Refer to Table 5-5 for HP Part Numbers.
8. Adjust A30C4 100 MHz ADJ for Spectrum Analyzer indication of 100.0000 MHz ± 0.0001 MHz.
9. Disconnect cable A30W1 at A31J1 400 MHz IN and connect the open end of this cable (A30W1) to the Spectrum Analyzer input using a BNC to SMB Snap-on test cable and SMB male-to-male adapter. Set Spectrum Analyzer controls to view a 400 MHz signal.
10. The 400 MHz output should be -10 dBm ± 3 dB.
11. Disconnect jumper from -10 Vdc at A53TP5 and connect the jumper from A30TP1 TUNE test point to ground. Connect Spectrum Analyzer to A30J2. Adjust Spectrum Analyzer to view 100 MHz.
12. Frequency indication on Spectrum Analyzer should be less than 100 MHz. If not, repeat Steps 6 and 7.
13. Remove the jumper from A30TP1 to ground and connect A30TP1 TUNE to the output of an external low-voltage DC power supply. Set power supply for an output of -25 Vdc. Verify TUNE test point A30TP1 is at -25 Vdc.
14. Frequency indication on Spectrum Analyzer should be greater than 100 MHz. If not, repeat Steps 6 and 7 and verify that the oscillator range is 100 MHz ± 300 Hz. Disconnect power supply from A30TP1. Reconnect 10 MHz signal cable from Spectrum Analyzer to 8340A rear-panel EXT FREQUENCY STANDARD.

400 MHz OUTPUT ADJUSTMENT

15. Set Spectrum Analyzer to 500 MHz center frequency and 100 MHz frequency span per division.
16. Connect Spectrum Analyzer to A30W1 cable. Adjust A30C3, A30C2, and A30C1 400 MHz adjustments, in that order, to maximize the 400 MHz signal and minimize all harmonics of 100 MHz. Harmonics at 100, 300, 500, 600, 700, and 900 MHz must be greater than 40 dB down from the 400 MHz signal. Harmonics at 200 MHz must be greater than 25 dB down from the 400 MHz signal. Harmonics at 800 MHz must be greater than 15 dB down from the 400 MHz signal. It may be necessary to perform the adjustments more than once. This should be done in the order stated each time through the adjustments.

5-25. 100 MHz VOLTAGE-CONTROLLED CRYSTAL OSCILLATOR (VCXO), A30 (Cont'd)

17. The amplitude of the 400 MHz signal should be $-10 \text{ dBm} \pm 3 \text{ dB}$. This amplitude is set by selecting attenuator network resistors A30R67, A30R68, and A30R69.

Table 5-6. Selection Chart for Attenuator Resistors

Attenuation (dB)	Resistors (Ohms)		
	R67	R68	R69
0	Open	Short	Open
1	825	6.8	825
2	422	12.1	422
3	261	17.8	261
4	215	23.7	215
5	178	31.6	178
6	162	38.3	162
7	133	46.4	133
8	121	51.1	121
9	110	61.9	110

NOTE

HP Part Numbers for resistors may be found in Table 5-5.

18. If the amplitude of the 400 MHz signal is not within 3 dB of -10 dBm , note the amplitude and change the values of A30R67, A30R68, and A30R69 as necessary to adjust the amplitude to $-10 \text{ dBm} \pm 3 \text{ dB}$. Table 5-6 contains a list of attenuations in 1 dB steps and the corresponding values for the attenuator network resistors to adjust the level to -10 dBm . Refer to A30 service section for location of resistors.
19. Check the level of the 100 MHz harmonics as displayed on the Spectrum Analyzer. Harmonics at 100, 300, 500, 600, 700, and 900 MHz must be greater than 40 dB down from the 400 MHz signal. Harmonics at 200 MHz must be greater than 25 dB down from the 400 MHz signal. Harmonics at 800 MHz must be greater than 15 dB down from the 400 MHz signal. If not, repeat step 15.
20. Set the 8340A LINE switch to STANDBY. Disconnect equipment from 8340A and reconnect the two cables. Disconnect the 10 MHz Frequency Standard cable at the rear of the 8340A, reconnect jumper cable between INT and EXT, and set switch to INT. Set 8340A LINE switch to ON.

5-26. M/N LOOP, A32, A33, AND A32A1

Reference:

Performance Test: Frequency Range and CW Mode Accuracy

Service Section: Reference - M/N Loops

Description:

The M/N VCO tuning range is centered and the output level is set and checked to ensure an adequate RF output level across the band of the M/N output.

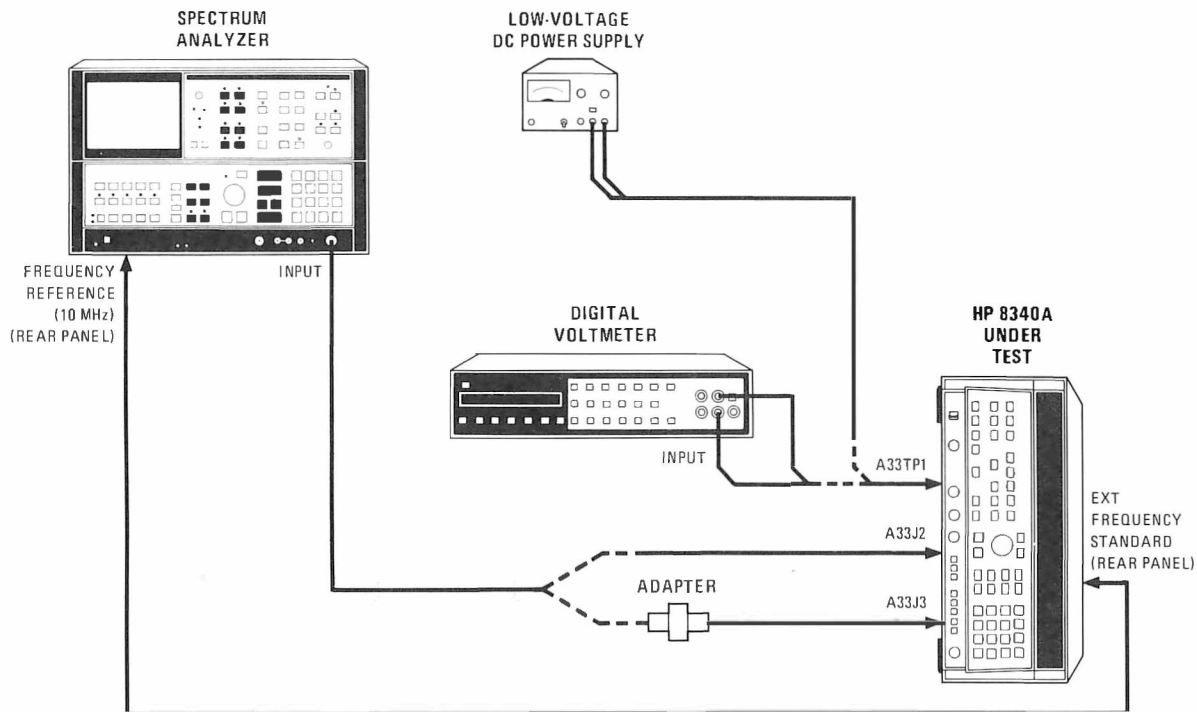

Figure 5-8. M/N Loop Adjustment Setup

Equipment Required:

Spectrum Analyzer.....	HP 8566A
Digital Voltmeter (DVM)	HP 3455A
Low-Voltage DC Power Supply.....	HP 6294A
BNC to SMB Snap-On Test Cable	HP P/N 85680-60093
Adapter, SMB Snap-On Male-to-Male	HP P/N 1250-0069

Procedure:

1. Position the 8340A in the test position as shown in Figure 5-8 with bottom cover removed. Connect equipment as shown in Figure 5-8. On the 8340A rear panel, disconnect BNC cable connected between INT and EXT Frequency Standard connectors, set INT/EXT switch to EXT, then connect cable from EXT connector to Spectrum Analyzer Frequency Reference (10 MHz) rear-panel connector. Allow one-half hour warm up time.

5-26. M/N LOOP, A32, A33, AND A32A1 (Cont'd)

2. Set LINE switch to ON and press [INSTR PRESET]. Connect jumper between A59TP4 DLI and A59TP5 +5V to disable the UNLK indicator circuit.
3. Disconnect cable from A33J2 M/N OUT and connect this output to Spectrum Analyzer RF INPUT. Set Spectrum Analyzer as follows:

CENTER FREQ.	197.419
REF LEVEL.....	3 dBm
ATTEN.....	+20 dB
LOG SCALE.....	1 dB/DIV
RES BW.....	300 Hz
VBW.....	300 Hz
FREQ SPAN.....	5 KHz
SWEEP TIME.....	1 SEC.
MARKER ENTRY.....	Press PEAK SEARCH
MARKER ENTRY.....	Press MKR→CF
MARKER MODE.....	Press SIGNAL TRACK

4. Press 8340A [CW] then enter [6] [0] [9] [0] [MHz].
5. The M/N output frequency indicated on Spectrum Analyzer should be 197.419 MHz ±1 count.

NOTE

To display the frequencies that the processor programs, press 8340A under Test [SHIFT][M1]. It will display from left to right: the M divide number, the N divide number, the M/N output frequency, and the 20/30 output frequency.

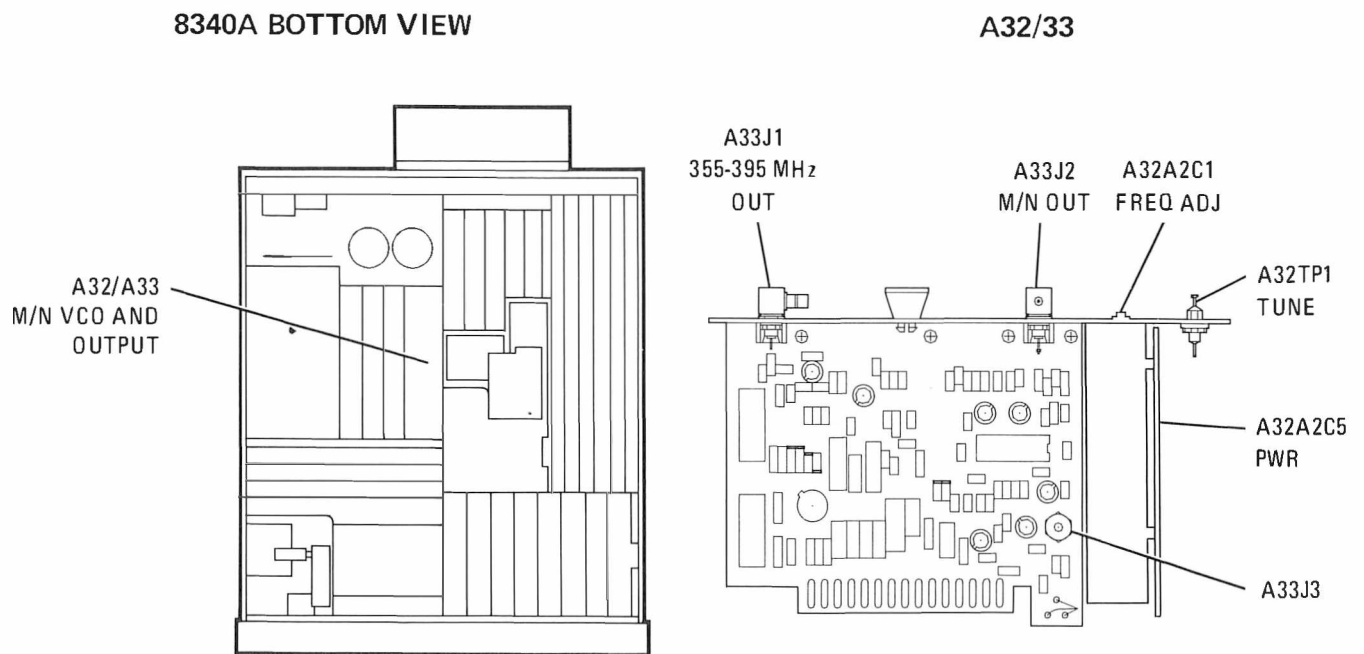

Figure 5-9. Location of M/N Loop Adjustments

5-26. M/N LOOP, A32, A33, AND A32A1 (Cont'd)

6. Connect DVM to A32TP1 TUNE test point. Refer to Figure 5-9 for location of A32 assembly.
7. Loosen locknut on A32A2C1 FREQ ADJ control and adjust A32A2C1 for DVM reading of $-35.0 \text{ Vdc} \pm 0.5 \text{ Vdc}$. Retighten A32A2C1 locknut. Verify that DVM reading is still within tolerance.
8. Press 8340A [**CW**] then enter [**2**] [**3**] [**0**] [**0**] [**MHz**].
9. Set Spectrum Analyzer for Center Frequency of 179.230 MHz. Frequency indicated on Spectrum Analyzer should be 179.230 MHz ± 1 count and the DVM should read $-2.8 \text{ Vdc} \pm 0.5 \text{ Vdc}$.
10. Set 8340A LINE switch to STANDBY.
11. Disconnect DVM from A32 assembly. Remove A32/A33 assembly from instrument and place on extender board.
12. Disconnect A32 output cable A32A1W1 from A33J3 (Figure 5-9) and connect this cable using SMB male-to-male adapter to the input of the Spectrum Analyzer. Set 8340A LINE switch to ON and press [**INSTR PRESET**] pushbutton.
13. Set Spectrum Analyzer Center Frequency to 375 MHz, Frequency Span to 10 MHz/Division, and Reference Level to +5 dBm.

CAUTION

Do not apply a positive voltage to A32TP1 or damage may occur to the VCO tuning diodes.

14. Connect the low-voltage power supply to the 8340A as follows: Positive lead to ground (do this first). Negative lead to A32TP1 TUNE test point. Set the output of the supply for $-35.0 \text{ Vdc} \pm 0.5 \text{ Vdc}$.
15. Adjust A32A2C5 PWR for a VCO output level of 0 dBm ± 2 dB as indicated on Spectrum Analyzer. Refer to Figure 5-9 for location of adjustment.
16. Slowly reduce the dc voltage output of the external low-voltage power supply connected to A32TP1 TUNE test point while monitoring the VCO output level on the Spectrum Analyzer and voltage level on DVM.
17. The VCO output level should be greater than -2 dBm between 395 MHz (-35 Vdc) and 355 MHz (-2.8 Vdc).
18. Repeat Steps 2 through 9 to check frequency accuracy.
19. Set 8340A LINE switch to STANDBY. Disconnect all test equipment from A32/A33 assembly. Reconnect cable A32A1W1 to A33J3.
20. Reinstall A32/A33 M/N Output Assembly in instrument and remove jumper from A59TP4 to A59TP5 (UNLK indicator disable).
21. Disconnect cable from 8340A rear-panel EXT FREQUENCY STANDARD, reconnect BNC cable between INT and EXT connectors, and set adjacent switch to INT.

5-27. 20/30 LOOP PHASE LOCK, A36, A38, A39, A40, AND A43

Reference:

Performance Test: Frequency Range and CW Mode Accuracy
 Service Section: 20/30 Loops

Description:

Phase Lock Loop 2 is adjusted by selecting a very narrow span width and adjusting A40 and A43 for proper voltages at designated test points. If PLL2 will not phase lock (UNLK indicator is lit and [SHIFT] [EXT] diagnostic indicates N2 is at fault), the A41 PLL2 Phase Detector must be disabled and a slightly different procedure used to initially set the A40 and A43 adjustments.

Phase Lock Loop 3 is adjusted for maximum multiplier output level at 160 MHz. The VCO is adjusted by setting up proper voltage levels at A39TP3.

Phase Lock Loop 1 40 kHz LPF is properly adjusted using a function generator and spectrum analyzer with an active probe. The response of PLL1 is adjusted for maximum rejection of signals between 160 and 166 MHz using a signal generator and spectrum analyzer.

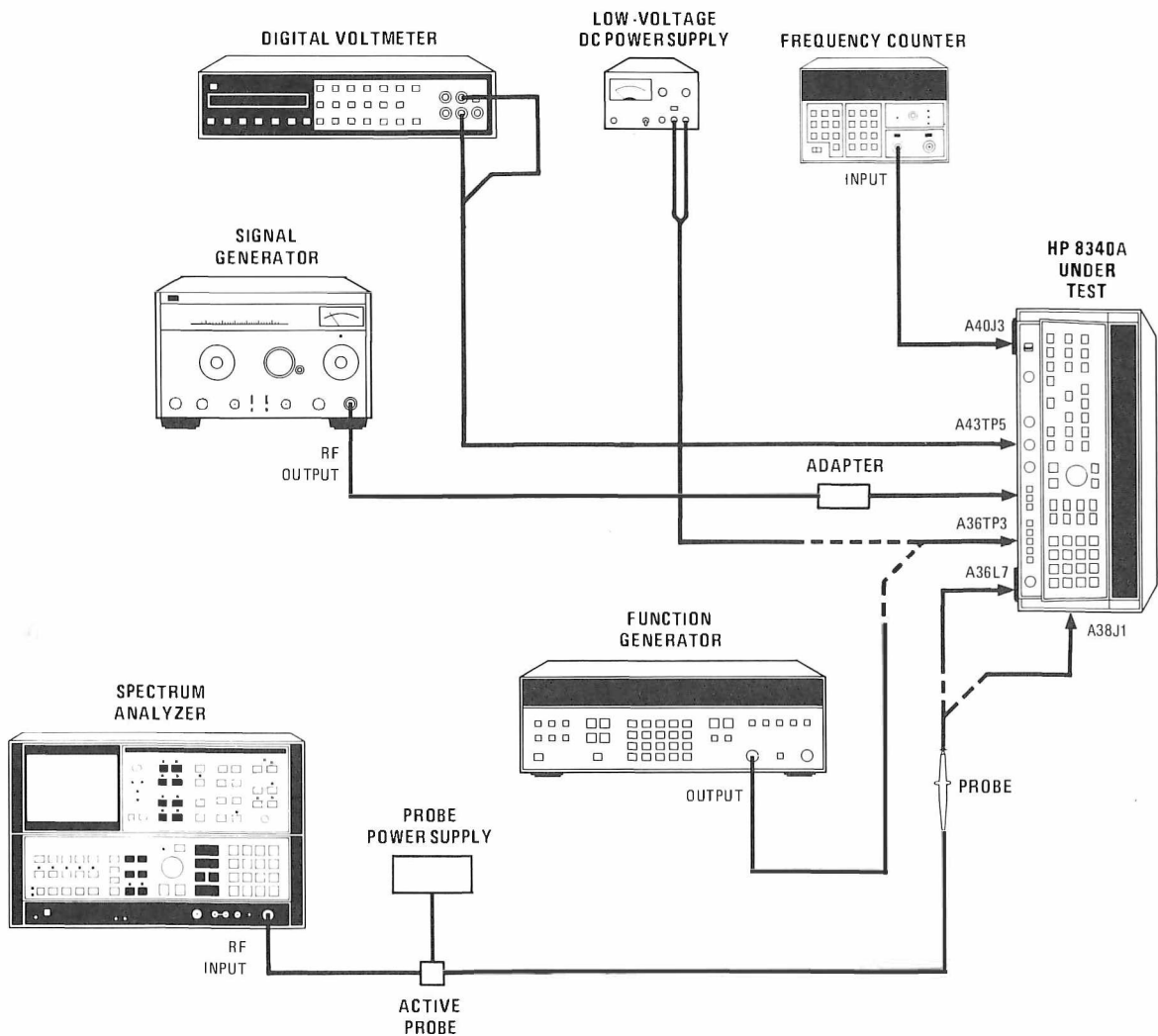

Figure 5-10. 20/30 Loop Phase Lock Adjustments Setup

5-27. 20/30 LOOP PHASE LOCK, A36, A38, A39, A40, AND A43 (Cont'd)**Equipment Required:**

Spectrum Analyzer.....	HP 8566A
Active Probe.....	HP 1121A
Probe Power Supply.....	HP 1122A
Signal Generator.....	HP 8654A
Low-Voltage DC Power Supply.....	HP 6294A
Digital Voltmeter (DVM).....	HP 3455A
Function Generator.....	HP 3325A
BNC to SMB Snap-On Test Cable.....	HP 85680-60093
Adapter, SMB Snap-On Male-to-Male.....	HP 1250-0069

Procedure:

PHASE LOCK LOOP 2

NOTE

If PLL2 is phase locked (UNLK annunciator not lit), proceed to step 12. If the UNLK annunciator is lit, determine if PLL2 (N2) is phase locked as follows: (a) Press [SHIFT] then [EXT], (b) Observe ENTRY display and if N2 is blinking, PLL2 is unlocked. With PLL2 unlocked, proceed to step 1. If some other oscillator circuit caused the UNLK indication, proceed to step 12.

1. Position 8340A in test position as shown in Figure 5-10 with bottom cover removed. Connect equipment as shown in Figure 5-10 and allow one-half hour warm up time. Set LINE switch to STANDBY. Remove A41 PLL2 Phase Detector from its connector on the motherboard. (It is not necessary to completely remove the A41 assembly from the instrument.)
2. Set LINE switch to ON and press [**INSTR PRESET**].
3. Remove cable from A40J3 .15–6MHz OUT FOR $\Delta F \leq .1$ MHz and connect Frequency Counter to A40J3 using BNC to SMB snap-on test cable.
4. Press [**CW**] then enter [**3**] [**0**] [**MHz**] to set the N2 oscillator to 150 MHz.
5. Connect DVM to A43TP5 VCO TUNE located on top cover of A43.
6. Adjust A40R2 150 MHz adjustment for a DVM indication of +3.0 Vdc ± 0.5 Vdc. Refer to Figure 5-11 for location of adjustments.
7. Adjust A43R9 .3 MHz adjustment for a Frequency Counter indication of 0.300 MHz ± 0.001 MHz (N2 frequency divided by 500).
8. Press [**CW**] then enter [**1**] [**9**] [**.**] [**9**] [**9**] [**9**] [**9**] [**9**] [**9**] [**MHz**] to set the N2 oscillator to 100 MHz.
9. Adjust A40R4 100 MHz adjustment for a DVM indication of +15.0 Vdc ± 0.5 Vdc.
10. Adjust A43R41 .2 MHz adjustment for a Frequency Counter indication of 0.200 MHz ± 0.001 MHz (N2 frequency divided by 500).

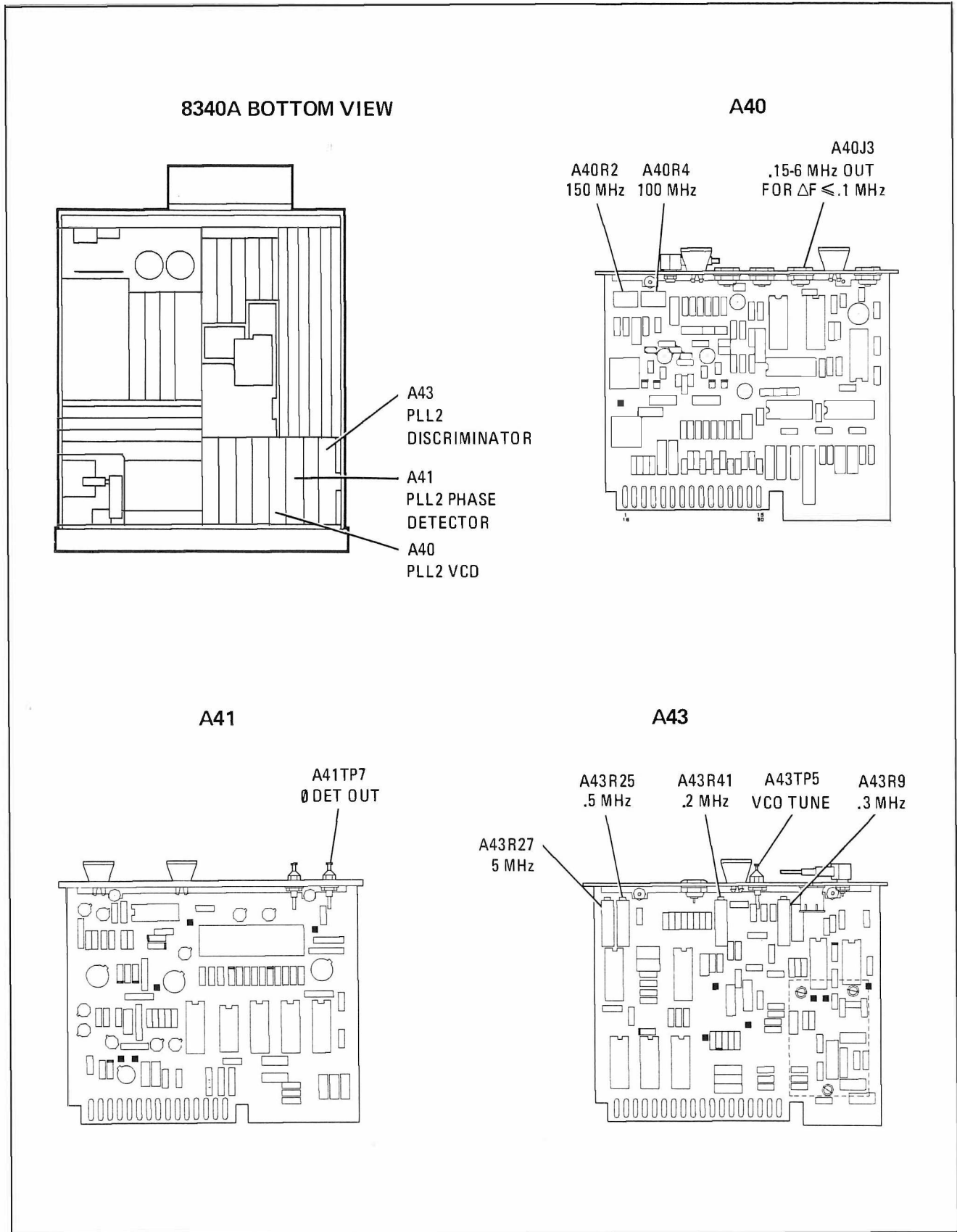

Figure 5-11. Location of PLL2 Adjustments

5-27. 20/30 LOOP PHASE LOCK, A36, A38, A39, A40, AND A43 (Cont'd)

11. Set LINE switch to STANDBY. Reinstall A41 PLL2 Phase Detector. Disconnect Frequency Counter from A40J3 and reconnect A39W1 cable to A40J3 (.15 – 6 MHz OUT FOR $\Delta F \leq .1$ MHz) connector.
12. Set LINE switch to ON. Press **[INSTR PRESET]**.
13. Press **[CW]** then enter **[3] [0] [MHz]** to set the N2 oscillator to 150 MHz.
14. Connect DVM to A43TP5 VCO TUNE located on top cover of A43.
15. Adjust A40R2 150 MHz adjustment for a DVM indication of +3.00 Vdc \pm 0.05 Vdc.
16. Connect DVM to A41TP7 ϕ DET OUT on top cover of A41.
17. Adjust A43R9 .3 MHz adjustment for a DVM indication of +3.50 Vdc \pm 0.05 Vdc.
18. Press **[CW]** then enter **[1] [9] [.] [9] [9] [9] [9] [9] [9] [MHz]** to set the N2 oscillator to 100 MHz.
19. Connect DVM to A43TP5 VCO TUNE located on top cover of A43.
20. Adjust A40R4 100 MHz adjustment for a DVM indication of +15.00 Vdc \pm 0.05 Vdc.
21. Connect DVM to A41TP7 ϕ DET OUT located on top cover of A41.
22. Adjust A43R41 .2 MHz adjustment for a DVM indication of 3.50 Vdc \pm 0.05 Vdc.
23. Repeat Steps 12 through 22 until no further adjustment is required.
24. Set 8566A Spectrum Analyzer as follows:
 - a. Press **[INSTR PRESET]**
 - b. Set CENTER FREQ to 29.5 MHz
 - c. Set SPAN to 200 kHz
25. Connect jumper between A59TP4 DL1 and A59TP5 + 5V to disable the UNLK indicator circuit.
26. Set HP 8340A as follows:
 - a. Press **[INSTR PRESET]**
 - b. Press **[START FREQ]** then enter **[2] [0] [MHz]**
 - c. Press **[STOP FREQ]** then enter **[2] [0] [.] [5] [MHz]**
 - d. Press **[SHIFT]**, then **[XTAL]** (This stops frequency at end of sweep without retrace).
 - e. Press **[SINGLE]** Sweep
27. Disconnect cable W39 from A36J1 OUT 20-30 MHz and connect Spectrum Analyzer RF INPUT to A36J1 through an SMB snap-on to BNC cable. Adjust A43R25 0.5 MHz ΔF to center the signal on the Spectrum Analyzer screen.

5-27. 20/30 LOOP PHASE LOCK, A36, A38, A39, A40, AND A43 (Cont'd)

28. Set 8566A Spectrum Analyzer as follows:
 - a. Set CENTER FREQ to 25 MHz
 - b. Set SPAN to 500 kHz
29. Set 8340A as follows:
 - a. Press **[INSTR PRESET]**
 - b. Press **[START FREQ]** then enter **[2] [0] [MHz]**
 - c. Press **[STOP FREQ]** then enter **[2] [5] [MHz]**
 - d. Press **[SHIFT]**, then **[XTAL]**
 - e. Press **[SINGLE]** Sweep
30. Adjust A43R27 5 MHz ΔF to center the signal on the Spectrum Analyzer screen.
31. Disconnect Spectrum Analyzer from A36J1 and reconnect W39 to A36J1 OUT 20–30 MHz.

PHASE LOCK LOOP 3

32. Set LINE switch to STANDBY. Remove A39 PLL3 Up Converter and install it on extender board.
33. Set LINE switch to ON. Press **[INSTR PRESET]**. Press **[CW]** then enter **[5] [GHz]**. Press **[SHIFT] [M3]** to display the PLL2 and PLL3 frequencies.
34. Connect Spectrum Analyzer to Test Connector A39J3 on P.C. board. Tune Spectrum Analyzer center frequency to 160 MHz. Set reference level to -20 dBm and set scale to 1 dB per division.
35. Adjust A39L16, A39L17, and A39C50 160 MHz PEAK for maximum signal level at 160 MHz. Iteration of L16 and L17 adjustment may be necessary. Refer to Figure 5-12 for location of adjustments.

If A39C50 does not have sufficient range, select the value of A39C49 for proper range. (Refer to Table 5-3.)

36. At the 8340A, select the following:
 - a. Press **[CF]** then enter **[6] [.] [6] [2] [7] [2] [5] [0] [GHz]**.
 - b. Press **[ΔF]** then enter **[1] [0] [0] [kHz]**.
 - c. Press **[SINGLE]** SWEEP.
37. Tune Spectrum Analyzer to a center frequency of 6 MHz. Set scale to 10 dB per division.
38. The 6 MHz signal displayed should be at least -42 dBm. If not, repeat Steps 33 through 37.
39. Connect DVM to A39TP3.
40. Adjust A39L11 PLL3 VCO ADJ for DVM indication of -7.0 Vdc ± 0.1 Vdc. The voltage may not change with initial adjustment but will change once the phase lock loop locks.

5-27. 20/30 LOOP PHASE LOCK, A36, A38, A39, A40, AND A43 (Cont'd)

41. Press 8340A [CF] then enter [5] [GHz]. Press [SINGLE] SWEEP pushbutton to initiate a sweep.
42. DVM indication should be $-3.0 \text{ Vdc} \pm 0.5 \text{ Vdc}$.
43. Set LINE switch to STANDBY. Disconnect test equipment and reinstall A39 PLL3 Up Converter in instrument.

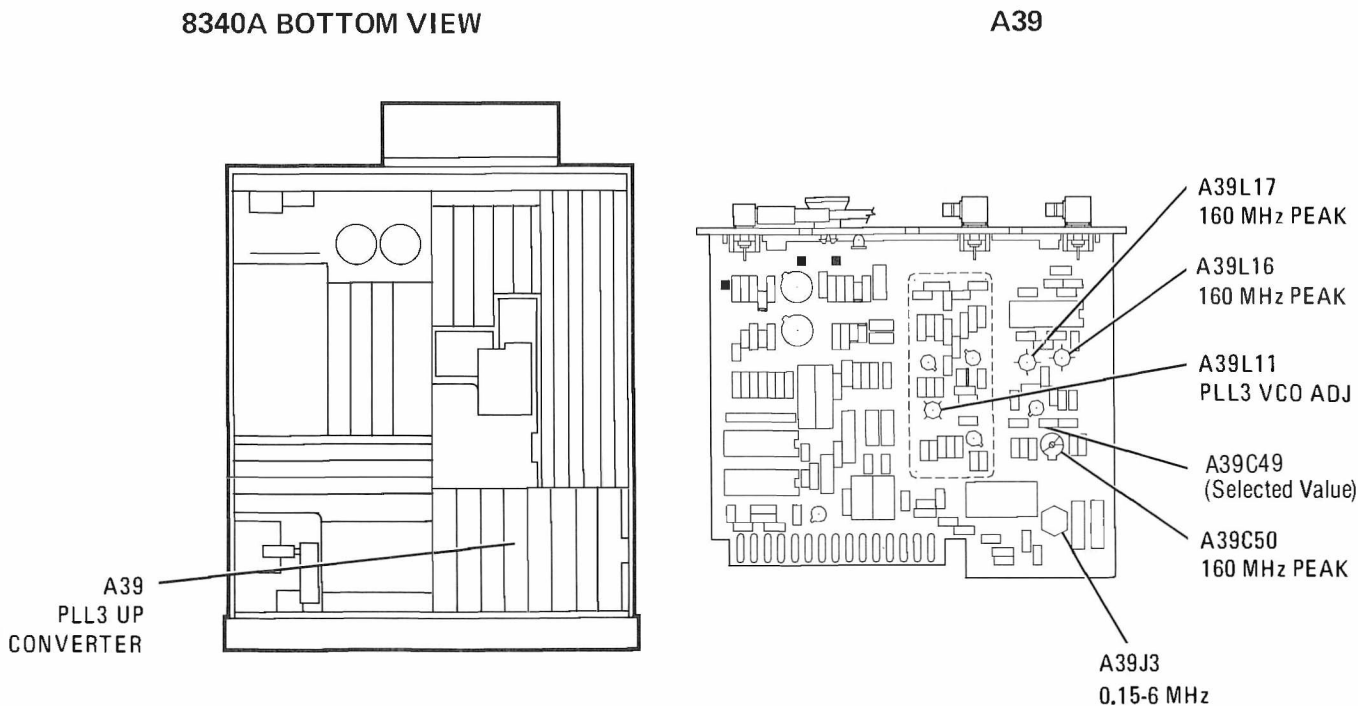

Figure 5-12. Location of PLL3 Adjustments

PHASE LOCK LOOP 1

44. Set LINE switch to STANDBY. Place A36 PLL1 VCO on an extender board. Remove all cables connected to A36.
45. Set Function Generator controls as follows:

FUNCTION	Sine Wave
FREQ	20 kHz
AMPL	-7.7 dBm

5-27. 20/30 LOOP PHASE LOCK, A36, A38, A39, A40, AND A43 (Cont'd)

46. Set Spectrum Analyzer controls as follows:

INSTR PRESET	Press
START FREQ.....	10 kHz
STOP FREQ.....	60 kHz
REFERENCE LINE.....	0 dBm
RES BW.....	300 Hz
VIDEO BW.....	1 kHz
SWEEP TIME.....	1.2 SEC
SCALE.....	10 dB/DIV
MARKER MODE.....	NORMAL

47. Set Spectrum Analyzer Marker to 20 kHz.
48. Connect active probe to Spectrum Analyzer input and connect probe to output of 40 kHz LPF on A36 (see Figure 5-13). (This is the terminal on A36L7 next to A36C24.)
49. Adjust Function Generator amplitude to place the 20 kHz signal displayed on the Spectrum Analyzer at the 0 dBm reference line.
50. Set Function Generator to 50 kHz.
51. Set Spectrum Analyzer Marker to 50 kHz.
52. Adjust A36L7 and A36L8 50 kHz NULL adjustments to null the 50 kHz signal displayed on the Spectrum Analyzer. Refer to Figure 5-13 for location of adjustments.
53. Note the level of the 50 kHz signal. This level should be at least 65 dB down from the level of the 20 kHz response. Disconnect test equipment from A36 assembly.
54. Disconnect active probe from Spectrum Analyzer and connect Spectrum Analyzer input to A36J2 OUT 200–300 MHz using a BNC to SMB snap-on test cable. Set LINE switch to ON.
55. Set Spectrum Analyzer as follows:

INSTR PRESET	Press
START FREQ.....	150 MHz
STOP FREQ.....	470 MHz
REF LINE.....	+10 dBm
MARKER.....	PEAK SEARCH

56. Connect an external low-voltage dc power supply positive lead to A36TP3 and the negative lead to any convenient chassis ground. Set external power supply for +16.0 Vdc \pm 0.1 Vdc.
57. Oscillator frequency should be 310 MHz \pm 10 MHz as indicated on the Spectrum Analyzer. If not, remove metal shield from A36 assembly and increase or decrease spacing between turns of A36L4 and increase or decrease the area of the single turn of A36L5 to properly tune the oscillator.
58. Change power supply voltage to +4.0 Vdc \pm 0.1 Vdc.

5-27. 20/30 LOOP PHASE LOCK, A36, A38, A39, A40, AND A43 (Cont'd)

- 59. Oscillator frequency should drop below 200 MHz with an amplitude greater than -7 dBm.
- 60. Repeat Steps 56 through 59 if necessary to meet requirements.
- 61. Set LINE switch to STANDBY. Reinstall metal shield on A36 if removed, reinstall A36 PLL1 VCO assembly in instrument, and reconnect all cables.
- 62. Remove A38 PLL1 IF assembly from instrument and install it on an extender board. Connect all cables to A38.
- 63. Set LINE switch to ON and press [INSTR PRESET]. Press [CW] then enter [1] [3] [.] [9] [7] [MHz].
- 64. Connect Spectrum Analyzer to A38J1 OUT PLL1 IF. Set Spectrum Analyzer controls as follows:

INSTR PRESET	Press
CENTER FREQ.....	170 MHz
FREQ SPAN.....	200 kHz
RES BW.....	3 kHz
VBW.....	3 kHz
SWP.....	100 ms
REF LEVEL.....	-10 dBm
ATT.....	0 dB
SCALE/DIV.....	10 dB/DIV
MARKER	NORMAL

- 65. Disconnect cable from A36J2 OUT 200–300 MHz and connect the cable to Signal Generator using BNC to SMB snap-on test cable and adapter.
- 66. Adjust A38L11 165 MHz NULL, A38L12 160 MHz NULL, and A38L13 170 MHz NULL fully clockwise.
- 67. Set Signal Generator for an output of $330.3 \text{ MHz} \pm 0.2 \text{ MHz}$ at 0 dBm.
- 68. Adjust A38L13 170 MHz NULL to null the 170 MHz signal on the Spectrum Analyzer.
- 69. Change Signal Generator frequency to $325.3 \text{ MHz} \pm 0.2 \text{ MHz}$. Set Spectrum Analyzer CENTER FREQ to 165 MHz.
- 70. Adjust A38L11 165 MHz NULL to null the 165 MHz signal on the Spectrum Analyzer.
- 71. Change Signal Generator frequency to $320.3 \text{ MHz} \pm 0.2 \text{ MHz}$. Set Spectrum Analyzer CENTER FREQ to 160 MHz.
- 72. Adjust A38L12 160 MHz NULL to null the 160 MHz signal on the Spectrum Analyzer.
- 73. Set the Spectrum Analyzer CENTER FREQ to 140 MHz. Tune the Signal Generator to $300.3 \text{ MHz} \pm 0.2 \text{ MHz}$. Note the amplitude of the 140 MHz response on the Spectrum Analyzer.

5-27. 20/30 LOOP PHASE LOCK, A36, A38, A39, A40, AND A43 (Cont'd)

74. Set the Spectrum Analyzer as follows:

INSTR PRESET	Press
START FREQ.	130 MHz
STOP FREQ.	170 MHz
MARKER	NORMAL
MARKER frequency	140 MHz

Slowly tune the Signal Generator from 320.3 to 326.3 MHz while monitoring the display on the Spectrum Analyzer.

75. The amplitude of the signal response between 160 and 166 (Signal Generator frequency of 320.3 to 326.3 MHz) should be at least 60 dB below the response at 140 MHz (Signal Generator frequency of 300.3 MHz) noted in Step 73.
76. Set LINE switch to STANDBY. Reinstall A38 PLL1 IF assembly in instrument and reconnect all cables.

5-28. YO PRETUNE DAC, A54

Reference:

Performance Test: None
 Service Section: Sweep Generator - YO Loop

Description:

This procedure makes gain and offset adjustments to the pretune voltage such that the lowest output voltage from the DAC will tune the YO to its lowest frequency (2.3 GHz), and the highest voltage out of the DAC (full scale) will tune the YO to its highest frequency (7 GHz).

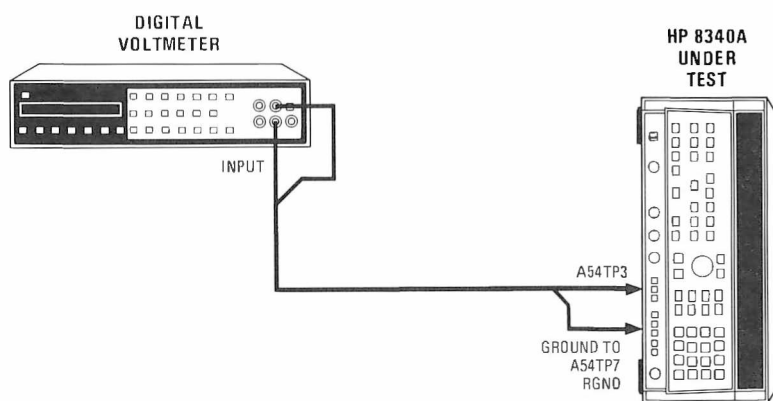

Figure 5-14. YO Pretune DAC Gain Test Setup

Equipment Required:

Digital Voltmeter (DVM) HP 3455A

Procedure:

1. Position the 8340A in the Test Position as shown in Figure 5-14 with bottom cover removed. Connect equipment as shown in Figure 5-14 and allow one-half hour warm up time. Be sure to connect DVM ground to A54TP7 REF. Ground.
2. Set the 8340A Under test as follows:
 - a. Press **[INSTR PRESET]**
 - b. Press **[CW]** then enter **[2] [.] [3] [GHz]** to tune the YO to 2.3 GHz (minimum DAC output).
3. Adjust A54R22 POFF control (Figure 5-15) for -5.75 ± 0.001 Vdc.
4. Press 8340A Under Test **[CW]** then enter **[6] [9] [9] [9] [.] [9] [9] [9] [9] [9] [MHz]** to set the YO close to 7 GHz (maximum DAC output).
5. Adjust A54R14 PGN control (Figure 5-15) for -17.5 ± 0.001 Vdc.

5-28. YO PRETUNE DAC, A54 (Cont'd)

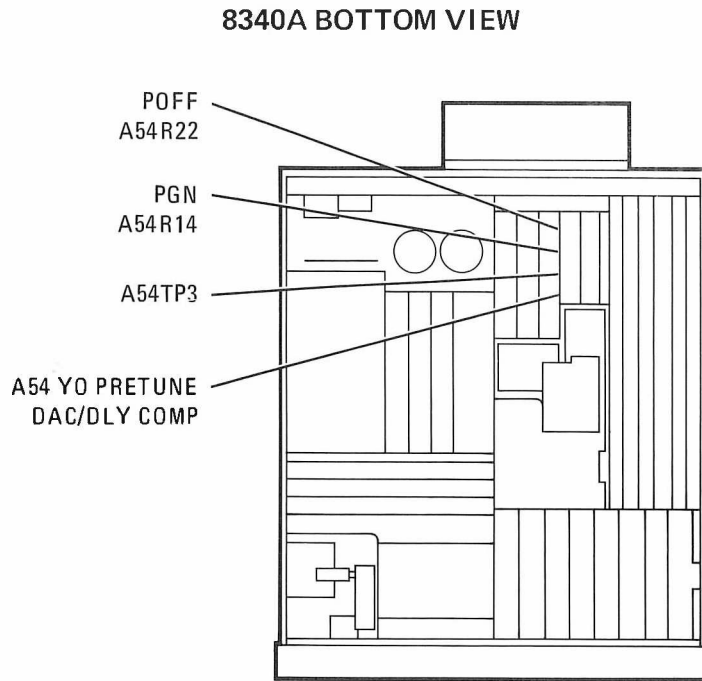

Figure 5-15. YO Pretune DAC Gain Adjustments Location

5-29. YO MAIN DRIVER, A55**Reference:**

Performance Test: None

Service Section: Sweep Generator – YO Loop

Description:

The FM coil in the YO is disabled. The Main Coil Driver circuit gain and offset are then adjusted for the correct output frequency.

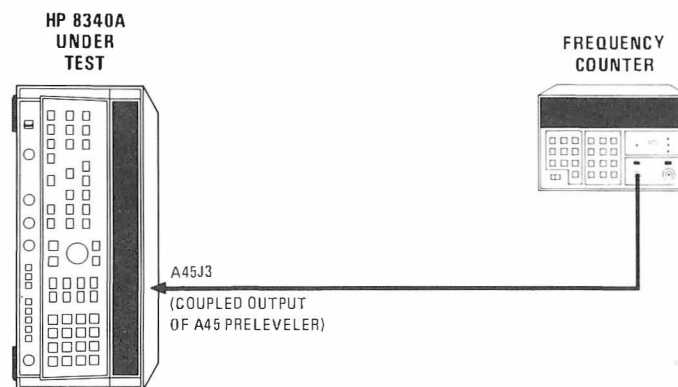

Figure 5-16. YO Main Driver A55 Test Setup

Equipment Required:

Frequency Counter..... HP 5343A

Procedure:

1. Position 8340A in the Test Position as shown in Figure 5-16 with bottom cover removed. Connect equipment as shown in Figure 5-16 and allow one-half hour warm up time.
2. Remove cable W38 from A49J2 and connect a 50 Ohm load to the end of the cable.
3. Set the 8340A Under Test as follows:
 - a. Press [**INSTR PRESET**]
 - b. Press [**CW**] then enter [**2**] [**.**] [**3**] [**GHz**].
4. Adjust A55R47 OFFSET (Figure 5-17) for an indication at the Frequency Counter of 2.3 GHz \pm 1 MHz.
5. Press 8340A [**CW**] then enter [**6**] [**.**] [**9**] [**9**] [**9**] [**GHz**].

5-29. YO MAIN DRIVER , A55 (Cont'd)

6. Adjust A55R4 GAIN (Figure 5-17) for an indication on the Frequency Counter of 6.999 GHz \pm 1 MHz.
7. Repeat steps 3 through 6 until no further adjustments are necessary.
8. Disconnect Frequency Counter and reconnect cable to A45J3 Preleveler Output. Remove 50 Ohm load from cable W37 and reconnect the cable to A49J2.

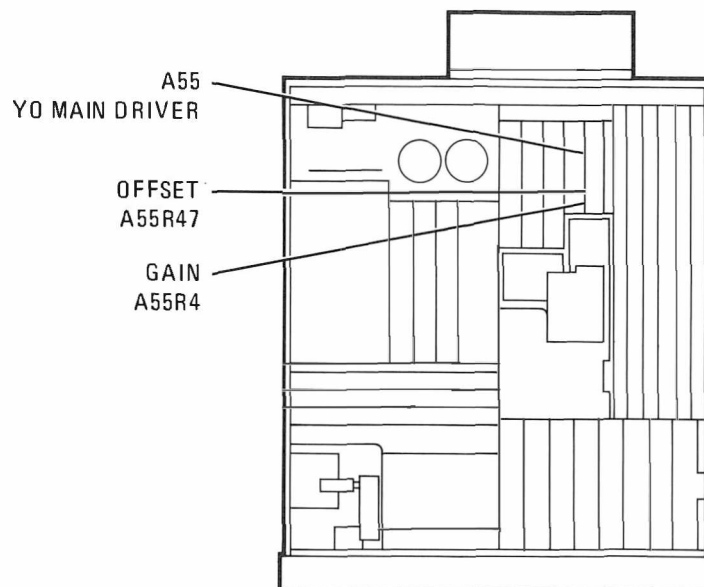
8340A BOTTOM VIEW*Figure 5-17. YO Main Driver A55 Adjustments Location*

5-30. YO LOOP ADJUSTMENTS

Reference:

Performance Test: None
 Service Section: Sweep Generator – YO Loop

Description:

This procedure adjusts the sampler drive circuitry and the IF gain.

NOTE

The YO frequency adjustment in Paragraph 5-29 must be completed before these adjustments are made.

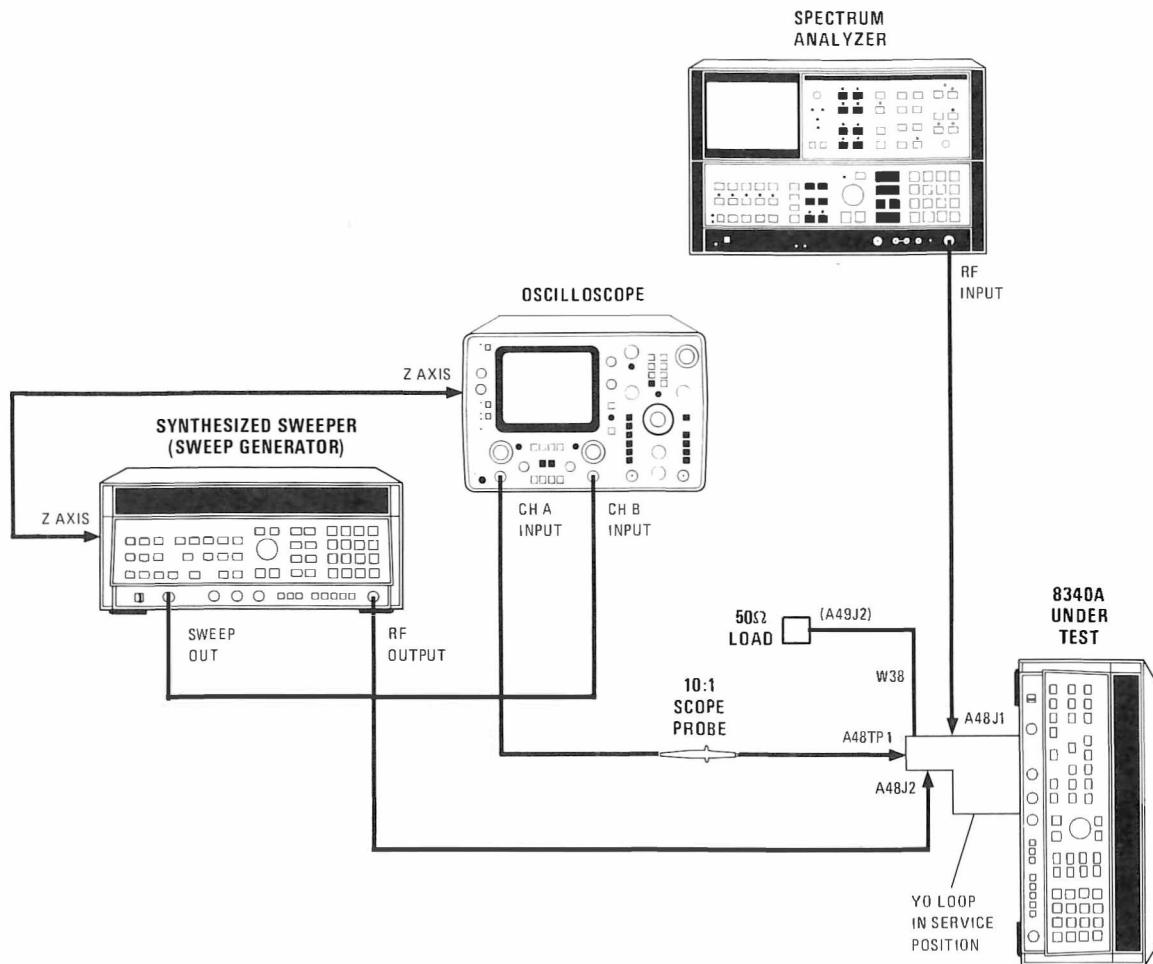

Figure 5-18. YO Loop Adjustment Setup

5-30. YO LOOP ADJUSTMENTS (Cont'd)**Equipment Required:**

Spectrum Analyzer.....	HP 8566A
Synthesized Sweeper	HP 8340A
Oscilloscope.....	HP 1741A
10:1 Divider Probe.....	HP 10004D
BNC to SMB Snap-On Test Cable (2 required)	85680-60093

Procedures:**YO LOOP RESPONSE ADJUSTMENT**

1. Put 8340A under test in the Test Position. Disconnect rigid cable going into A45 Preleveler RF Output through the mother board. Put the YO Loop section in the Service Position. Disconnect all cables that connect to A48 and A49 PC boards. Remove A48 YO Loop Sampler assembly cover. Connect a 50 Ohm load to W38 at the end that connects to A49J2.
2. Connect equipment as shown in Figure 5-18 except do not connect the Spectrum Analyzer. Set LINE to ON and allow 1/2 hour warmup.
3. Set the Sweep Generator 8340A as follows:
 - a. Press [**INSTR PRESET**]
 - b. Press [**CF**] (center frequency) then enter [**1**] [**8**] [**7**] [**MHz**]
 - c. Press [**ΔF**] then enter [**2**] [**0**] [**0**] [**MHz**]
 - d. Press [**POWER LEVEL**] then enter [**3**] [**dBm**]
 - e. Press [**SWEEP TIME**] then enter [**1**] [**0**] [**msec**].
4. At the oscilloscope, set the controls as follows:
 - a. Select A vs. B mode
 - b. Set Channel A to 0.05 VOLTS/DIV (with 10:1 Probe)
 - c. Set Channel B to 1 VOLT/DIV (typically)
 - d. Select DC coupled on both channels.
5. On the oscilloscope, adjust channel B VOLTS/DIV (used as horizontal gain in A vs. B mode) for a trace of 10 horizontal divisions on the screen. Adjust oscilloscope POSITION control to center display trace.
6. Press Sweep Generator 8340A [**M1**] and enter [**1**] [**6**] [**0**] [**MHz**]. Press [**M2**] and enter [**2**] [**1**] [**0**] [**MHz**].
7. Adjust A48C1 and A48C2 response adjustments (Figure 5-19) for a trace on the oscilloscope similar to Figure 5-20. Adjust for flattest response from 160 MHz to 210 MHz. The amplitude of the response should be at least 0.4 Volts peak-to-peak.

5-30. YO LOOP ADJUSTMENTS (Cont'd)

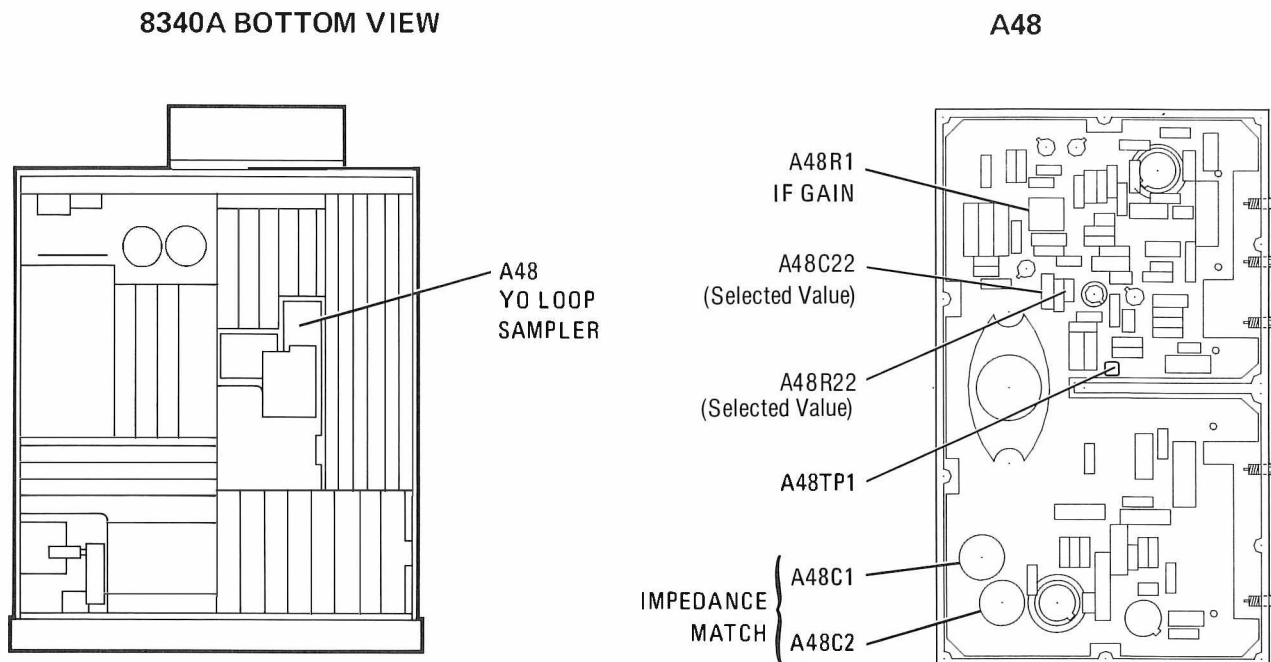

Figure 5-19. Location of YO Loop Adjustments

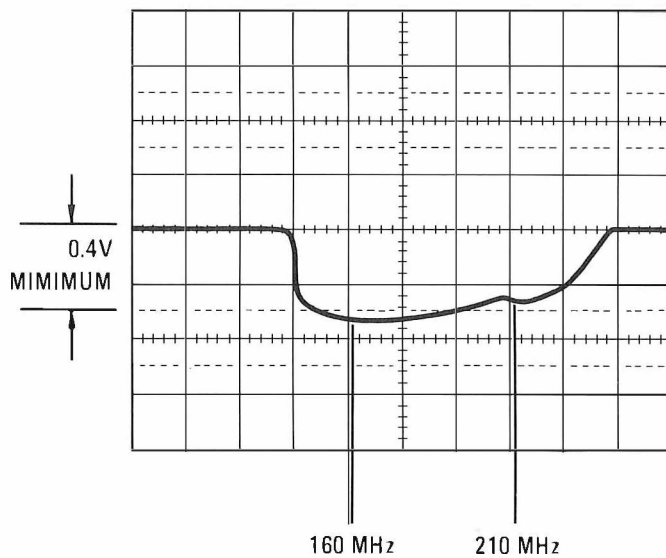

Figure 5-20. Typical Swept Frequency Response at A48TP1

5-30. YO LOOP ADJUSTMENTS (Cont'd)

IF GAIN ADJUSTMENT

8. Verify that the 50 Ohm load is still connected to W38 at the end that was connected to A49J2. Disconnect oscilloscope probe from A48TP1.
9. Connect the Spectrum Analyzer to A48J1.
10. Set the 8340A under Test as follows:
 - a. Press **[INSTR PRESET]**
 - b. Press **[CW]** then enter **[4] [.] [5] [GHz]**
 - c. Connect a jumper between A59TP4 and A59TP5. (This disables the UNLK annunciator circuit.)
11. Set the Sweep Generator 8340A as follows:
 - a. Press **[INSTR PRESET]**
 - b. Press **[POWER LEVEL]** then enter **[3] [dBm]**
 - c. Press **[CW]** then enter **[1] [8] [6] [MHz]**
 - d. Press **[SHIFT]** then **[CW]**; press **[STEP]** keys to select 1 kHz resolution.
12. On the Spectrum Analyzer, make the following settings:
 - a. Press **[INSTR PRESET]**
 - b. Set CENTER FREQ to 30 MHz
 - c. Set FREQUENCY SPAN to 60 MHz
 - d. Press Marker **[PEAK SEARCH]** then **[SIGNAL TRACK]**.
 - e. Set REF LEVEL to +10dBm.
13. Press Sweep Generator 8340A **[CW]** then adjust rotary knob to set a frequency that will produce a center frequency readout on the Spectrum Analyzer of 25.0 MHz. (See Figure 5-21.) Turn off **[SIGNAL TRACK]** on Spectrum Analyzer.
14. On the 8340A under test, adjust A48R1 IF GAIN control for a 25 MHz signal displayed on the Spectrum Analyzer of approximately 4 dBm.

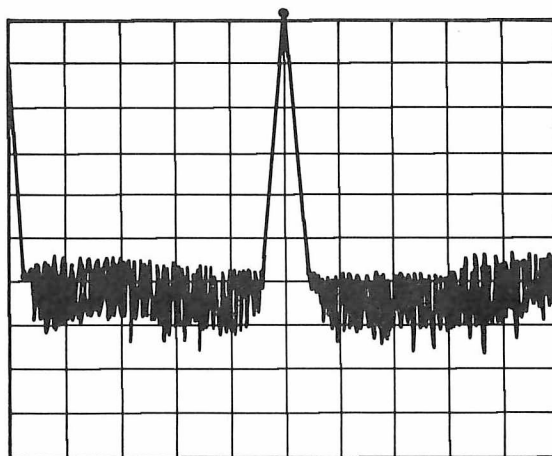

Figure 5-21. YO Loop Gain at A48J1

5-30. YO LOOP ADJUSTMENTS (Cont'd)

15. On the Spectrum Analyzer, make the following settings:
 - a. Press [**INSTR PRESET**]
 - b. Set **CENTER FREQUENCY** to 50 MHz
 - c. Set **FREQUENCY SPAN** to 100 MHz
 - d. Set **REFERENCE LEVEL** to +10 dBm
 - e. Select 5 dB/DIV
 - f. Select **MAX HOLD** on Trace B

NOTE

If Sweep Generator 8340A frequency is changed too quickly in Step 15, drop outs will occur on the Spectrum Analyzer display. If this happens, slowly adjust the Sweep Generator frequency so that the IF response passes over the drop outs and eliminates them.

16. Slowly tune the Sweep Generator 8340A using the rotary knob while monitoring the display on the Spectrum Analyzer. (Maximum hold may be used on the 8566A Spectrum Analyzer to trace out the IF response as frequency is changed.) Verify that the IF frequency response falls within the limits shown in Figure 5-22. If it does not, select new values for A48C22 and A48R22 to adjust the shape of the response (particularly in the 20 to 30 MHz region). Readjust A48R1 IF GAIN control if necessary.
17. Set 8340A under Test LINE to STANDBY. Disconnect all test cables going into 8340A under test.
18. Remove jumper between A59TP4 and A59TP5.
19. Reinstall A48 cover and reinstall YO Assembly into instrument; reconnect all cables.

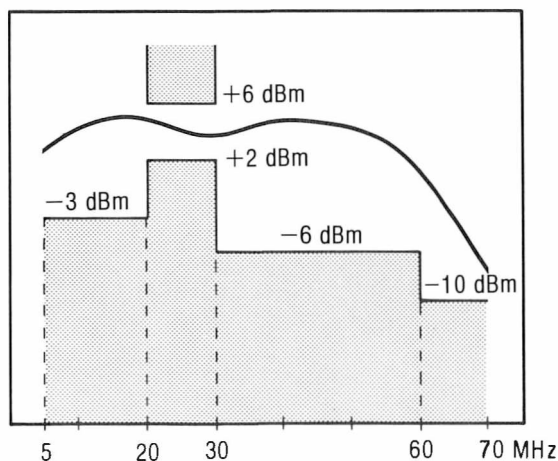

Figure 5-22. IF Frequency Response Limits

5-31. YO DELAY COMPENSATION, A54

Reference:

Performance Test: Swept Frequency Accuracy

Service Section: Sweep Generator - YO Loop

Description:

In this procedure, the programmable width of the YO kick pulse is calibrated. Then the YO delay is adjusted so the marker position tracks from the slowest to the fastest sweep speeds.

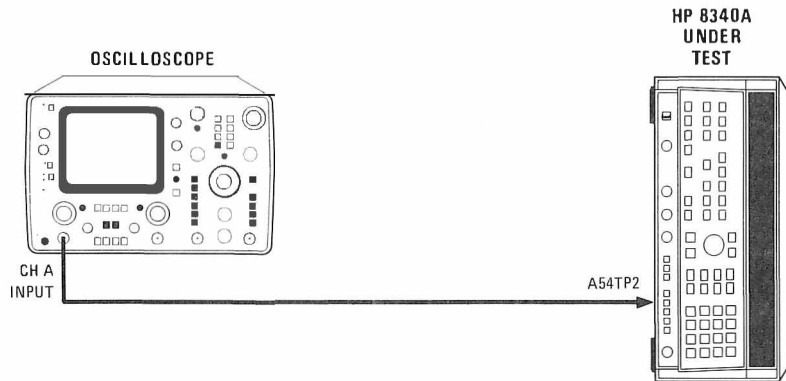

Figure 5-23. YO Kick Pulse Test Setup

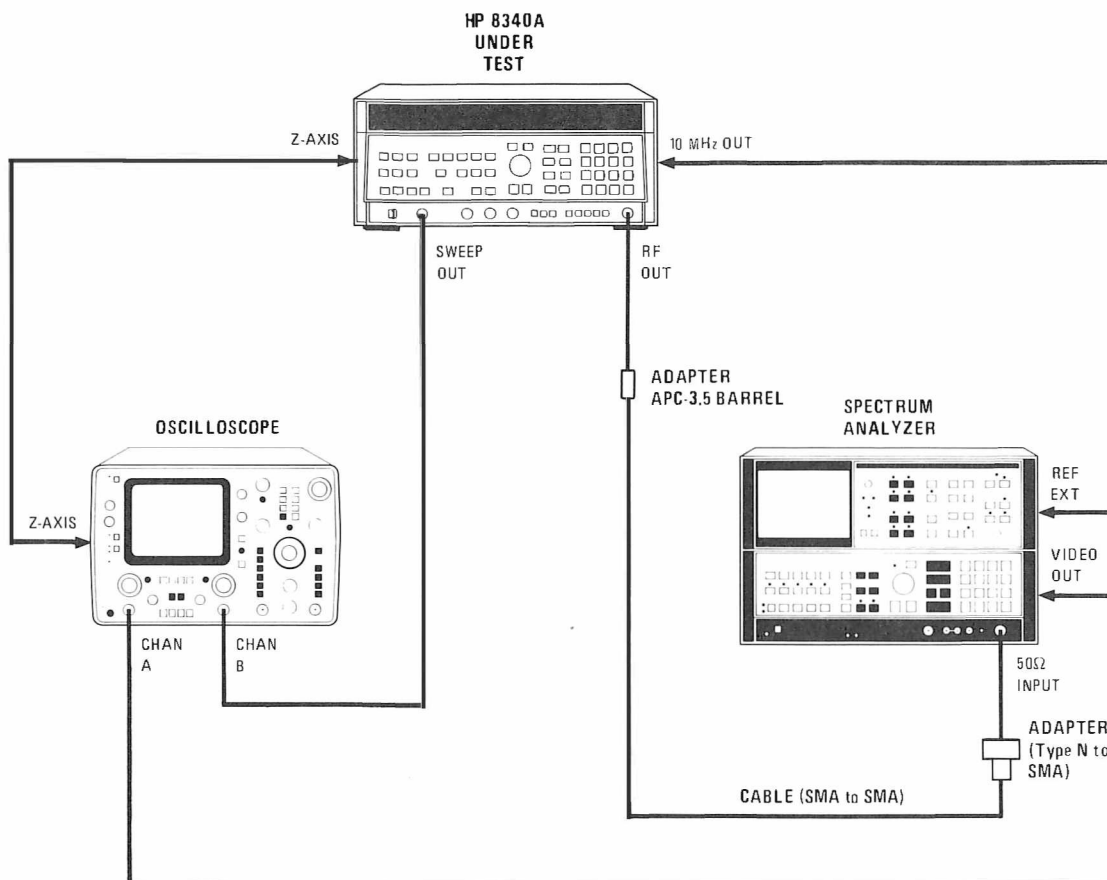

Figure 5-24. YO Delay Compensation Test Setup

5-31. YO DELAY COMPENSATION, A54 (Cont'd)

Equipment Required:

Spectrum Analyzer.....	HP 8566A
Oscilloscope.....	HP 1741A
Adapter, APC-3.5 female to female barrel.....	HP P/N 5061-5311
Cable, SMA male to SMA male.....	HP P/N 08340-20124

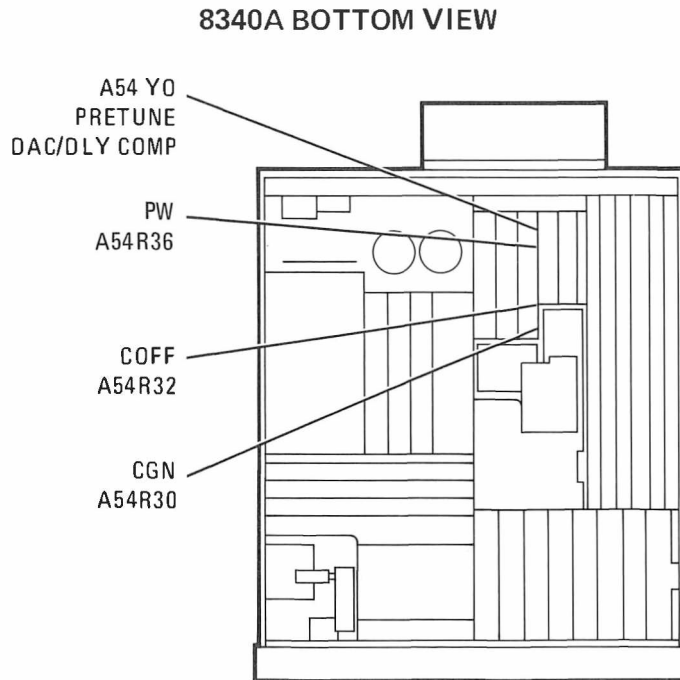

Figure 5-25. YO Delay Compensation Adjustments Location

Procedure:

1. Position the 8340A in the Test Position as shown in Figure 5-23 with bottom cover removed. Connect equipment as shown in Figure 5-23 and allow one-half hour warm up time.

YO KICK PULSE ADJUSTMENT

2. On the 8340A, make the following settings:
 - a. Press [**INSTR PRESET**]
 - b. Press [**START FREQ**] then enter [**2**] [**.**] [**3**] [**GHz**]
 - c. Press [**STOP FREQ**] then enter [**6**] [**.**] [**9**] [**9**] [**9**] [**GHz**].
3. Adjust A54R36 PW control (Figure 5-25) for a 12.5 msec pulse on the oscilloscope.

YO DELAY ADJUSTMENT

4. Connect equipment as shown in Figure 5-24.

5-31. YO DELAY COMPENSATION, A54 (Cont'd)

5. Set the 8340A Under Test as follows:
 - a. Press **[INSTR PRESET]**
 - b. Press **[START FREQ]** then enter **[6] [.] [9] [GHz]**
 - c. Press **[STOP FREQ]** then enter **[1] [3] [.] [5] [GHz]**
 - d. Press **[M1]** then enter **[7] [.] [2] [GHz]**
 - e. Press **[AMTD MKR]** on.
 - f. Press **[SAVE]** then enter **[2]**
 - g. Press **[SWEEP TIME]** then enter **[2] [0] [0] [msec]**
 - h. Press **[SAVE]** then enter **[1]**
 - i. Press Frequency Marker **[OFF]**
 - j. Press **[M2]** then enter **[1] [3] [.] [2] [GHz]**
 - k. Press **[SAVE]** then enter **[3]**
 - l. At ENTRY pad, press **[AUTO]** (sweep time)
 - m. Press **[SAVE]** then enter **[4]**
 - n. Press **[RECALL]** then enter **[1]**

6. At the Spectrum Analyzer, make the following settings:
 - a. Press **[INSTR PRESET]**
 - b. Press **[CENTER FREQUENCY]** then enter 7.2 GHz
 - c. Press **[FREQUENCY SPAN]** then enter 0 Hz
 - d. Press **[SINGLE]** Sweep

7. At the 1741A Oscilloscope, make the following settings:
 - a. Select A vs. B Mode
 - b. Set Channel A Volts/Division to 0.5 V/DIV
 - c. Set Channel B Volts/Division to 0.1 V/DIV

8. Press 8340A Under Test **[RF]** to turn RF power off.

9. On oscilloscope, position marker to center screen with horizontal position control. Press oscilloscope MAG X 10. Reposition the beginning of the marker at center line of screen with horizontal position control. (See Figure 5-26.)

10. Press 8340A **[RF]** to turn RF power on.

11. Press Spectrum Analyzer CENTER FREQUENCY key then use rotary knob to set Center Frequency so the peak of the blip is at the center line of the oscilloscope screen. (See Figure 5-27.)

12. Press 8340A **[RECALL]** then enter **[2]**. Press **[RF]** to turn RF power off.

13. Adjust oscilloscope horizontal position to place the beginning of the marker at the center line of the screen.

14. Press 8340A **[RF]** key to turn RF power on. Adjust A54R32 COFF to set the peak of the blip at the center line of the oscilloscope screen.

15. Press 8340A **[RECALL]** then enter **[3]**.

16. Press Spectrum Analyzer CENTER FREQUENCY then enter 13.2 GHz.

5-31. YO DELAY COMPENSATION, A54 (Cont'd)

17. Set oscilloscope Channel B Volts/Division switch to 2 V/DIV.
18. Press 8340A **[RF]** to turn RF power off.
19. Adjust the oscilloscope horizontal position control so the beginning of the marker is at the center line of the screen.
20. Press 8340A **[RF]** to turn RF power on.
21. Press Spectrum Analyzer CENTER FREQUENCY and adjust frequency using rotary knob so the peak of the blip is at the center line of the oscilloscope screen.
22. Press 8340A **[RECALL]** then enter **[4]**. Press **[RF]** to turn RF power off.
23. Adjust oscilloscope horizontal position to place beginning of the marker at the center line of the screen.
24. Press 8340A **[RF]** key to turn RF power on. Adjust A54R30 CGN to set the peak of the blip at the center line of the oscilloscope screen.
25. Press **[RECALL]**, then enter **[1]**. Repeat steps 7 through 24 until no further adjustment of A54R30 CGN and A54R32 COFF is necessary.
26. Disconnect all test equipment and reconnect cables.

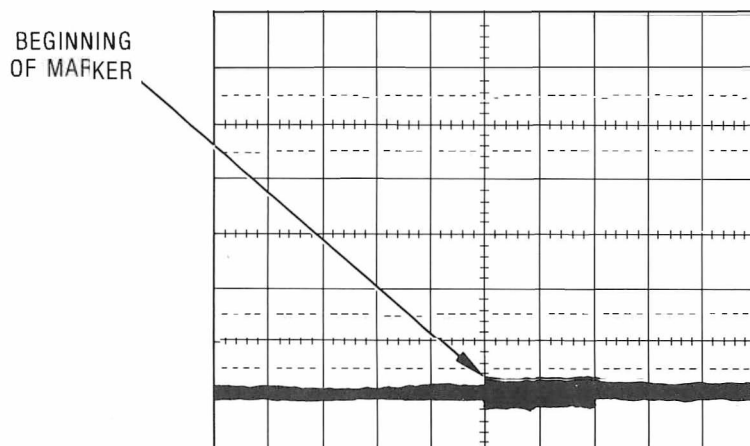

Figure 5-26. Z-Axis Marker Waveform

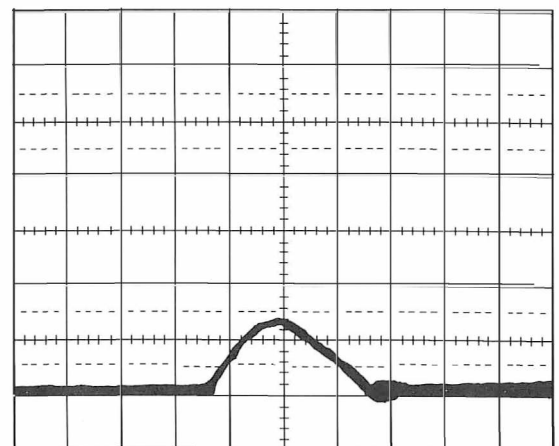

Figure 5-27. Amplitude Marker Waveform

5-32. 3.7 GHz OSCILLATOR, A8

NOTE

This procedure is provided primarily for those cases when the A8A1 circuit board has been repaired or replaced.

Reference:

Performance Test: None

Service Section: RF Section (Power Level Control)

Description:

This procedure monitors the output current of the 100 MHz RF Amplifier that provides the LO signal for the sampler and adjusts for maximum output. The oscillator phase-lock loop is then opened by removing jumper A8E3 and the balance is adjusted at the output of the sampler to obtain a symmetrical square wave of approximately 35 Volts peak-to-peak to drive the phase-lock amplifier.

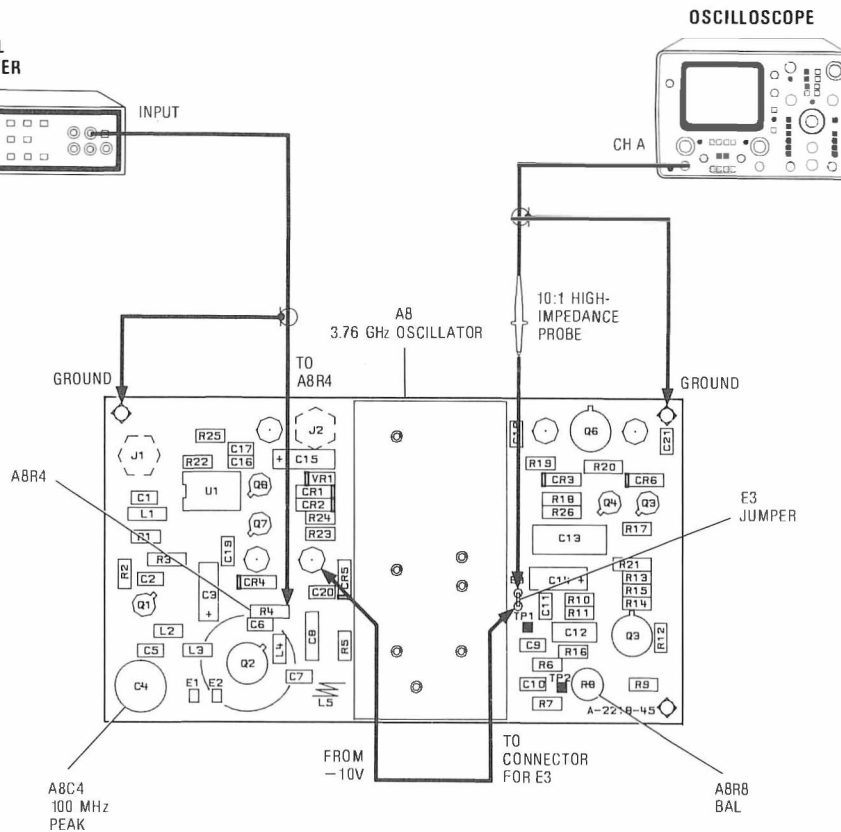

NOTE

ONLY MAKE TEST EQUIPMENT CONNECTIONS AS DIRECTED IN THE PROCEDURE.

Figure 5-28. A8 3.7 GHz Oscillator Test Setup

5-32. 3.7 GHz OSCILLATOR, A8 (Cont'd)

Equipment Required

Digital Voltmeter	HP 3455A
Oscilloscope	HP 1741A
10:1 Divider Probe	HP 10004D

Procedure

1. Connect DVM to A8R4 as shown in Figure 5-28.
2. Adjust A8C4 100 MHz Peak for minimum indication on DVM. (This is maximum current through A8R4 and A8Q2.)
3. Turn off HP 8340A and remove DVM connections from A8R4.
4. Remove jumper A8E3. Connect a jumper from the -10 Volt terminal to the lower connection point for E3 as shown in Figure 5-28. (This applies -10 Volts to the Oscillator.)
5. Connect the Oscilloscope 10:1 high-impedanced probe to the upper connection point for E3 as shown in Figure 5-28.
6. Adjust A8R8 BAL control for a 50% duty cycle square wave with approximately 35 Volts peak-to-peak signal.
7. Turn off 8340A, remove the -10 Volt jumper and oscilloscope probe connections, and reinstall jumper A8E3 in its original position.

5-33. MARKER/BANDCROSS, A57**Reference:**

Performance Test: None
Service Section: Controller

Description:

This procedure adjusts the manual sweep for a range of 0 to 10 Volts and sets the end of sweep at 10 Volts.

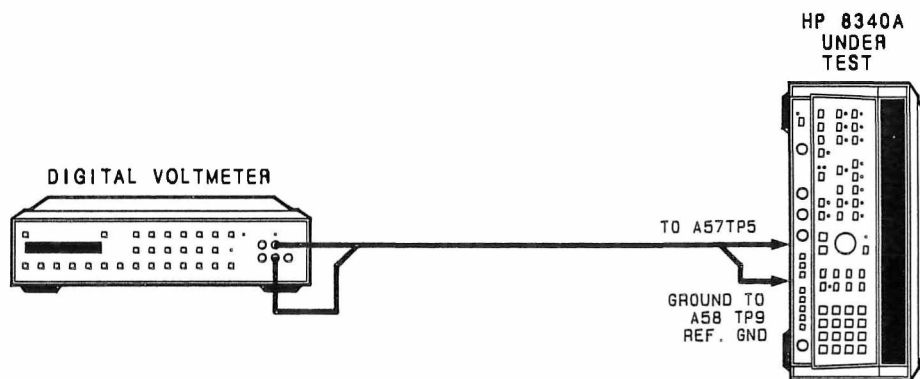

Figure 5-29. Marker Band Crossing Test Setup

Equipment Required:

Digital Voltmeter HP 3455A

Procedure:**MANUAL SWEEP GAIN**

1. Position the HP 8340A in the Test Position and connect equipment as shown in Figure 5-29. Allow one-half hour for warmup.
2. Set the HP 8340A Under Test as follows:
 - a. Press [INSTR PRESET]
 - b. Press [START] then enter [4] [GHz]
 - c. Press [STOP] then enter [5] [GHz]
 - d. Press [MANUAL] Sweep
 - e. Press [SHIFT] [GHz] then enter [1] [3] [Hz], [SHIFT] [MHz] then enter [2] [Hz], and [SHIFT] [kHz] then enter [1] [0] [0] [0] [Hz]. (This writes decimal 1,000 to IO address 13, R2.)
3. Adjust A57R33 MAN GAIN control (Figure 5-29) for 10.0000 ± 0.0005 Vdc at A57TP5 as indicated on DVM.

5-33. MARKER/BANDCROSS, A57 (Cont'd)

END OF SWEEP ADJUSTMENT

4. Set the 8340A Under Test as follows:
 - a. Press [**INSTR PRESET**]
 - b. Press [**START FREQ**] then enter [**4**] [**GHz**]
 - c. Press [**STOP FREQ**] then enter [**5**] [**GHz**]
 - d. Press [**SHIFT**] then [**XTAL**] to stop the sweep at the end of band (5 GHz).
5. Connect DVM to A57TP5 SWEEP OUT.
6. Adjust A57R32 EOS control (Figure 5-30) for an indication on the DVM of 10.000 ± 0.0008 Vdc.
7. Press [**CONT**] Sweep key after each adjustment is made for an update of end of sweep indication.
8. Repeat steps 6 and 7 until no further adjustment is needed.

8340A BOTTOM VIEW

Figure 5-30. Marker Band Crossing Adjustments Location

5-34. SWEEP GENERATOR, A58**Reference:**

Performance Test: Swept Frequency Accuracy

Service Section: Sweep Generator - YO Loop

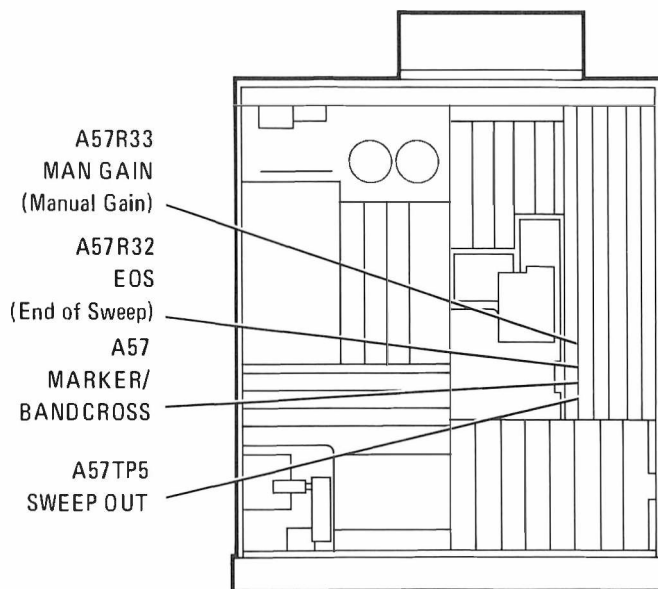
Description:

The first section adjusts the gain of the sweep ramp amplifier. The next section adjusts the reset error. The last section adjusts the relationship between the VSWP ramp signal and the marker ramp.

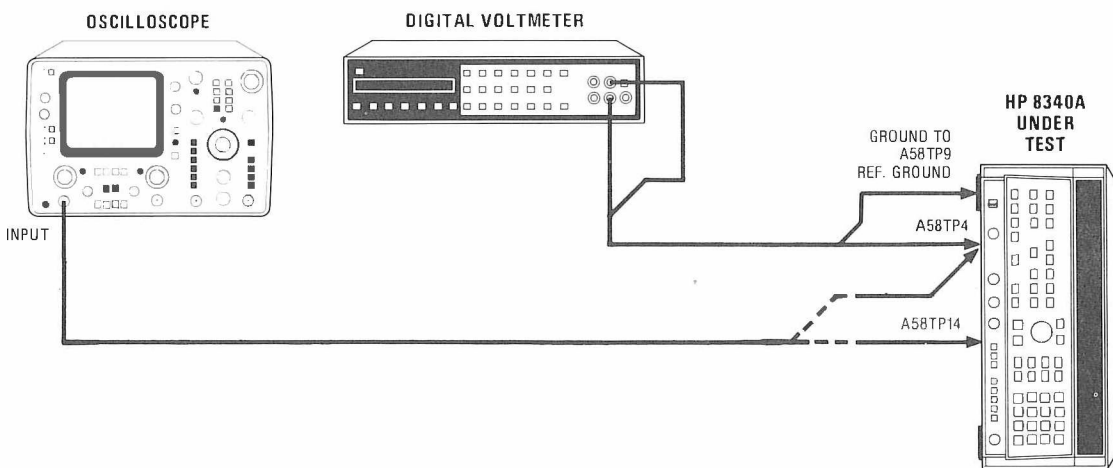

Figure 5-31. Sweep Generator Test Setup

Equipment Required:

Oscilloscope	HP 1741A
Digital Voltmeter (DVM)	HP 3455A

Procedure:

1. Position the 8340A in the Test Position as shown in Figure 5-31 with bottom cover removed. Connect oscilloscope to A58TP4. Allow one-half hour warm up time.

SWEEP RAMP GAIN ADJUSTMENT

2. Press 8340A [**INSTR PRESET**] then [**START FREQ**]. Enter [**2**] [,] [**3**] [**GHz**].
3. Press 8340A [**STOP FREQ**] then enter [**7**] [**GHz**].
4. Press [**SWEEP TIME**] then enter [**1**] [**0**] [**msec**].
5. Adjust A58R4 SWP TIME control (Figure 5-32) for a 10 mSec ramp on oscilloscope (Figure 5-33).

5-34. SWEEP GENERATOR, A58 (Cont'd)

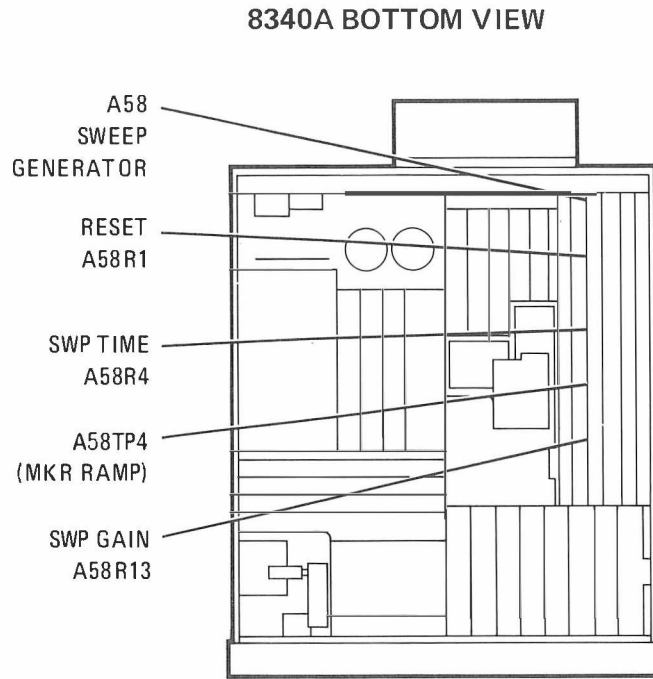

Figure 5-32. Sweep Generator Adjustments Location

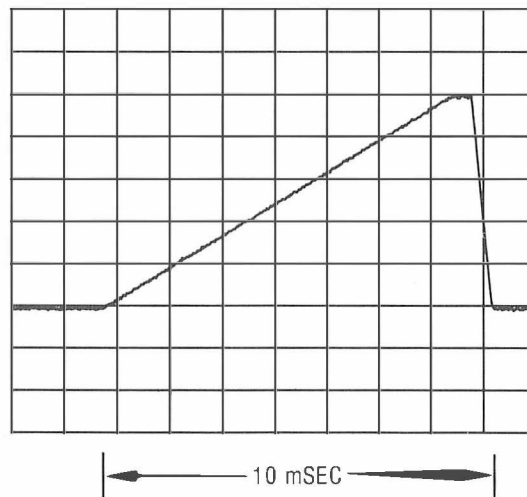

Figure 5-33. Sweep Ramp at A58TP4
SERIAL PREFIX: 2406A

5-34. SWEEP GENERATOR, A58 (Cont'd)**RESET ERROR ADJUSTMENT**

6. Connect oscilloscope to A58TP14.
7. Press 8340A [**INSTR PRESET**].
8. Adjust A58R1 RESET control (Figure 5-32) for as close as possible to zero Volt average on the oscilloscope. (See Figure 5-34.)

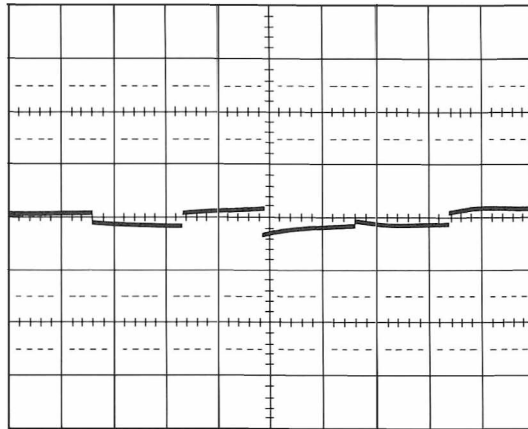

Figure 5-34. Reset Pulse Adjusted to Zero Volt Average

SWEEP GAIN ADJUSTMENT

9. Connect DVM to A58TP4 MKR RMP and connect DVM ground to A58TP9 REF. Ground.
10. Set the 8340A controls as follows:
 - a. Press [**INSTR PRESET**]
 - b. Press [**START FREQ**] then enter [**2**] [**.**] [**3**] [**GHz**]
 - c. Press [**STOP FREQ**] then enter [**7**] [**GHz**]
 - d. Press [**SHIFT**] then [**XTAL**] to stop the sweep at the end of sweep (7 GHz).
11. Record reading at DVM.
12. Connect DVM to A58TP10 VSWP.
13. Adjust A58R13 SWP GAIN control so that the DVM reading at A58TP10 = 94% of Reading at A58TP4 taken in step 11.
EXAMPLE:
 - a. DVM reading in step 11 at A58TP4 = 9.9884 Volts
 - b. $(0.94)(9.9884\text{V}) = 9.38909$ Volts
 - c. Adjust A58R13 for DVM reading at A58TP10 of 9.38909 Volts.

5-35. UNLEVELED RF OUTPUT ADJUSTMENTS**NOTE**

If equipment and the program are available to do the automated Unleveled Power Test and Adjustment described in manual supplement titled "Automated Test Procedures," it should be used instead of these procedures in Paragraph 5-35.

Reference:

Performance Test: Maximum Leveled Output Power and Accuracy

Service Section: RF Section

Description:

The A28 SYTM Driver Assembly is adjusted to cause the SYTM frequency response to track the YO frequency. When the YO frequency is in the center of the SYTM passband, the power loss through the SYTM is minimum; therefore, SYTM tracking is adjusted while viewing power out versus frequency and adjusting the SYTM tracking for maximum power out. The SRD bias is also adjusted for maximum power out. Since either adjustment may cause squegging (a power drop-out at the peak of the bandpass caused by an undesired oscillation of the SYTM's bias circuit), the tracking and SRD bias adjustments are made at the same time.

Sometimes you cannot tell by just the unleveled trace that the instrument is squegging. Sometimes, as the SRD bias is adjusted, the unleveled power will start to rise and then it will fall off. When it starts to fall off, it is an indication of possible squegging (usually in Band 2).

In Bands 2, 3, and 4, squegging occurs in the SRD diode circuit and is a function of SRD bias, power output, and tracking. In Band 1, squegging occurs in the SYTM YIG sphere and is a function of input power to SYTM.

Kick pulses are generated at retrace for the SYTM. These kick pulses are used so that the magnetics of the SYTM will always start from the same condition. The pulses have the effect of temporarily tuning the SYTM above the stop frequency and then below the start frequency. Since the kick pulses also affect delay, the kick pulse amplitudes are adjusted in this procedure.

NOTE

The following adjustments should be checked or adjusted before making the adjustments in this procedure: Power Supplies, 20/30 Loop, M/N Loop, Pretune, YO Loop, and Sweep Time.

5-35. UNLEVELED OUTPUT ADJUSTMENTS (Cont'd)

HO2 NOTE

THIS PAGE DOES NOT APPLY TO INSTRUMENTS EQUIPPED WITH OPTION HO2.

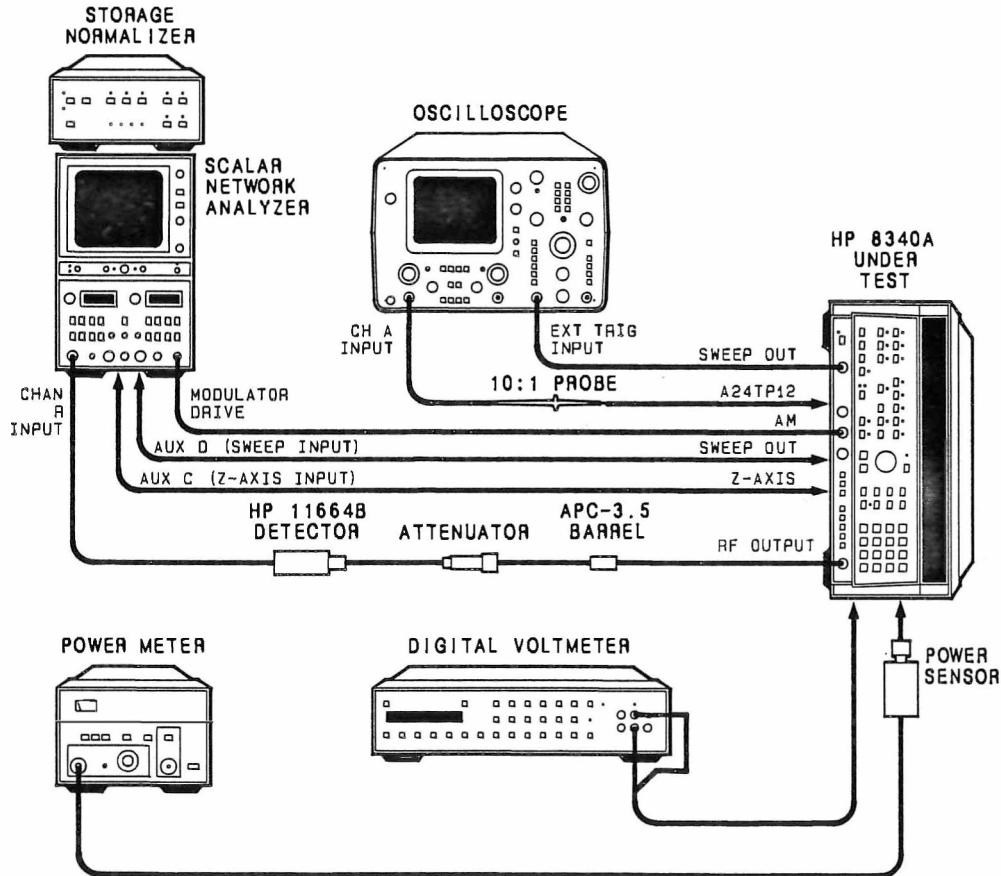

Figure 5-35. SYTM Tracking and Delay, and Unleveled SRD Bias Adjustment Test Setup

Equipment Required:

Frequency Response Test Set	HP 8755C
Detector	HP 11664B
Storage Normalizer	HP 8750A
Oscilloscope	HP 1741A
10:1 Divider Probe	HP 10004D
Digital Voltmeter	HP 3455A
Power Meter	HP 436A
Power Sensor	HP 8485A
10 dB Attenuator	HP 8493C Option 010

5-35. UNLEVELED RF OUTPUT ADJUSTMENTS (Cont'd)**HO2 NOTE**

THIS PAGE DOES NOT APPLY TO INSTRUMENTS EQUIPPED WITH OPTION HO2.

Procedure:

1. Place the 8340A in the Test Position and connect equipment as shown in Figure 5-35. Connect Digital Voltmeter (DVM) to 8340A rear-panel 1 V/GHz output connector. Allow one-half hour warmup time.
2. Press 8340A [CW] then enter [1] [0] [MHz].
3. Adjust A28R85 +10 ADM control for an indication on the DVM of 10 mV \pm 1 mV.

INITIAL SETTINGS**NOTE**

Once these initial settings have been made it will be necessary to complete this procedure and the SRD Bias adjustments.

If the A24 Assembly or the SYTM has been replaced, set A24R5 X2C, A24R8 X3C, and A24R11 X4C controls fully counterclockwise and center A24R12 MIN control.

4. Set A24R1 (OFF A) (Figure 5-36) and A24R2 (OFF B) controls fully clockwise.
5. Set A26R88 (MO) fully clockwise.
6. The A26 Assembly contains an ALC Loop gain control for each band. These controls may not require adjustment at this point; however, if the A26 Assembly has been replaced, these controls should be centered initially to ensure that a reasonable power level is obtained before making SYTM tracking adjustments. Center loop gain controls HET, X1, X2, X3, and X4 on the A26 Linear Modulator board **only if the ALC circuits require adjustment.**

SYTM TRACKING AND UNLEVELED SRD BIAS ADJUSTMENTS

7. Connect oscilloscope 10:1 probe to SRD BIAS test point, A24TP12. Press 8340A [INSTR PRESET]. Power level should be 0 dBm. Press [START FREQ] and enter [6] [.] [9] [GHz]. Press [STOP FREQ] and enter [1] [3] [.] [5] [GHz]. Press [SWEEP TIME] and enter [2] [0] [0] [msec]. Press [XTAL] leveling key to obtain non-leveled operation. The 8755C Modulation output must be connected to the 8340A AM INPUT. Press [SHIFT] [PULSE] keys.

The 8755A display of output power versus frequency should be similar to Figure 5-37 and the oscilloscope SRD bias display should be similar to Figure 5-38.

Turning the X2A/B, X3A/B, or X4A/B controls clockwise when in the appropriate band will increase the SRD bias and be closer to the squegging region. If squegging occurs, turn the above controls CCW.

THIS PAGE SUPERSEDES MANUAL CHANGE SUPPLEMENT PAGE C-82, IN CHANGE 3

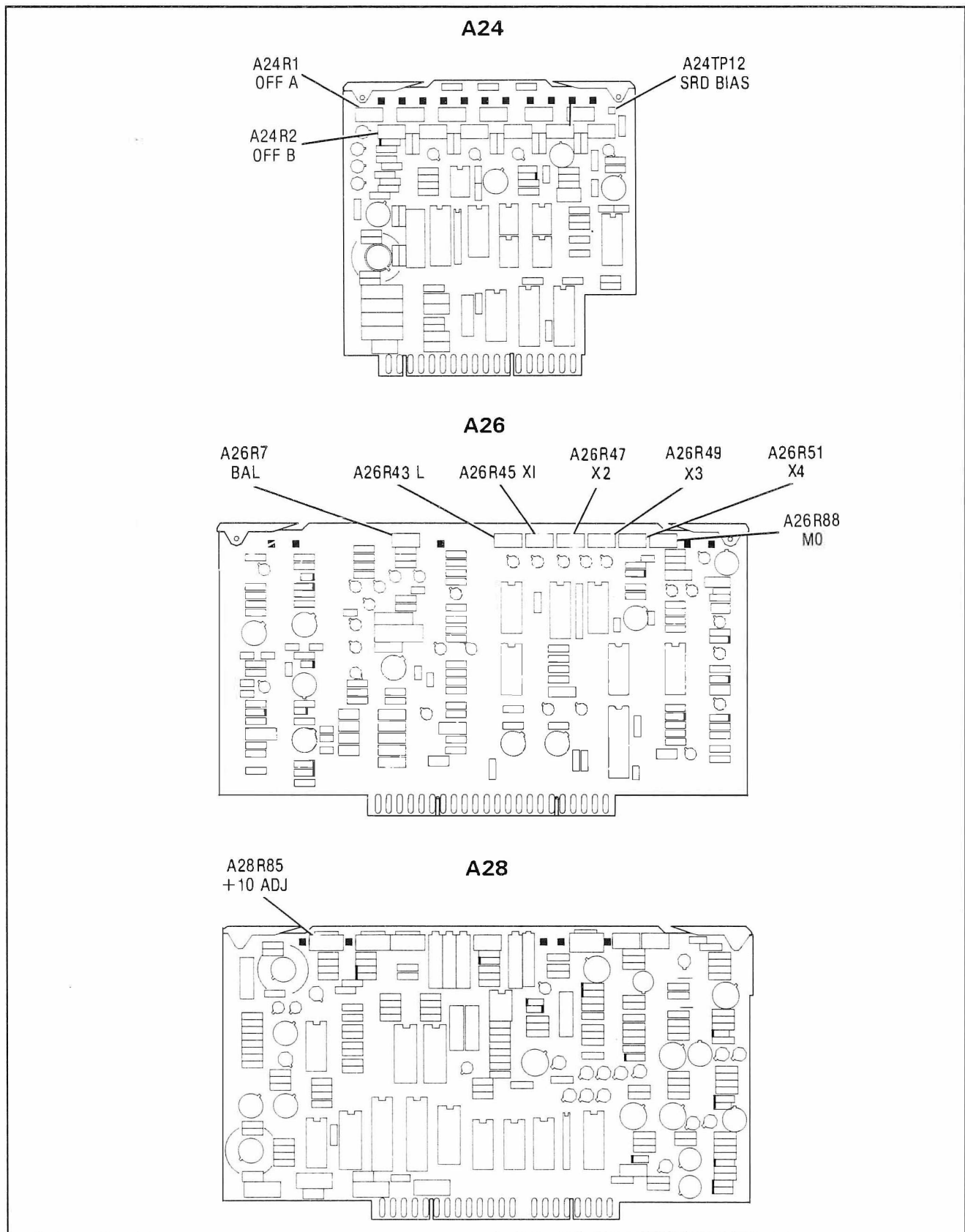
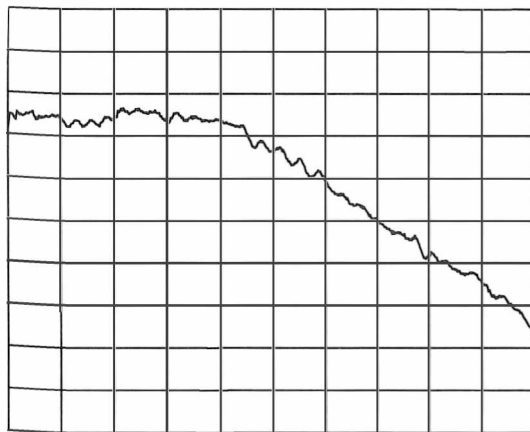

Figure 5-36. SRD Bias Adjustments Locations
ALL SERIALS

5-35. UNLEVELED RF OUTPUT ADJUSTMENTS (Cont'd)

NOTE

If the oscilloscope trace is flat or slopes down, the following adjustments will be more difficult to optimize. Therefore, adjust A24R3 (X2A) and A24R4 (X2B) in Band 2 only for maximum output power, but also for a slight upward slope with no squegging (a power drop-out at the peak of the bandpass caused by an undesired oscillation of the SYTM bias circuit). A slight adjustment of either control (X2A or X2B) will affect the slope considerably and should have little effect on the output power. Detailed instructions for these adjustments are given in the following steps.



WAVEFORM A
(NO SQUEGGING)

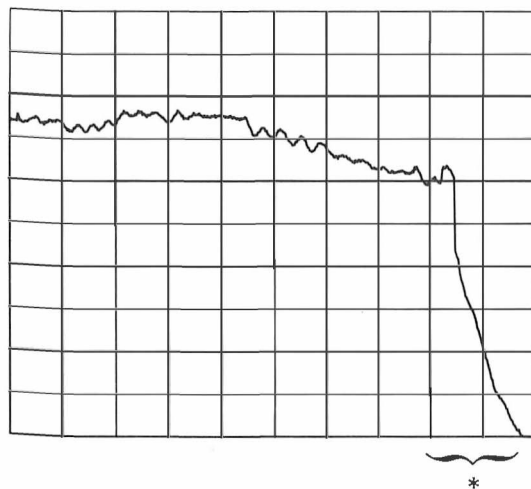

WAVEFORM B
*(TYPICAL SQUEGGING AREAS)

Figure 5-37. 8755C Display of Power Out Versus Frequency

5-35. UNLEVELED RF OUTPUT ADJUSTMENTS (Cont'd)

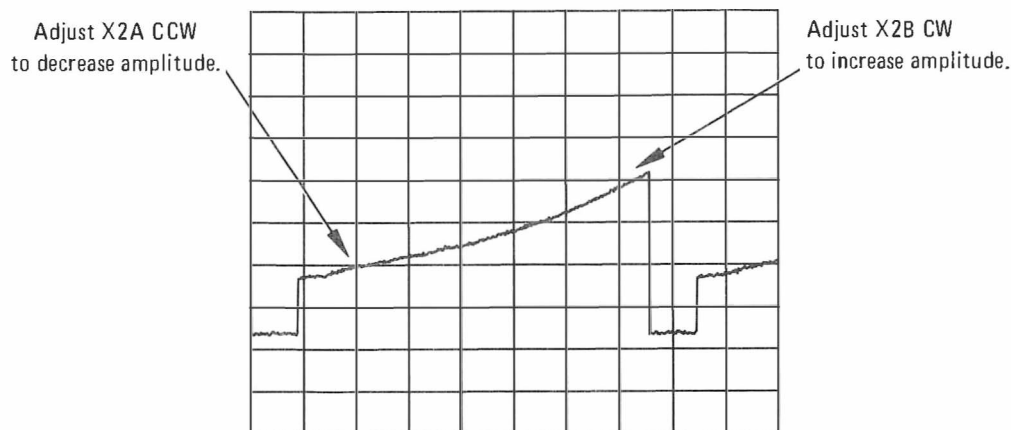

Figure 5-38. Oscilloscope Display of SRD Bias Waveform.

NOTE

The following steps assume that pressing [INSTR PRESET] will set the power level to 0 dBm. If the 8340A Under Test programs the power to other than 0 dBm during INSTR PRESET, change calibration constant Number 56 to 0. Record the original Power value so that you can restore it after all adjustments are made.

NOTE

In the following steps, adjust for maximum power in each band with no squegging.

8. Set 8755C to 1 dB/DIV. Access 8340A Calibration Constant Number 10 by entering the following: [SHIFT] [GHz] [1] [0] [Hz] [SHIFT] [MHz] [1] [2] [Hz] [SHIFT] [kHz] [2] [2] [Hz]. (Refer to Paragraph 5-15.) Use the rotary knob or the ENTRY keyboard and set Calibration Constant Number 10 to 1024.
9. For Band 2 (6.9 to 13.5 GHz), adjust A28R1 (OFF) (Figure 5-39) and A24R3 (X2A) for maximum power at the low frequency end. Adjust A28R8 (GAIN) and A24R4 (X2B) for maximum power at the high frequency end. These adjustments will interact so iterate for optimum settings. Observe the oscilloscope SRD Bias display for a slightly upward slope. Re-adjust X2A and/or X2B slightly if necessary to obtain the correct slope. Once the tracking has been optimized, store the trace in the 8750A Storage Normalizer by setting both 8755C inputs to R, setting the dB/DIV and offset of both 8755C channels the same. Press 8750A CH 1 INPUT, STORE INPUT, and RECALL. Activate the Auto Track function by pressing [SHIFT] [PEAK]. Iterate using A28R1 (OFF) and [SHIFT] [PEAK] to get the best overall results. When adjusting A28R1 (OFF), be sure to try both directions from the original optimized setting.

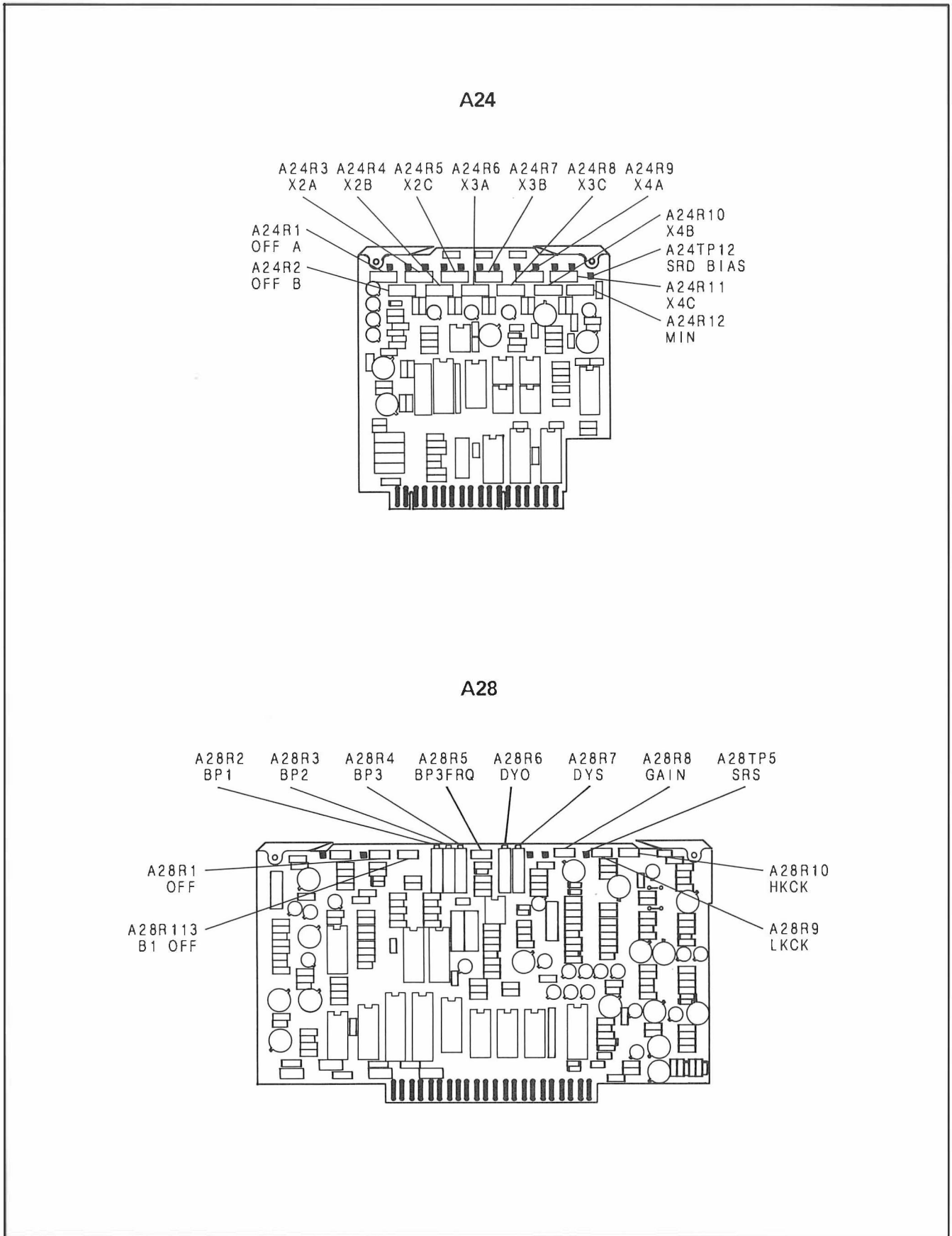

Figure 5-39. Bias, A24, and Tracking and Delay Compensation, A28 Adjustments Location

5-35. UNLEVELED RF OUTPUT ADJUSTMENTS (Cont'd)

10. For Band 1, press **[START FREQ]** and enter **[2] [.] [3] [GHz]**. Press **[STOP FREQ]** and enter **[7] [.] [0] [GHz]**. Adjust A28R113 (B1 OFF) for maximum power at the low frequency end. Access Calibration Constant Number 9 by entering the following: **[SHIFT] [GHz] [9] [Hz] [SHIFT] [MHz] [1] [2] [Hz] [SHIFT] [kHz] [2] [2] [Hz]**. Adjust Calibration Constant Number 9 for maximum power at the high frequency end.

Fundamental band sphere squegging may occur with these adjustments. The cause is different from the squegging in other bands. It is a function of input power to the SYTM and cannot be adjusted out. Normal operation of the instrument is below the power level where this occurs so it can be overlooked when making adjustments.

11. For Band 3, press **[START FREQ]** and enter **[1] [3] [.] [3] [5] [GHz]**. Press **[STOP FREQ]** and enter **[2] [0] [GHz]**. Adjust A24R6 (X3A) and Calibration Constant Number 11 for maximum power at the low frequency end. Access Calibration Constant Number 11 by entering the following: **[SHIFT] [GHz] [1] [1] [Hz] [SHIFT] [MHz] [1] [2] [Hz] [SHIFT] [kHz] [2] [2] [Hz]**. Adjust A28R2 (BP1) and A24R7 (X3B) for maximum power at the high frequency end. Once the tracking has been optimized, store the trace in the 8750A Storage Normalizer by setting both 8755C inputs to R, setting the dB/DIV and offset of both 8755C channels the same. Press 8750A CH 1 INPUT, STORE INPUT, and RECALL. Activate the Auto Track function by pressing **[SHIFT] [PEAK]**. Iterate using the Auto Track function and A28R2 (BP1) to match the stored trace as closely as possible. The adjustment of A28R2 should be tried in both directions from the original optimized settings.
12. For Band 4, press **[START FREQ]** and enter **[1] [9] [.] [8] [GHz]**. Press **[STOP FREQ]** and enter **[2] [6] [.] [5] [GHz]**. Access Calibration Constant Number 12 by entering the following: **[SHIFT] [GHz] [1] [2] [Hz] [SHIFT] [MHz] [1] [2] [Hz] [SHIFT] [kHz] [2] [2] [Hz]**. Adjust A24R9 (X4A) and Calibration Constant Number 12 for maximum power at the low frequency end, A28R3 (BP2) for maximum power at the center, and A28R4 (BP3), A28R5 (BP3FRQ), and A24R10 (X4B) for maximum power at the high frequency end. Once the tracking in Band 4 has been optimized, store the trace in the 8750A Storage Normalizer by setting both 8755C inputs to R, setting the dB/DIV and offset of both 8755C channels the same. Press 8755C CH 1 INPUT, STORE INPUT, and RECALL. Activate the Auto Track function by pressing **[SHIFT] [PEAK]**. Compare the resulting trace to the stored trace and readjust A28R3 (BP2), A28R4 (BP3), and A28R5 (BP2FRQ) as before. Substitute **[SHIFT] [PEAK]** for the adjustment of Calibration Constant Number 12.

The adjustments of A28R3, A28R4, and A28R5 should be tried in both directions during the iteration process with auto tracking. In some cases, better results are obtained by adjusting a control away from the optimum position then pressing **[SHIFT] [PEAK]** for Auto Tracking code.

SYTM DELAY COMPENSATION ADJUSTMENTS BY BAND**Description:**

Delay compensation is adjusted for minimum change in SYTM frequency tracking between a slow sweep and a fast sweep. Since the kick pulses affect delay, the kick pulse amplitude is adjusted as well.

5-35. UNLEVELED RF OUTPUT ADJUSTMENTS (Cont'd)

NOTE

SYTM kick pulses are generated at a SYTM retrace to reset SYTM magnetic state. The kick pulse has the effect of temporarily tuning the SYTM above the stop frequency and then below the start frequency. The following adjustments ensure that the pulse amplitude is sufficient to kick the SYTM frequency above and below the stop and start frequencies. The positive going voltage of the SRS waveform corresponds to the low frequency kick and the negative going voltage of the SRS waveform corresponds to the high frequency kick.

13. Connect the oscilloscope 10:1 probe to A28TP5 (SRS). Set oscilloscope to trigger at the end of the sweep ramp (i.e., NEG TRIGGER on 8340A SWEEP OUT signal). Set oscilloscope Channel A V/DIV switch to 0.1 (with 10:1 probe).
14. Press **[SAVE]** and enter **[1]** to save the instrument state set up in step 12. Temporarily set the 8340A to CW at 2.3 GHz (Press **[CW]** and enter **[2] [.] [3] [GHz]**). Press **[CONT]** Sweep key to give a sweep ramp for oscilloscope trigger. The oscilloscope should display a horizontal trace. Use the vertical position control to position the trace one division down from the top graticule line. This position represents the start frequency. Enter **[2] [6] [.] [5] [GHz]** and note the position of the oscilloscope trace. This represents the stop frequency. Press **[RECALL] [1]** to return to the previous instrument state.

NOTE

The range for the delay compensation calibration constants is 0 through 131. If the calibration constants do not provide enough range for the delay compensation, Calibration Constant Number 8 may be lowered, A28R6 and A28R7 readjusted in Band 4, and all of the delay compensation calibration constants will require readjustment. If the SYTM has been replaced, set Calibration Constant Number 8 to 120 initially.

15. Store the Band 4 trace of the 200 msec sweep in the 8750A Storage Normalizer by setting both 8755C inputs to channel R, setting the dB/Div and offset of both 8755C channels the same, press 8750A CH1 INPUT, STORE INPUT, and RECALL.
16. Press 8340A **[SWEEP TIME]** and **[AUTO]** to obtain the fastest sweep time for that frequency range.
17. Adjust A28R10 (HKCK) until the high frequency kick is about 300mV lower than the 26.5 GHz calibration line (Figure 5-40). Press **[SINGLE]** SWEEP key repetitively while adjusting A28R6 (DYO) and A28R7 (DYS) to match current 8755C trace with the stored trace to within 0.5 dB. Press **[CONT]** SWEEP and adjust A28R9 (LKCK) until the continuous sweep trace matches the stored trace to within 0.5 dB. Iterate between continuous sweep adjustments and single sweep adjustments to obtain the best match between the two 8755C traces. If the low frequency kick pulse cannot be made to fall above the 2.3 GHz calibration line and match the continuous sweep and single sweep traces, readjust A28R10 (HKCK) and repeat the procedure. The peaks of the oscilloscope kick pulse trace should be below the high frequency point (negative peak) and above the low frequency point (positive peak). Refer to the kick pulse waveform shown in Figure 5-40.

5-35. UNLEVELED RF OUTPUT ADJUSTMENTS (Cont'd)

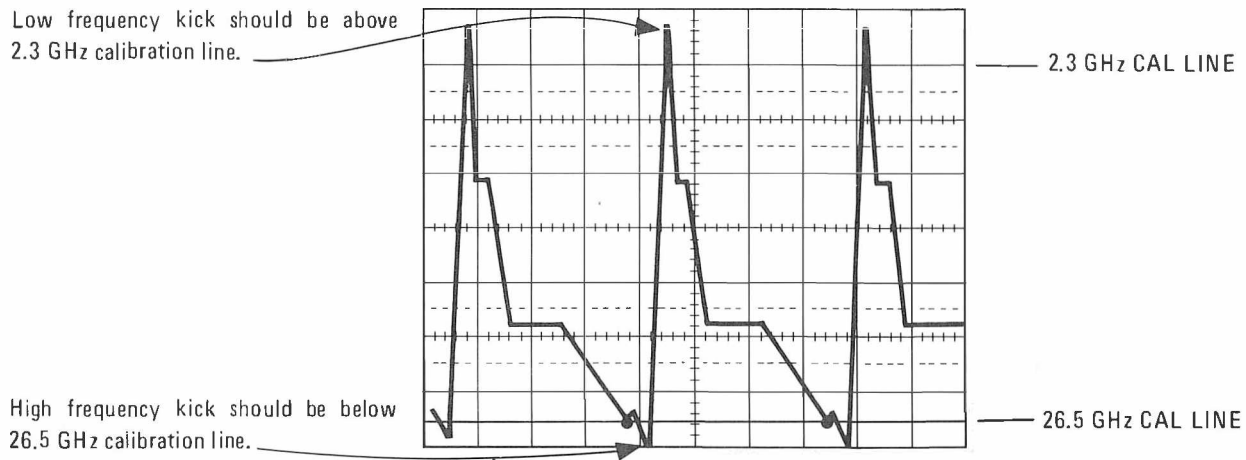

Figure 5-40. SYTM Kick Pulse Waveform.

18. Press **[START FREQ]** and enter **[1] [3] [.] [3] [5] [GHz]**. Press **[STOP FREQ]** and enter **[2] [0] [GHz]**. Press **[SWEEP TIME]** and enter **[2] [0] [0] [msec]**. Store this response using the storage normalizer as described in step 16 above. Press **[SWEEP TIME]** and **[AUTO]**. Access Calibration Constant Number 7 by entering the following: **[SHIFT] [GHz] [7] [Hz] [SHIFT] [MHz] [1] [2] [Hz] [SHIFT] [kHz] [2] [2] [Hz]**. Adjust Calibration Constant Number 7 to obtain the best match between the current trace and the stored trace. (Calibration Constant Number 7 must be within the range of zero to 131.)
19. Press **[START FREQ]** and enter **[6] [.] [9] [GHz]**. Press **[STOP FREQ]** and enter **[1] [3] [.] [5] [GHz]**. Press **[SWEEP TIME]** and enter **[2] [0] [0] [msec]**. Store this response using the storage normalizer as described in step 15 above. Press **[SWEEP TIME]** and **[AUTO]**. Access Calibration Constant Number 6 by entering the following: **[SHIFT] [GHz] [6] [Hz] [SHIFT] [MHz] [1] [2] [Hz] [SHIFT] [kHz] [2] [2] [Hz]**. Adjust Calibration Constant Number 6 to obtain the best match between the current trace and the stored trace. (Calibration Constant Number 6 must be within the range of zero to 131.)
20. Press **[START FREQ]** and enter **[2] [.] [3] [GHz]**. Press **[STOP FREQ]** and enter **[7] [GHz]**. Press **[SWEEP TIME]** and enter **[2] [0] [0] [msec]**. Store this response using the storage normalizer as described in step 15 above. Press **[SWEEP TIME]** and **[AUTO]**. Access Calibration Constant Number 5 by entering the following: **[SHIFT] [GHz] [5] [Hz] [SHIFT] [MHz] [1] [2] [Hz] [SHIFT] [kHz] [2] [2] [Hz]**. Adjust Calibration Constant Number 5 to match the current trace with the stored trace at the high frequency end. Typically the low frequency will not match within 0.5 dB. The traces are typically different because the fundamental band squegging may occur on the slow sweep and not on the fast sweep. (Calibration Constant Number 5 must be within the range of zero to 131.)

5-35. UNLEVELED RF OUTPUT ADJUSTMENTS (Cont'd)**HO2 NOTE**

THIS PAGE DOES NOT APPLY TO INSTRUMENTS EQUIPPED WITH OPTION HO2.

SYTM DELAY COMPENSATION ADJUSTMENTS AT FULL SWEEP MULTIBAND

21. Press [**INSTR PRESET**]. Press [**START FREQ**] and enter [2] [.] [3] [**GHz**]. Press [**SWEEP TIME**] and enter [1] [**sec**]. Press [**XTAL**] LEVELING. Press [**SHIFT**] [**PULSE**].

NOTE

The complete unlevelled multiband response cannot be viewed on the 8755C at 1 dB/Div resolution. In the following steps it will be necessary to adjust the 8755C offset to position a portion of the trace on the display before storing the trace using the storage normalizer.

22. Press [**SAVE**] [1] to store the HP 8340A 1 sec. instrument state. Press [**SWEEP TIME**] and [**AUTO**] to obtain the fastest sweep time for that range. Press [**SAVE**] [2] to store the HP 8340A fast sweep instrument state. Press [**RECALL**] [1] to return to the 1 sec. instrument state.

The response of Band 2 is about from the second to the fifth horizontal division. Adjust both 8755C reference levels to view the swept trace from the second to the fifth horizontal division. Store this trace using the storage normalizer as described in step 15 above. Press [**RECALL**] [2]. Access Calibration Constant Number 2 by entering the following: [**SHIFT**] [**GHz**] [2] [**Hz**] [**SHIFT**] [**MHz**] [1] [2] [**Hz**] [**SHIFT**] [**kHz**] [2] [2] [**Hz**]. Adjust Calibration Constant Number 2 for the best match between the current trace and the stored trace of Band 2. (Calibration Constant Number 2 must be within the range of zero to 131.)

23. Press [**RECALL**] [1]. The response of Band 3 is about from the fifth to the seventh horizontal division. Adjust both 8755C reference levels to view the swept trace from the fifth to the seventh horizontal division. Store this trace using the storage normalizer as described in step 15 above. Press [**RECALL**] [2]. Access Calibration Constant Number 3 by entering the following: [**SHIFT**] [**GHz**] [3] [**Hz**] [**SHIFT**] [**MHz**] [1] [2] [**Hz**] [**SHIFT**] [**kHz**] [2] [2] [**Hz**]. Adjust Calibration Constant Number 3 for the best match between the current trace and the stored trace of Band 3. (Calibration Constant Number 3 must be within the range of zero to 131.)

24. Press [**RECALL**] [1]. The response of Band 4 is about from the seventh to the tenth horizontal division. Adjust both 8755C reference levels to view the swept trace from the seventh to the tenth horizontal division. Store this trace using the storage normalizer as described in step 15 above. Press [**RECALL**] [2]. Access Calibration Constant Number 4 by entering the following: [**SHIFT**] [**GHz**] [4] [**Hz**] [**SHIFT**] [**MHz**] [1] [2] [**Hz**] [**SHIFT**] [**kHz**] [2] [2] [**Hz**]. Adjust Calibration Constant Number 4 for the best match between the current trace and the stored trace of Band 4. (Calibration Constant Number 4 must be within the range of zero to 131.)

5-35. UNLEVELED RF OUTPUT ADJUSTMENTS (Cont'd)

H02 NOTE

THIS PAGE DOES NOT APPLY TO INSTRUMENTS EQUIPPED WITH OPTION H02.

UNLEVELED SQUEGGING TEST USING THE 8566A SPECTRUM ANALYZER

Description:

The HP 8340A Under Test RF output signal is down converted using a Local Oscillator HP 8340A and a mixer. The IF output of the mixer is fed to a spectrum analyzer. Any squegging of the HP 8340A under test will appear as a spurious response on the IF signal.

This test should be performed after adjusting the SYTM tracking and delay, and the SRD unlevelled bias. Since unlevelled squegging can be difficult to see using the 8755C, this test is performed to determine if additional adjustments are required.

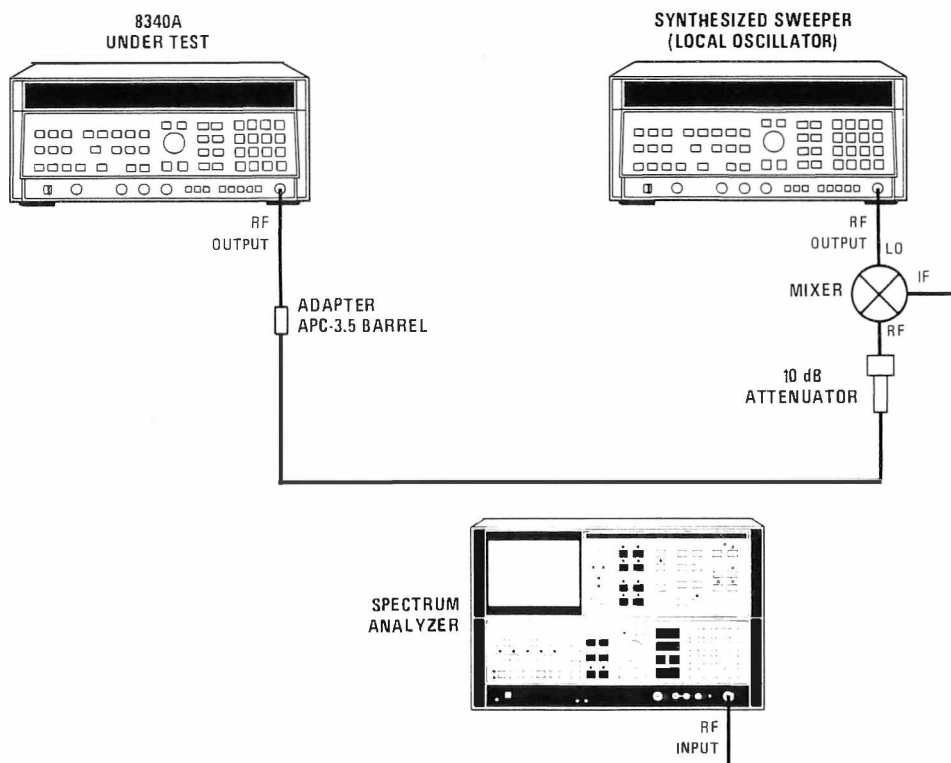

Figure 5-41. Unleveled Squegging Test Setup.

Equipment Required:

Synthesized Sweeper	HP 8340A (Opt. 001)
10 dB Attenuator	HP 8493C Option 010
Mixer	RHG DMS 1 - 26
Spectrum Analyzer	HP 8566A

25. Connect equipment as shown in Figure 5-41. Connect the mixer at the Local Oscillator (LO) HP 8340A RF output connector to obtain maximum mixer LO input level. Allow at least 30 minutes warm up time.

5-35. UNLEVELED RF OUTPUT ADJUSTMENTS (Cont'd)

26. Press the Local Oscillator 8340A **[INSTR PRESET]**. Press **[START FREQ]** and enter **[6] [.] [4] [GHz]**. Press **[STOP FREQ]** and enter **[1] [2] [.] [9] [GHz]**. Press **[POWER LEVEL]** and enter **[1] [0] [dBm]**. Press **[SHIFT] [CF]** and enter **[1] [0] [0] [MHz]** for a step size of 100 MHz. Press **[MANUAL] SWEEP** and enter **[6] [.] [4] [GHz]** to set the Local Oscillator to CW at 6.4 GHz. Press **[PEAK]** to turn on peaking.
27. Press the 8340A Under Test **[INSTR PRESET]**. Press **[START FREQ]** and enter **[7] [GHz]**. Press **[STOP FREQ]** and enter **[1] [3] [.] [5] [GHz]**. Press **[POWER LEVEL]** and enter **[2] [0] [dBm]**. UNLEVELED indicator should be on. Press **[SHIFT] [CF]** and enter **[1] [0] [0] [MHz]** for a step size of 100 MHz. Press **[MANUAL] SWEEP** and enter **[7] [GHz]**. The mixer IF frequency is now 600 MHz.
28. Set the Spectrum Analyzer for a FULL SPAN of 0–2.5 GHz. Set RES BW for 300 kHz. Set VIDEO BW for 100 kHz. Set START FREQ to 590 MHz. Set STOP FREQ to 800 MHz. Set REFERENCE LEVEL to –10 dBm. Set ATTEN to 0 dB. Press HOLD to retain these settings. The 600 MHz IF signal should be near the left side of the Spectrum Analyzer CRT.
29. Using the STEP UP key on both the 8340A Under Test and the Local Oscillator 8340A, step through Band 2, observing the Spectrum Analyzer display at each step. There may be responses due to mixing products. These will appear as low level signals. A squegging response will appear as a higher amplitude signal as shown in Figure 5-42. If squegging occurs at 8340A frequencies below 10 GHz, adjust A24R3 (X2A) slightly CCW to eliminate the squegging. If squegging occurs at frequencies above 10 GHz, adjust A24R4 (X2B) to eliminate the squegging. Note, if the control is adjusted and there is no effect on the response, the response is probably a mixing product.

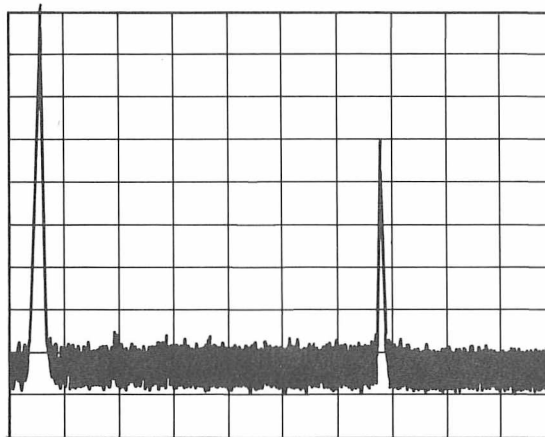

Figure 5-42. *Unlevelled Squegging Displayed on Spectrum Analyzer*

30. For Band 3, press the Local Oscillator 8340A **[START FREQ]** and enter **[1] [2] [.] [9] [GHz]**. Press **[STOP FREQ]** and enter **[1] [9] [.] [4] [GHz]**. Press **[MANUAL]** and enter **[1] [2] [.] [9] [GHz]**.
31. Press the 8340A Under Test **[POWER LEVEL]** and enter **[2] [0] [dBm]**. Press **[START FREQ]** and enter **[1] [3] [.] [5] [GHz]**. Press **[STOP FREQ]** and enter **[2] [0] [GHz]**. Press **[MANUAL]** and enter **[1] [3] [.] [5] [GHz]**.

5-35. UNLEVELED RF OUTPUT ADJUSTMENTS (Cont'd)

32. Using the step keys as described in step 30, step through Band 3. If squegging occurs below 15 GHz, adjust A24R6 (X3A) slightly CCW to eliminate the squegging. If squegging occurs above 15 GHz, adjust A24R7 (X3B).
33. For Band 4, press the Local Oscillator 8340A **[START FREQ]** and enter **[1] [9] [.] [4] [GHz]**. Press **[STOP FREQ]** and enter **[2] [5] [.] [9]**. Press **[MANUAL]** and enter **[1] [9] [.] [4] [GHz]**.
34. Press the 8340A Under Test **[START FREQ]** and enter **[2] [0] [GHz]**. Press **[STOP FREQ]** and enter **[2] [6] [.] [5] [GHz]**. Press **[POWER LEVEL]** and enter **[2] [0] [dBm]**. Press **[MANUAL]** and enter **[2] [0] [GHz]**.
35. Using the step keys as described in step 29, step through Band 4. If squegging occurs below 23 GHz, adjust A24R9 (X4A) slightly CCW to eliminate the squegging. If squegging occurs above 23 GHz, adjust A24R10 (X4B).

NOTE

If adjustments of the calibration constants were made in this procedure, the data thus stored in the "working memory area" should be copied to the "protected memory area" by pressing the following key sequence: [SHIFT] [MHz] [1] [4] [Hz] [SHIFT] [kHz] [5] [3] [4] [9] [Hz] [INSTR PRESET].

5-36. ALC ADJUSTMENTS

Reference:

Performance Test: Maximum Leveled Output Power and Accuracy
 Service Section: RF Section

LOGGER TEMPERATURE COMPENSATION

Description:

NOTE

The following logger temperature compensation procedure should only be done if either A11 or A12 Detector is replaced.

The logger in A25 has temperature compensation in both high and low bands. This procedure calculates the values for the four factory-selected resistors in the temperature compensation circuit.

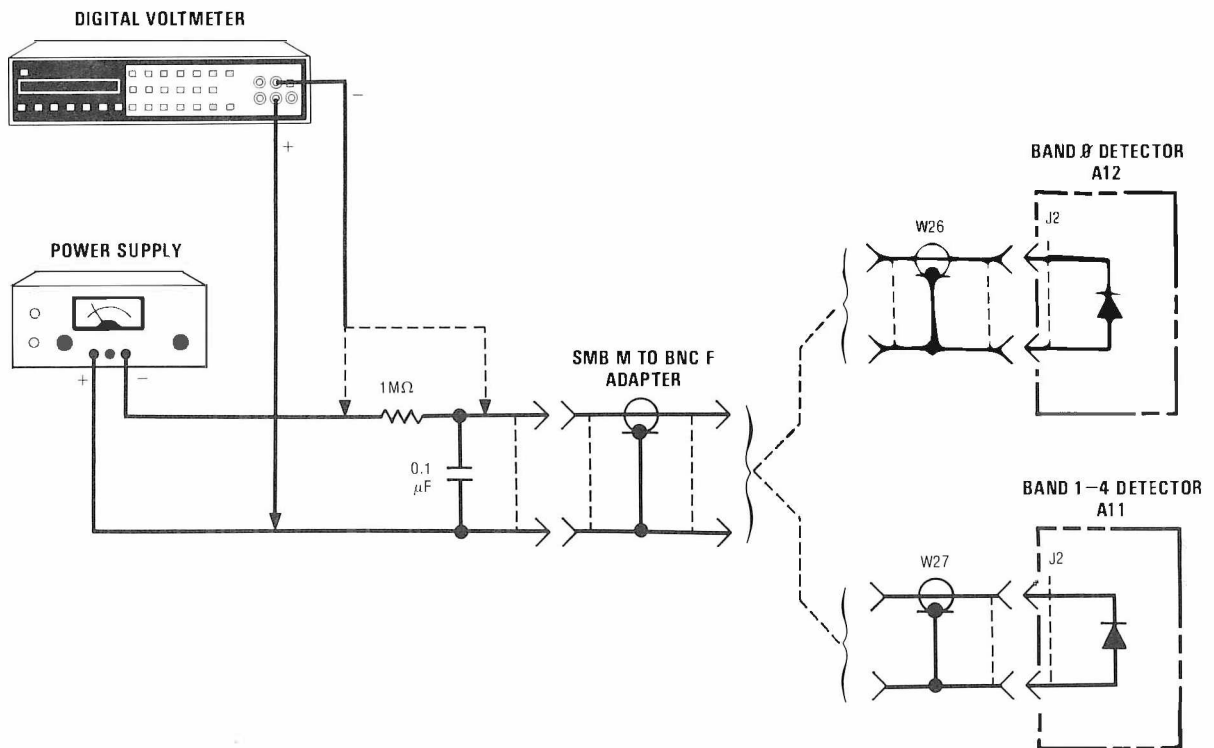

Figure 5-43. Logger Temperature Compensation Test Setup

5-36. ALC ADJUSTMENTS (Cont'd)**Equipment Required:**

Power Supply.....	HP 6294A
Digital Voltmeter (DVM)	HP 3455A
1 Megohm Resistor.....	HP Part Number 0757-0059
0.1 UF Capacitor.....	HP Part Number 0160-0168
Extender Board	HP Part Number 08350-60031

Procedure:

1. Disconnect AC power cable from the 8340A Under Test and allow it to cool for at least two hours.
2. Disconnect cables W26 and W27 from A25J2 and A25J1 respectively (Figure 5-44), and remove A25 PC board from the instrument.

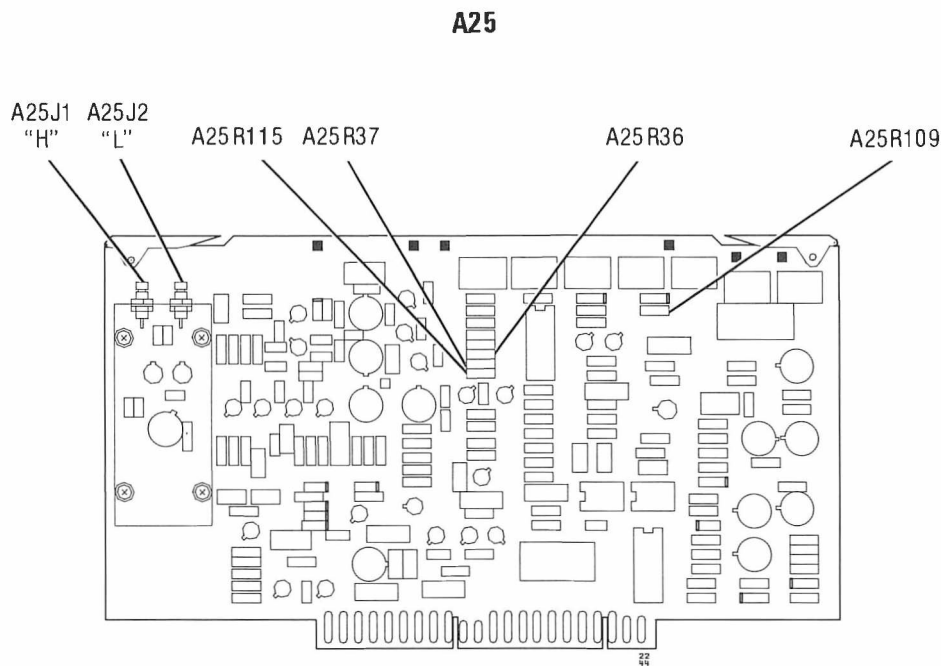

Figure 5-44. ALC Detector A25 Temperature Compensation Adjustments Location

3. Install Extender Board in place of A25.
4. Set DVM for Ohms measurement and connect the input between pins 4 and 26 of the extender board. Note the resistance measured. This value is thermistor resistance, R_T , and will be used for calculations in later steps.

5-36. ALC ADJUSTMENTS (Cont'd)

5. Connect equipment as shown in Figure 5-43 with cable W27 connector connected to SMB-to-BNC adapter.
6. Connect the DVM across the output terminals of the Power Supply and adjust the power supply output for 5.00 ± 0.01 Vdc. Move the DVM connections back to the SMB-to-BNC adapter as shown in Figure 5-43.
7. Note indication on DVM. This value is V_{VM} for high band and will be used for calculations in step 8.
8. Calculate "Corrected Video Resistance in Hi Band", R_{VH} , as follows:

$$R_{VH} = (R_{VM} - 100) \times 24000 / (R_T + 4000)$$

where:

R_{VH} = Corrected Video Resistance in High Band

R_{VM} = $V_{VM} \times 200$ Ohms/mV

V_{VM} = Value measured in step 7 above.

R_T = Thermistor Resistance measured in step 4 above.

9. Use the value of R_{VH} found in step 8 above and select resistance values for A25R36 and A25R37 from Table 5-7.
10. Disconnect high band detector A11 cable W27 from SMB-to-BNC adapter and connect low band detector A12 cable W26 to adapter as shown in Figure 5-43.
11. Connect DVM at output of Power Supply and check that the output is still at 5.00 ± 0.01 Vdc. Move the DVM connections back to the SMB-to-BNC adapter as shown in Figure 5-43.
12. Note indication on DVM. This value is V_{VM} for low band and will be used for calculations in step 13.
13. Calculate "Corrected Video Resistance in Low Band", R_{VL} , as follows:

$$R_{VL} = (R_{VM} - 680) \times 24000 / (R_T + 4000)$$

where:

R_{VL} = Corrected Video Resistance in Low Band

R_{VM} = $V_{VM} \times 200$ Ohms/mV

V_{VM} = Value measured in step 12 above.

R_T = Thermistor Resistance measured in step 4 above.

14. Use the value of R_{VL} found in step 13 above and select resistance values for A25R109 and A25R115 from Table 5-8.

5-36. ALC ADJUSTMENTS (Cont'd)*Table 5-7. Selected Values of High Band Temperature Compensation Resistors in A25*

R_{VH} (Ohms)	A25 R36 (Ohms)	A25 R37 (Ohms)
800-870	9090	6190
870-950	8250	5620
950-1050	7500	5620
1050-1160	6810	5110
1160-1270	6190	4640
1270-1380	5620	4220
1380-1490	5110	4220
1490-1600	4640	3830

Table 5-8. Selected Values of Low Band Temperature Compensation Resistors in A25

R_{VL} (Ohms)	A25 R109 (Ohms)	A25 R115 (Ohms)
800-870	3830	9090
870-950	3480	8250
950-1050	3160	7500
1050-1160	2870	6810
1160-1270	2370	6190
1270-1380	2150	5620
1380-1490	1960	5110
1490-1600	1620	4640

5-36. ALC ADJUSTMENTS (Cont'd)

ALC ADJUSTMENTS

Description:

The ALC detectors have a linear region. Below the linear region the detector response is non-linear. The ALC circuit attempts to compensate for the non-linear regions such that the overall response of the ALC loop is linear over a 40 dB range from -20 dBm to +20 dBm. Since there is a separate detector and modulator for high band (Bands 1-4) and low band (Band 0), there are separate adjustments for high band and low band.

The 8340A is set to a CW frequency within the band to be adjusted. The RF attenuator and ALC is set for de-coupled operation (controlled separately). The RF output level is set using the ENTRY keys. The power is measured with a power meter and if necessary adjustments are made until the power meter indication is correct at each 8340A power level.

Equipment Required:

Power Meter.....	HP 436A
Power Sensor.....	HP 8485A

Procedure:

NOTE

The ALC circuit contains several adjustment controls and the adjustment includes changing calibration constants stored in memory. All of the adjustments in each band interact with each other. In addition, the high band 0 dBm adjustment affects the low band, and the high band +18 dBm adjustment affects the low band. Before making any adjustments, check the operation of the ALC circuit as described below and make adjustments only if necessary.

NOTE

ALC accuracy problems for levels above +10 dBm may be due to parasitic oscillations in the log converter. If so, these may usually be cured by removing capacitor A25C11. This capacitor should be left in place if no oscillations occur to give best log amplifier rise time.

NOTE

In the following procedures, do not put P.C. boards on extender boards.

15. Connect equipment as shown in Figure 5-45. Calibrate and zero the power meter. Allow one hour warmup time. Connect the power sensor to the 8340A RF output. Press 8340A [INSTR PRESET]. Press [CW] and enter [4] [.] [5] [GHz]. Press 8340A [RF] key to turn the RF OFF and zero the power meter. To ensure that the power meter is properly zeroed, select "WATT" mode, and press the ZERO button two or three times. After the power meter is zeroed, the power meter should indicate ≤ 0.02 on the most sensitive range. Press [RF] to turn the RF ON. Press [PEAK] to center the SYTM frequency response to the YO signal. Press [SHIFT] [PWR SWP] to decouple the RF

5-36. ALC ADJUSTMENTS (Cont'd)

attenuator and ALC. Enter [0] [dBm]. If the display does not indicate ATTEN=0 dB, press STEP keys as necessary to select 0 dB attenuation.

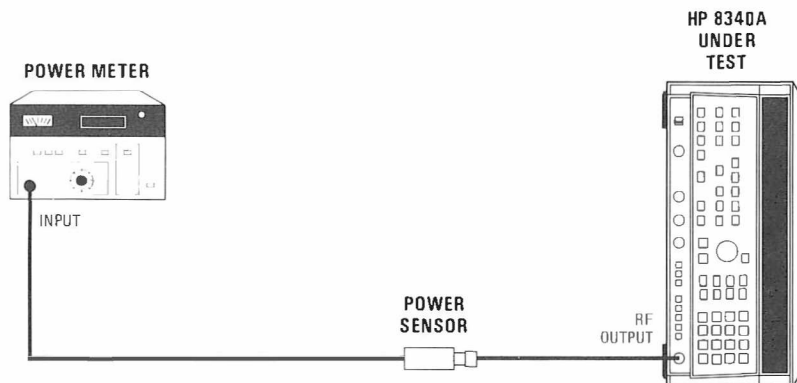

Figure 5-45. ALC Adjustment Test Setup

NOTE

When the power level is changed significantly, it may take as long as one minute for the power meter indication to be accurate. After making a power level change, wait until the power meter indication stabilizes before making any adjustments.

16. Refer to Table 5-9 below, enter the appropriate 8340A power level and check the power meter indication. Check the indication at each power level and note the amount of error before making any adjustments. If necessary, adjust the appropriate controls shown in the table to adjust the power level to be within the test limit shown.

Adjustments are iterative. Adjust in the following order:

0 dBm, -10 dBm, -20 dBm, -10 dBm, 0 dBm, +10 dBm, +18 dBm, and +10 dBm.

See Figure 5-46 for more information that may help to reduce the number of iterations required. For example, if the +18 dBm indication is 0.1 dB low (+17.9 dBm), adjust for 0.05 dB high (+18.05 dBm). Then when the +10 is adjusted to +10 dBm, the +18 will move close to the correct level.

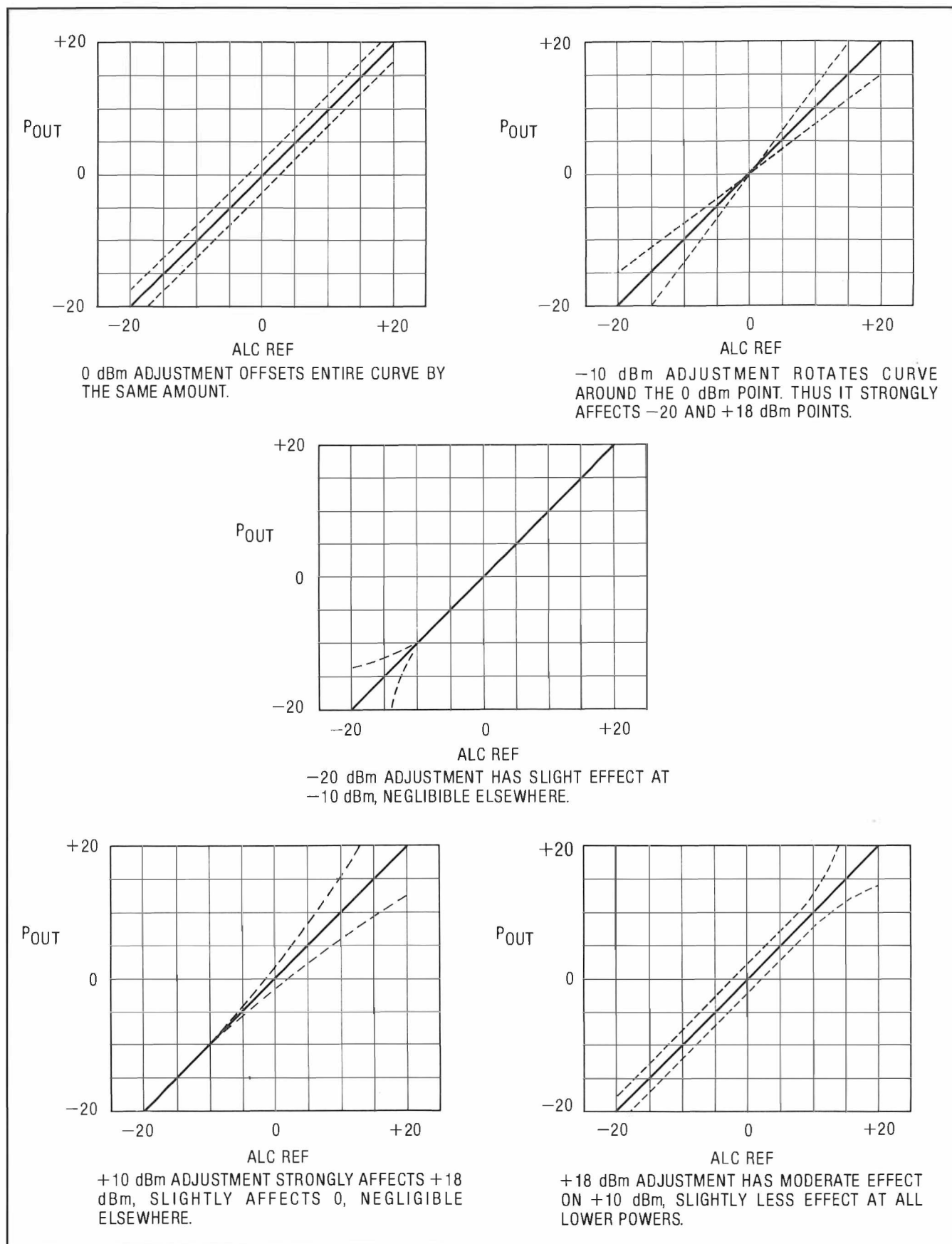

Figure 5-46. Typical ALC Adjustment Response Curves

5-36. ALC ADJUSTMENTS (Cont'd)

Table 5-9. High Band ALC Adjustment

8340A Power Level	Associated Adjustment	Check Limit	Adjustment Limit
-20 dBm	A25R34 (H-20)	0.3 dB	0.2 dB
-10 dBm	Calibration Constant #47*	0.1 dB	0.02 dB
0 dBm	Calibration Constant #44*	0.1 dB	0.02 dB
10 dBm	A25R39 (H+10)	0.1 dB	0.02 dB
18 dBm	A25R24 (+18)**	0.2 dB	0.05 dB

* Access Calibration Constant Number 47 by entering the following: [SHIFT] [GHz] [4] [7] [Hz] [SHIFT] [MHz] [1] [2] [Hz] [SHIFT] [kHz] [2] [2] [Hz]. Use [STEP] key to change Cal. Constant Number to 44.

** On some boards, this adjustment is labeled "+20."

5-36. ALC ADJUSTMENTS (Cont'd)

17. If all power meter indications are within the test limits, check at power levels from -20 dBm to +20 dBm in 5 dB steps.
18. Press **[CW]** and enter **[1] [.] [5] [GHz]**. Press **[SHIFT] [PWR SWP]** to decouple the RF attenuator and ALC. Enter **[0] [dBm]**. Press **[RF]** to turn the RF OFF. Zero the power meter as described in step 1. The low band (Band 0) contains broadband noise. If the power meter is properly zeroed, the broadband noise will be compensated and power measurements will be more accurate. Press **[RF]** to turn the RF ON.
19. Refer to Table 5-10 below, enter the appropriate 8340A power level and check the power meter indication. Check the indication at each power level and note the amount of error before making any adjustments. If necessary adjust the appropriate controls shown in the table to adjust the power level to be within the test limits.

Adjustments are iterative. Adjust in the following order:

0 dBm, -10 dBm, -20 dBm, -10 dBm, 0 dBm, and +10 dBm.

Table 5-10. Low Band ALC Adjustment

8340A Power Level	Associated Adjustment	Check Limit	Adjustment Limit
-20 dBm	A25R33 (L-20)	0.3 dB	0.2 dB
-10 dBm	Calibration Constant #46*	0.1 dB	0.02 dB
0 dBm	A25R108 (LOFS)	0.1 dB	0.02 dB
10 dBm	A25R38 (L+10)	0.1 dB	0.02 dB
There is no low band +20 dBm adjustment.			
* Access Calibration Constant Number 46 by entering the following: [SHIFT] [GHz] [4] [6] [Hz] [SHIFT] [MHz] [1] [2] [Hz] [SHIFT] [kHz] [2] [2] [Hz] .			

20. If all power meter indications are within the test limit, check at power levels from -20 dBm to +10 dBm in 5 dB steps.

NOTE

If adjustments of the calibration constants were made in this procedure, the data thus stored in the "working memory area" should be copied to the "protected memory area" by pressing the following key sequence: [SHIFT] [MHz] [1] [4] [Hz] [SHIFT] [kHz] [5] [3] [4] [9] [Hz] [INSTR PRESET].

5-36. ALC ADJUSTMENTS (Cont'd)

EXTERNAL LEVELING ADJUSTMENTS

NOTE

The negative external Xtal leveling adjustments include two variable resistor adjustments (+6 dBV and -60 dBV) and two calibration constant adjustments (-30 dBV and 0 dBV). These adjustments interact similar to the ALC adjustments. See Figure 5-47 for more information that may help to reduce the number of iterations required. Note that the curve rotates about the -30 dBV level.

21. Connect a negative Xtal detector to the 8340A RF output. Connect a BNC Tee at the detector output. Connect a BNC cable from one output of the Tee to the 8340A LEVELING EXT INPUT. Connect another BNC cable from the BNC Tee to a DVM. Set the DVM for a floating input. If using an HP 3455A or 3456A DVM, put a 0.1 UF capacitor across its terminals.

Make adjustments in the following order:

-30 dBV, 0 dBV, +6 dBV, 0 dBV, -30 dBV, and -60 dBV.

22. Press [**INSTR PRESET**]. Press [**CW**] and enter [**4**] [**.**] [**5**] [**GHz**]. Press [**XTAL LEVELING**]. The ENTRY DISPLAY should indicate ATN: 0 dB, REF -30.00 dBV. Adjust calibration constant Number 45 for a DVM indication of $-31.6 \text{ mV} \pm 0.3 \text{ mV}$. Access Calibration Constant Number 45 by entering the following: [**SHIFT**] [**GHz**] [**4**] [**5**] [**Hz**] [**SHIFT**] [**MHz**] [**1**] [**2**] [**Hz**] [**SHIFT**] [**kHz**] [**2**] [**2**] [**Hz**].
23. Press [**POWER LEVEL**] and enter [**0**] [**dBm**]. Adjust calibration constant Number 48 for a DVM indication of $-1.00 \text{ volts} \pm 0.01 \text{ volts}$. Access Calibration Constant Number 48 by entering the following: [**SHIFT**] [**GHz**] [**4**] [**8**] [**Hz**] [**SHIFT**] [**MHz**] [**1**] [**2**] [**Hz**] [**SHIFT**] [**kHz**] [**2**] [**2**] [**Hz**].
24. Press [**POWER LEVEL**] and enter [**6**] [**dBm**]. The ENTRY DISPLAY REF level should be +6 dBV. Adjust A25R88 (EXHI) for a DVM indication of $-2.00 \text{ volts} \pm 0.02 \text{ volts}$. The +6 dB adjustment will affect the 0 dBV level as well. To minimize the number of iterations, over adjust the +6 dBV level, then when the 0 dBV level is adjusted, the +6 dBV level will be close. For example, if the +6 dBV indication is 0.1V low, adjust for 0.15V high.
25. Press [**XTAL**] and enter [**-**] [**6**] [**0**] [**dBm**]. Use the down [**STEP**] key to set the RF attenuator to 20 dB. If the 8340A does not include an RF attenuator, connect a 20 dB pad between the RF output and the Xtal detector. Adjust A25R80 (EX-) for a DVM indication of $-1.000 \text{ mV} \pm 0.01 \text{ mV}$. Repeat all negative external leveling adjustments, in the order given, until all DVM indications are within $\pm 1\%$. Note: Return the RF attenuator to zero except for the -60 dBV adjustment.
26. Connect a positive Xtal detector in place of the negative Xtal detector. With the RF attenuator set to 20 dB and the REF set to -60 dBV, adjust A25R84 (EX+) for $+1.000 \text{ mV} \pm 0.01 \text{ mV}$.

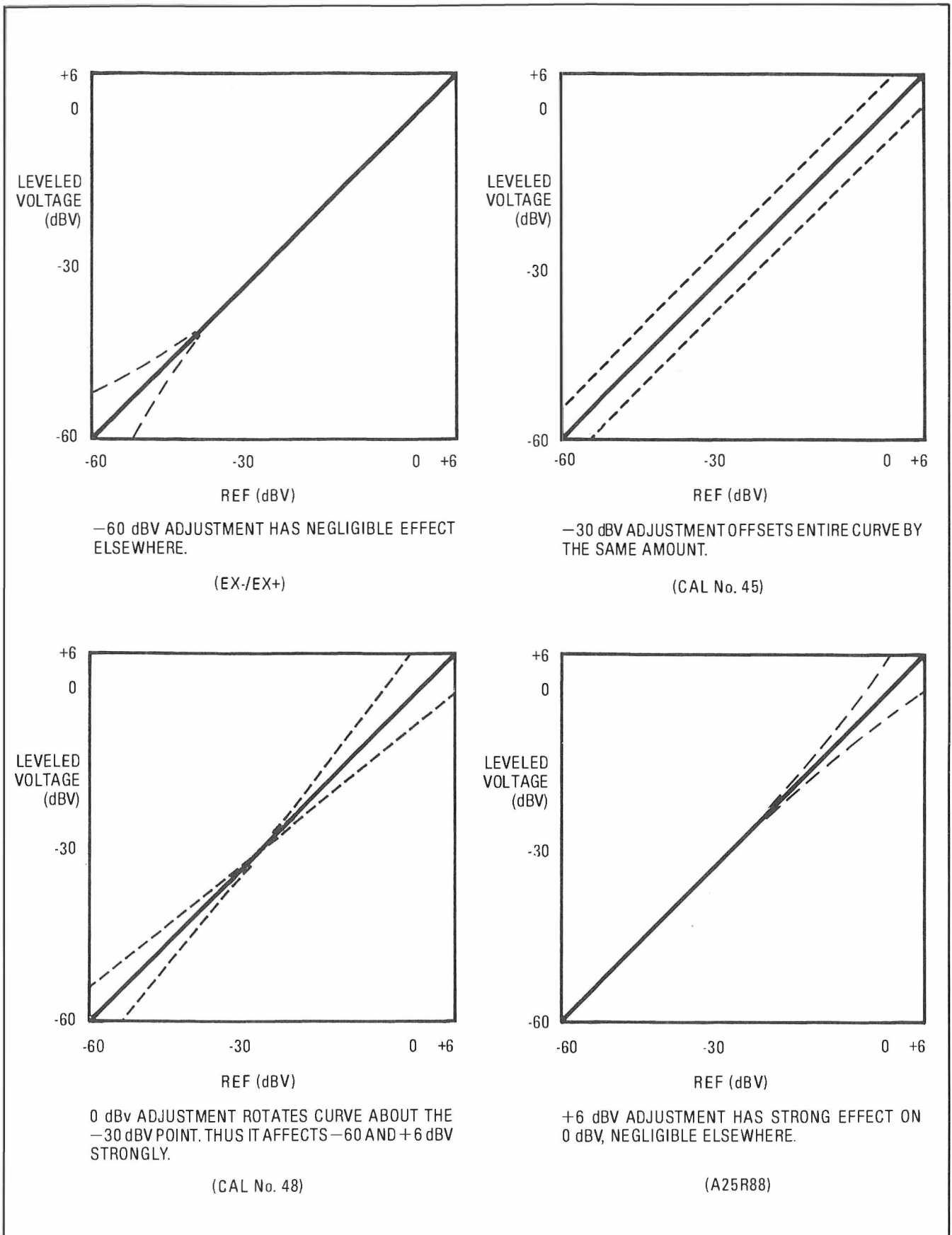

Figure 5-47. Typical External Leveling Response Curves

5-36. ALC ADJUSTMENTS (Cont'd)

ADJUST AM OFFSET

27. Connect Power Sensor to 8340A RF OUTPUT. Press **[INSTR PRESET]**. Press **[CW]** and enter **[1] [GHz]**. Power level should be 0 dBm. Disconnect any AM inputs. Access Calibration Constant Number 43 by entering the following: **[SHIFT] [GHz] [4] [3] [Hz] [SHIFT] [MHz] [1] [2] [Hz] [SHIFT] [kHz] [2] [2] [Hz]**. Adjust Calibration Constant Number 43 for no more than 0.05 dB change in power meter indication when turning AM on then off.

NOTE

If adjustments of the calibration constants were made in this procedure, the data thus stored in the "working memory area" should be copied to the "protected memory area" by pressing the following key sequence: **[SHIFT] [MHz] [1] [4] [Hz] [SHIFT] [kHz] [5] [3] [4] [9] [Hz] [INSTR PRESET]**.

AM GAIN ADJUSTMENT

28. Set up the following equipment as shown in Figure 5-48a with the power supply set to 0.0 Vdc. Allow the equipment to warm up for at least 30 minutes.

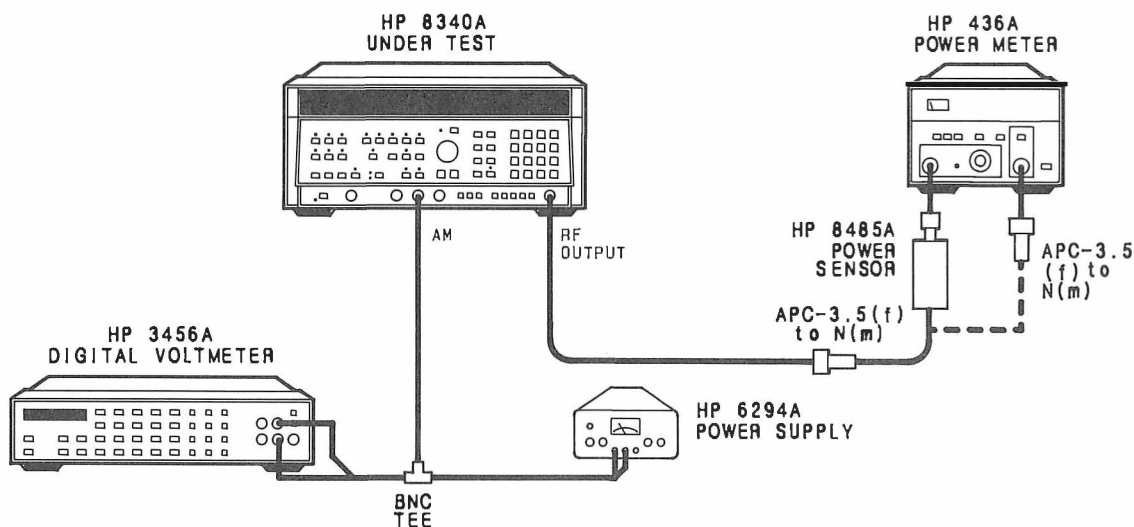

Figure 5-48a. AM GAIN Adjustment Test Setup

29. Calibrate the power meter and then set the calibration factor switch for a 1.5 GHz measurement. Connect the power sensor to the HP 8340A RF output.
30. Press the following key sequence on the HP 8340A:
[INSTR PRESET]
[CW] [1] [.] [5] [GHz]
[POWER LEVEL] [−] [5] [dBm]
[AM].
31. Adjust the power supply for 0.0 Vdc. press **dB[REF]** on the power meter (the power meter will now indicate the power level changes from this reference).
32. Adjust power supply for +0.3 Vdc. Power meter indication should be between 2.18 to 2.38 dB. If the indication is not in this range, adjust A26R91 (AM GAIN) for a power meter indication within the given range.

5-36. ALC ADJUSTMENTS (Cont'd)

33. Adjust power supply for -0.3 Vdc. Power meter indication should be between -2.91 and -3.29 dB. If the indication not in this range, adjust A26R91 (AM GAIN) for a power meter indication within the given range.
34. Repeat steps 32 and 33 until the power level requirements are met for each step.

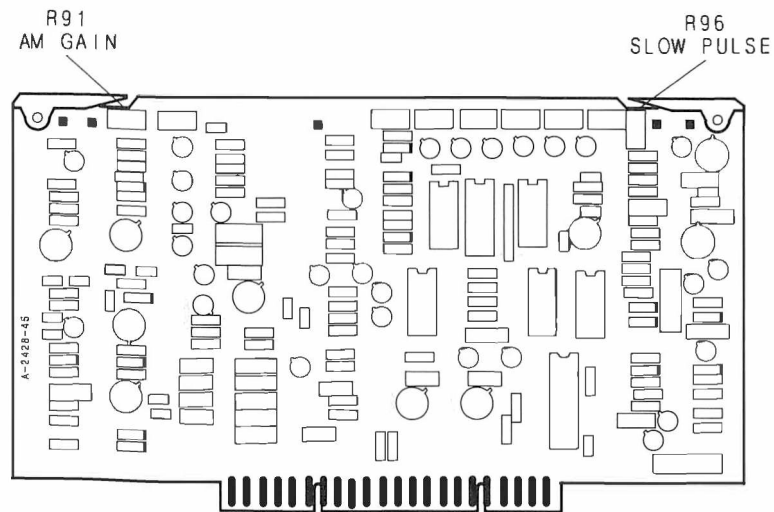

Figure 5-48b. AM Gain and Slow Pulse Adjustment Locations

5-36a. SLOW PULSE MODULATION ADJUSTMENT

Specification

Table 5-10b. Pulse Modulation Rise and Fall Time Adjustment Tolerances

Overshoot: <20%

Rise (T_R) and Fall (T_F) Times: 1 to 6 microseconds

Description

This adjustment optimizes pulse overshoot and Rise/Fall time in the instrument's "Slow Pulse" circuitry (located on the A26 linear modulator assembly). Slow pulse allows the HP 8340A to modulate its RF output at a 27.8 kHz rate. The 27.8 kHz signal is provided by connecting the modulation drive from an HP 8755C or 8756A network analyzer to the DUT's AM input.

The slow pulse circuitry is activated by pressing **[SHIFT] [PULSE]** on the front panel.

The HP 8340A under test RF output frequency is down converted to 50 MHz using a mixer and a second HP 8340A as a local oscillator. The 50 MHz IF signal is amplified and applied to an oscilloscope. The HP 8340A under test is pulsed using a 27.8 modulator drive from an HP 8755C. The modulator drive is also applied to the oscilloscope. the oscilloscope is used to measure the pulse envelope rise and fall times. Refer to Figure 5-49a Pulse Definitions.

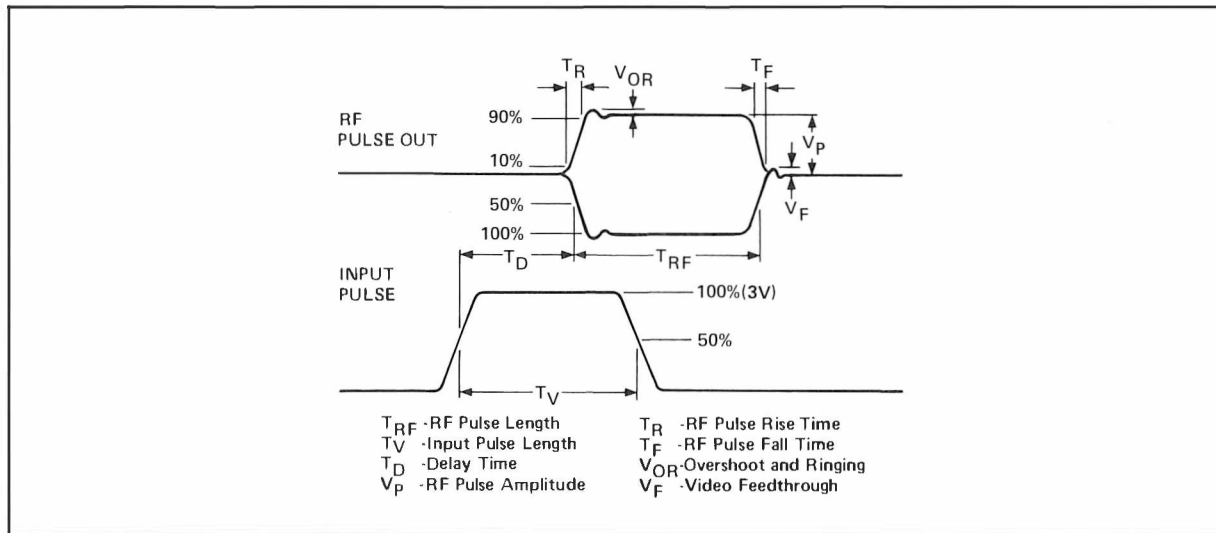

Figure 5-49a. Pulse Definitions

Equipment

Local Oscillator	HP 8340A Opt. 001
Network Analyzer	HP 8755C
Display	HP 182T
Amplifier	HP 8447F
Oscilloscope	HP 1741A
Adapter	HP P/N 5061-5311
10 dB Attenuator	HP 8493C Opt. 010
Mixer	RHG DMS 1-26
Low Pass Filter (LPF)	HP P/N 08340-60176

5-36a. SLOW PULSE MODULATION ADJUSTMENT (Cont'd)

Procedure

1. Connect equipment as shown in Figure 5-49b. Connect the mixer directly to the local oscillator RF output to obtain maximum LO drive to the mixer. connect the BNC tee directly to the HP 8340A AM connector. Allow at least 30 minutes warm up time.

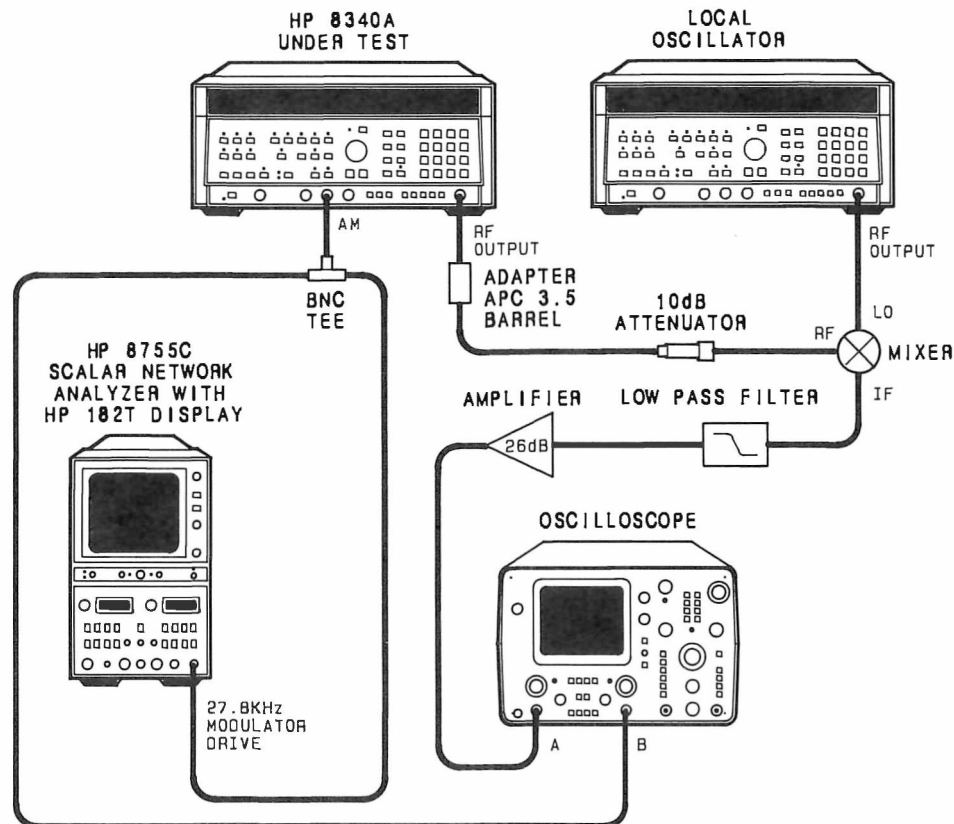

Figure 5-49b. Pulse Modulation Rise and Fall Time Test Setup

2. Set the oscilloscope up as follows:

Channel A — 50 Ohm input. when the signal is present on the oscilloscope, adjust vertical position and gain so the lower portion of the signal is at the 0% graticule, and the top of the pulse is at the 100% graticule. Use the averaged amplitude of the signal when setting up the 100% point, not the peak value.

Channel B — DC input, 5V/div.

Horizontal Controls — Chop Mode, trigger on Channel B, 2 usec/div.

5-36a. SLOW PULSE MODULATION ADJUSTMENT (Cont'd)

- Press **[INSTR PRESET]** on both the HP 8340A under test and the local oscillator HP 8340A. Press the HP 8340A under test **[CW]** key and enter **[2] [GHz]** and press **[SHIFT] [PULSE]**. Press the local oscillator HP 8340A **[CW]** key and enter **[1] [.] [9] [5] [GHz]**. The IF frequency is then 50 MHz. Set the local oscillator HP 8340A for +10 dBm or maximum leveled output. The HP 8340A under test RF power should be 0 dBm.

NOTE

For best accuracy in this test, the Local Oscillator drive to the mixer should be $\geq +6$ dBm. The HP 8340A Option 001 used as the LO will typically produce +6 dBm at any frequency, although it is only guaranteed to produce +4 dBm above 23 GHz. If +6 dBm is not available at a test frequency, try a slightly different frequency and be sure to have PEAK on.

- Select oscilloscope channel A input only. Adjust the horizontal sweep period so the entire pulse width is visible on the oscilloscope display. Adjust the vertical gain and position so that the pulse OFF is at the 0% graticule line and the pulse ON is a 100% graticule line. The ON portion of the pulse that is nearer to the trailing edge of the pulse should be used as the 100% reference point. The overshoot component of the pulse will then be clearly seen exceeding the 100% graticule.
- Overshoot should not exceed 20%. Note the actual Overshoot value for later reference.
- Repeat steps 4 and 5 at DUT frequencies of 3 through 26.0 GHz at 1 GHz steps, noting the overshoot at each frequency point. Make a last measurement at 26.5 GHz. At each frequency point, set the local oscillator HP 8340A CW frequency to be 50 MHz below that of the DUT.
- Review the worst case Overshoot value; if it is within 20%, proceed to step 9. If the worst case Overshoot is out of tolerance, set the DUT and LO to the worst case frequencies and adjust A26R96 until the Overshoot meets tolerance.
- Repeat steps 4 through 7 until overshoot is within tolerance at all frequency points.
- Adjust the oscilloscope as in step 4 except the horizontal period should be adjusted so only the rising edge of the pulse is viewed. Refer to Figure 5-49c. Set the 10% point of the modulation envelope at the center vertical graticule line.

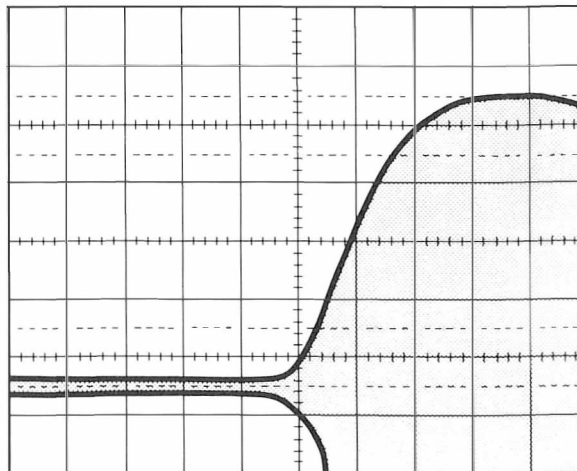

Figure 5-49c. Pulse Modulation Rise Time Waveform

5-36a. SLOW PULSE MODULATION ADJUSTMENT (Cont'd)

10. Set the DUT CW frequency to 2 GHz and the LO CW frequency to 1.95 GHz. Take note of the rise time for future reference. Rise time should be within 1 to 6 microseconds (10% to 90% points).
11. Repeat steps 9 and 10 at DUT frequencies of 3 through 26.0 GHz at 1 GHz steps, noting the rise time at each frequency point. Make a last measurement at 26.5 GHz. At each frequency point, set the local oscillator HP 8340A CW frequency to be 50 MHz below that of the DUT.
12. Take note of the worst case rise time, if this point is within 1 to 6 microseconds, proceed to step 14. If this point is out of tolerance, adjust A26R96 until tolerance is met.
13. Repeat steps 4 through 12 until overshoot and rise time at all listed frequencies are within tolerance. (Tolerances given for rise and fall time, as well as overshoot, are not warranted specifications.)
14. Adjust the oscilloscope horizontal position control to view the modulation envelope fall time. Position the waveform so that the 90% point of the modulation envelope crosses a convenient vertical graticule. Refer to Figure 5-49d.

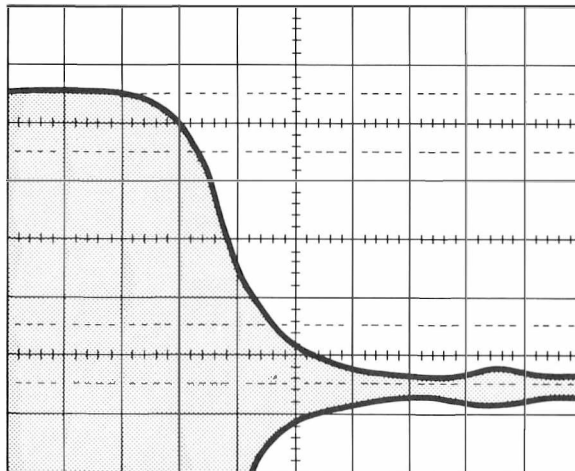

Figure 5-49d. Pulse Modulation Fall Time Waveform.

15. Set the DUT CW frequency to 2 GHz and the LO CW frequency to 1.95 GHz. Take note of the fall time for future reference. Fall time should be within 1 to 6 microseconds (10% to 90% points).
16. Repeat steps 14 and 15 at DUT frequencies of 3 through 26.0 GHz at 1 GHz steps, noting the fall time at each frequency point. Make a last measurement at 26.5 GHz. At each frequency point, set the local oscillator HP 8340A CW frequency to be 50 MHz below that of the DUT.
17. Take note of the worst case fall time, if this point is within 1 to 6 microseconds, this test has been completed. If this point is out of tolerance, adjust A26R96 until tolerance is met.
18. Repeat steps 4 through 17 until overshoot, rise time, and fall time at all listed frequencies are within tolerance.

5-37. LEVELED RF OUTPUT ADJUSTMENTS

H02 NOTE

THIS PAGE DOES NOT APPLY TO INSTRUMENTS EQUIPPED WITH OPTION H02.

Reference:

Performance Test: Maximum Leveled Output Power and Accuracy
 Service Section: RF Section

Description:

In this procedure, the RF Output signal is checked in leveled mode. A Frequency Response Test Set (8755C) is used to check for signal flatness and for the possible occurrence of "squegging." Squegging is an undesirable parasitic oscillation in the RF output signal.

In the next procedure, the ALC loop gain in each band is adjusted for optimum operation.

Next, a section is given using an HP 8340A internal program called "Auto Track." This program automatically sets the SYTM tracking.

A final section checks the RF Output signal with a Spectrum Analyzer (8566A) for squegging in any of the bands and allows a last fine adjustment to eliminate any squegging that is observed.

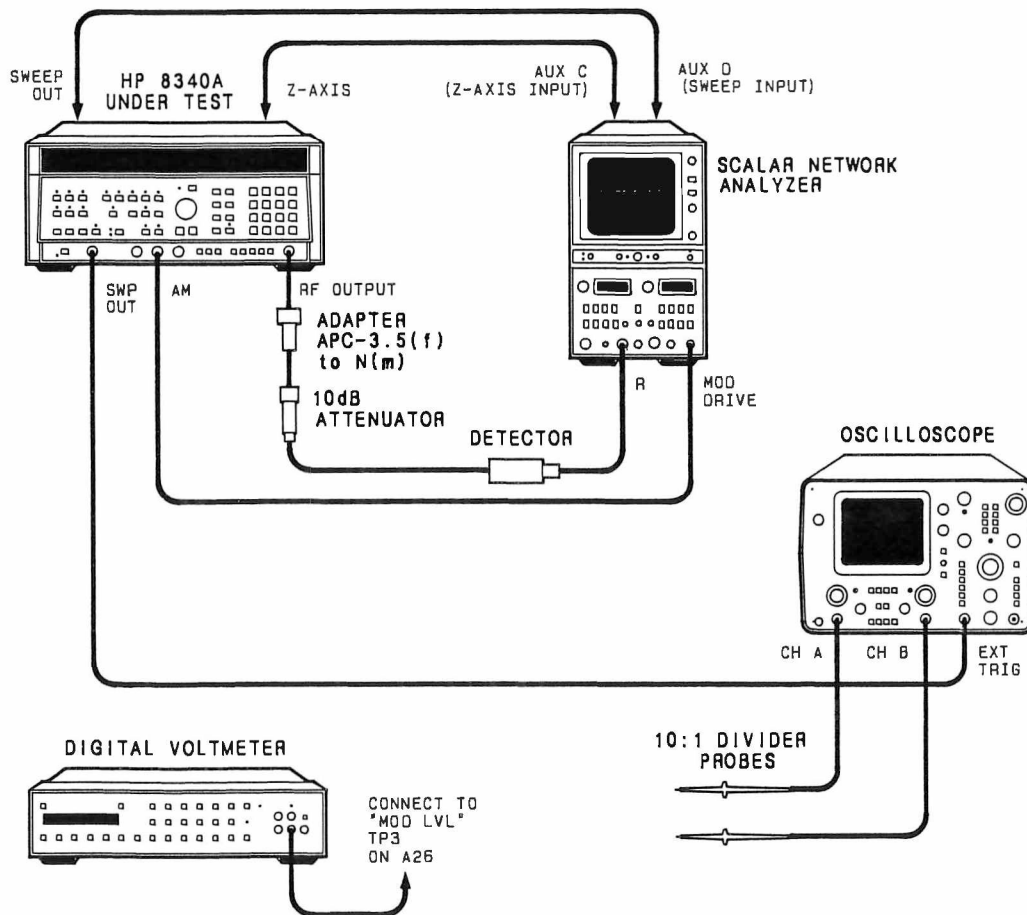

Figure 5-49. Leveled Power SRD Bias Adjustment Test Setup

5-37. LEVELED RF OUTPUT ADJUSTMENTS (Cont'd)**HO2 NOTE**

**THIS PAGE DOES NOT APPLY TO INSTRUMENTS EQUIPPED WITH
OPTION HO2.**

Equipment Required:

Frequency Response Test Set	HP 8755C
Detector	HP 11664B
Oscilloscope	HP 1741A
10:1 Divider Probe (2 Required)	HP 10004D
Digital Voltmeter	HP 3455A
10 dB Attenuator	HP 8493C Option 010

Procedures:**MODULATOR OFFSET**

1. Connect equipment as shown in Figure 5-49. Connect the DVM to A26TP3 (MOD LVL). Preset A26R88 (MO) fully clockwise (Figure 5-50). Allow at least 30 minutes warm up.
2. Press the HP 8340A **[INSTR PRESET]**. Press **[CW]** and enter **[8] [GHz]**. Press **[SHIFT] [METER]** to bypass the ALC circuit and allow direct control of the linear modulator circuit.
3. Adjust the front panel rotary knob for a DVM indication of 0.00 volts, then note the POWER dBm display indication. Adjust A26R88 (MO) CCW to decrease the POWER dBm indication by 0.2 dB.

LEVELED BIAS

4. Disconnect the DVM and connect oscilloscope CHAN A probe to A26TP3 (MOD LVL). Connect CHAN B probe to A24TP12 (SRD).
5. Press HP 8340A **[INSTR PRESET]**. Press **[SHIFT] [CF]** and enter **[2] [0] [0] [MHz]** for a step size of 200 MHz. Press **[SWEEP TIME]** and enter **[5] [0] [msec]**. Press **[SHIFT] [PWR SWP]** to decouple the RF attenuator and ALC, and enter **[−] [2] [0] [dBm]**. Press **[PWR SWP]** and enter **[4] [0] [dB]**. Press **[AM] ON**. Press **[CW]** and enter **[8] [GHz]**. This puts the HP 8340A in power sweep from -20 to $+20$ dB at any frequency selected.

Save this instrument state by pressing **[SAVE] [1]**.

Set A24R1 (OFF A) (Figure 5-50) and A24R2 (OFF B) controls fully counter clockwise.

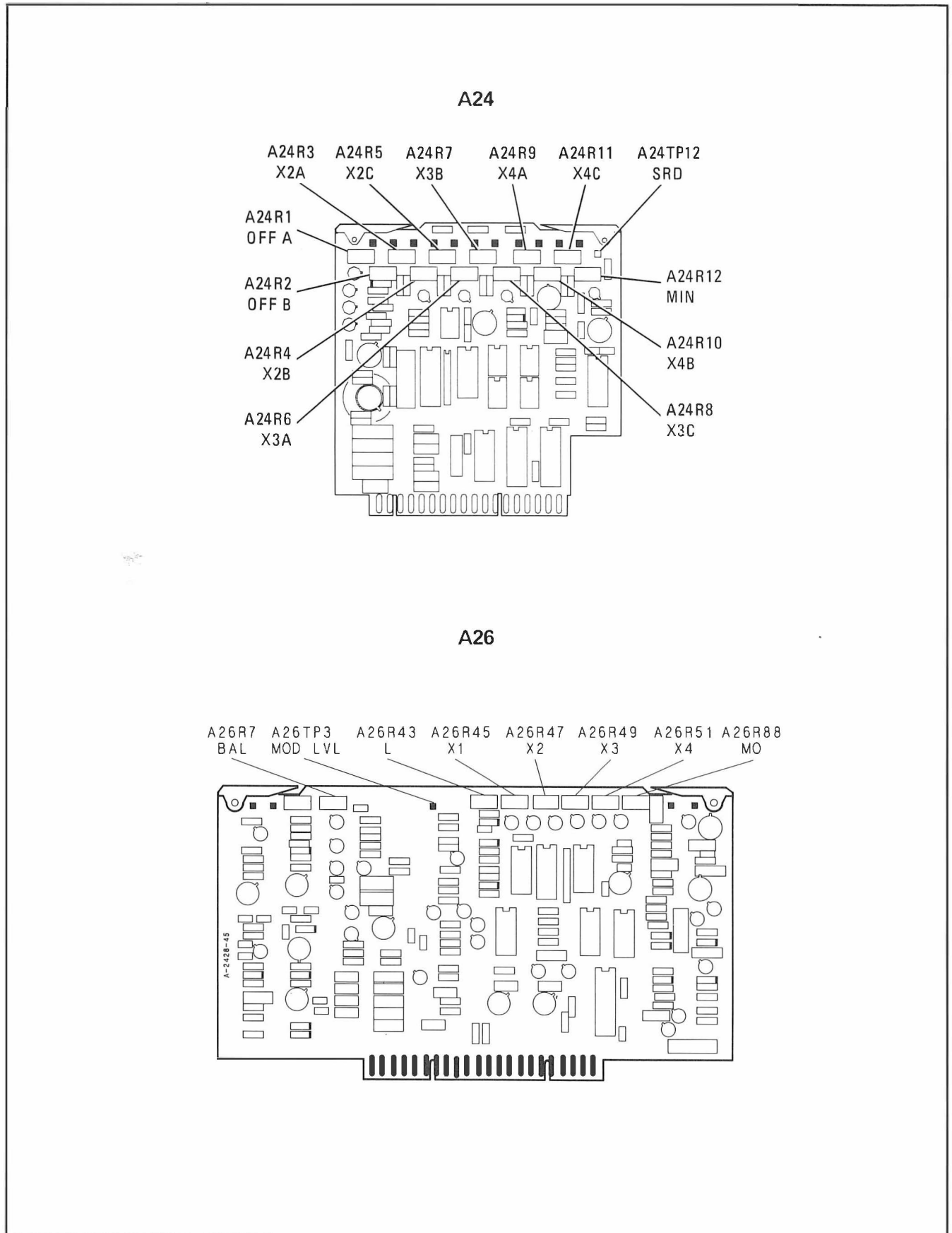

Figure 5-50. SRD Bias Adjustments on A24 and A26

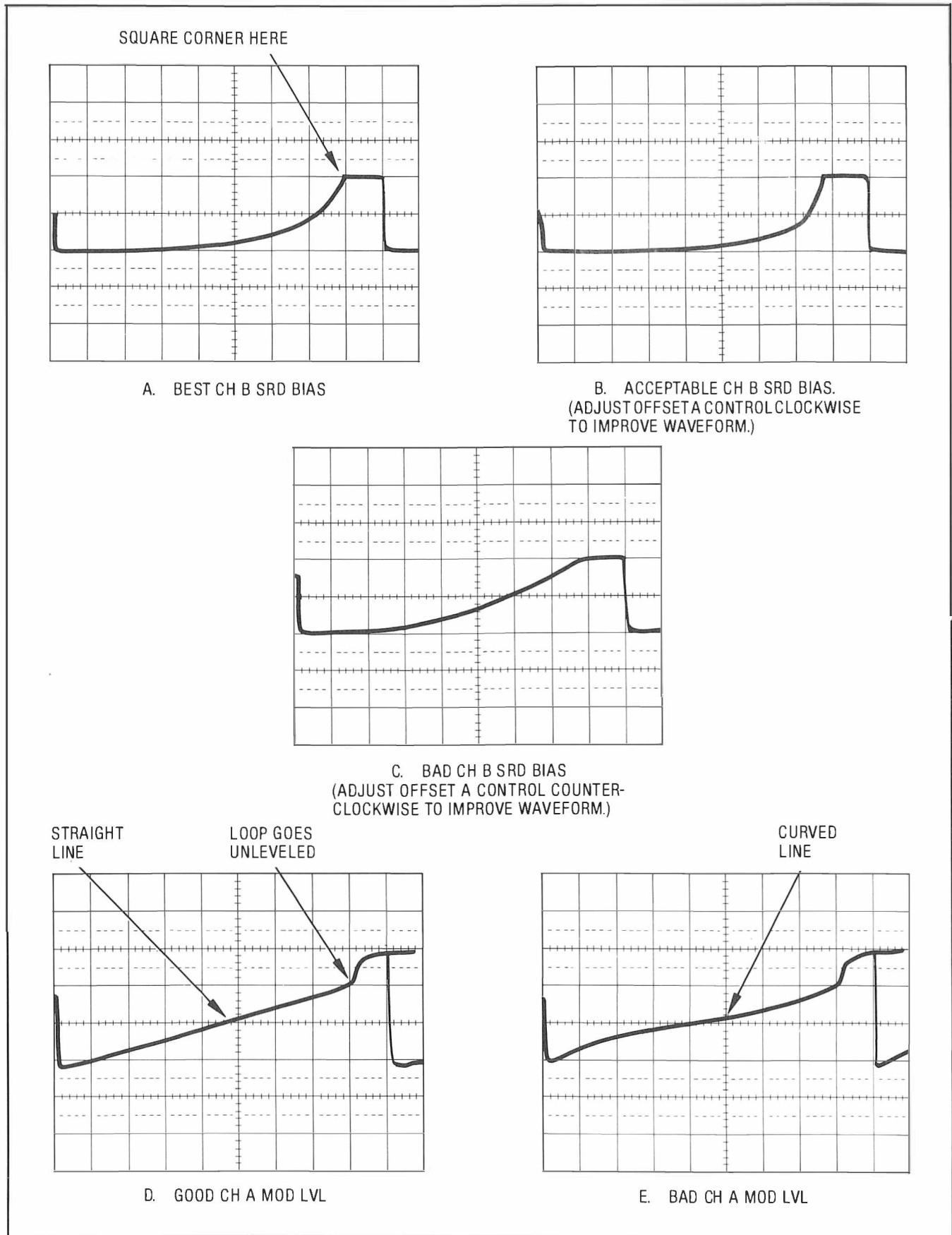

Figure 5-51. Typical MOD LVL and SRD BIAS Waveforms

5-37. LEVELED RF OUTPUT ADJUSTMENTS (Cont'd)

H02 NOTE

THIS PAGE DOES NOT APPLY TO INSTRUMENTS EQUIPPED WITH OPTION H02.

6. Set the oscilloscope as follows:

DISPLAY	CHOP, TRIGGER ON A
CH A	0.05V/Div DC COUPLED
CH B	0.1V/Div DC COUPLED
TRIGGER	EXT. NEG.
TIME/Div	5 ms

The oscilloscope display should look similar to Figure 5-52.

NOTE

It may be necessary to adjust the oscilloscope sweep vernier to view the entire sweep on the CRT.

LEVELED POWER SRD BIAS ADJUSTMENT

7. Center A24R12 MIN control and A24R5 X2C control. Adjust A24R1 OFF A for optimum display as shown in Figure 5-51, Waveform A, B, and C.
8. Press HP 8340A **[CW]** and enter **[1] [0] [.] [6] [GHz]**. Adjust A24R2 OFF B for optimum trace as shown in Figure 5-51, Waveforms A, B, and C. Using the **[STEP]** keys, step through Band 2 from 7 to 13.4 GHz and check for an optimum SRD Bias trace (Figure 5-51, Waveforms D and E) at each step. If not optimum, adjust A24R2 OFF B if the HP 8340A frequency is closer to 13.5 GHz, or adjust A24R1 OFF A if the frequency is closer to 7 GHz. If an adjustment is made, step through the entire band again, making sure every step is optimized or acceptable if all steps cannot be optimized.
9. Set oscilloscope EXT TRIGGER to POS. TRIGGER, DISPLAY A, and set CH A to .02 V/DIV.
10. Press HP 8340A **[INSTR PRESET]**. Press **[START FREQ]** and enter **[7] [GHz]**. Press **[STOP FREQ]** and enter **[1] [3] [.] [5] [GHz]**. Press **[SHIFT] [PWR SWP]** and enter **[-] [2] [0] [dBm]**. Press **[SWEEP TIME]** and enter **[5] [0] [msec]**.
 Save this instrument state by pressing **[SAVE] [2]**.
11. The oscilloscope display should be similar to Figure 5-52. Adjust A24R12 MIN control so that the highest peak on the oscilloscope display is minimum.
12. Press **[RECALL] [1]** then press **[CW]** and enter **[1] [0] [.] [6] [GHz]**. Change oscilloscope EXT TRIGGER to NEG. TRIGGER, DISLAY CHOP: CH A to .05 V/DIV, and CH B to 0.1 V/DIV. Adjust A24R5 X2C to minimize the MOD LEVEL voltage at the start of the power sweep and keep the MOD LEVEL power sweep trace straight with no steps or "bows" as it sweeps up. Using the **[STEP]** keys, step through band 2 from 7 to 13.4 GHz and readjust A24R5 X2C if necessary to improve the MOD LEVEL trace. Also, adjust A24R1 OFF A and A24R2 OFF B if necessary to optimize the SRD Bias as in step 8 above. If any adjustments are made, step through band 2 again until the SRD bias and the MOD LEVEL trace is optimized. It will not be possible to adjust the MOD LEVEL trace for optimum at each step, so adjust for best compromise trace all across Band 2. (See Figure 5-51.)
13. A24R8 X3C and A24R11 X4C are adjusted in Bands 3 and 4 respectively. They are adjusted the same as in Band 2 to minimize the MOD LEVEL voltage at the start of the

5-37. LEVELED RF OUTPUT ADJUSTMENTS (Cont'd)

H02 NOTE

THIS PAGE DOES NOT APPLY TO INSTRUMENTS EQUIPPED WITH OPTION H02.

power sweep and keep the MOD LEVEL trace straight with no “bows” as it sweeps up. (Refer to Figure 5-51.) Press [RECALL] [1] then [CW] and enter [1] [7] [.] [5] [GHz]. Adjust A24R8 X3C for a MOD LEVEL trace as described above. Using the [STEP] keys, step through Band 3 from 13.5 to 19.9 GHz and readjust if necessary to achieve the best MOD LEVEL trace across Band 3.

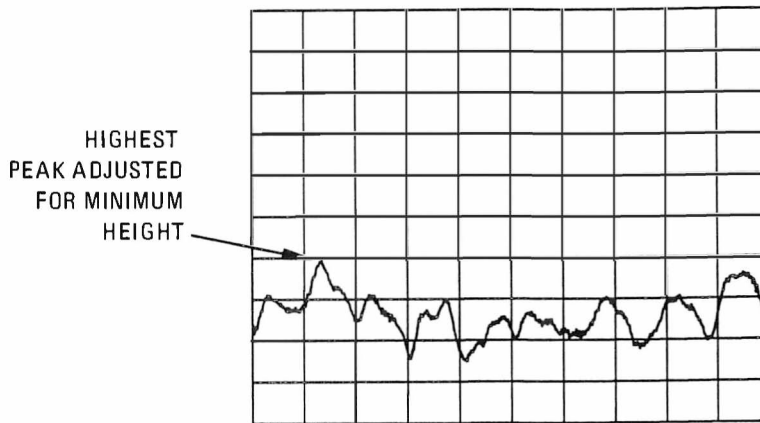

Figure 5-52. Oscilloscope Display at A26TP3 MOD LVL with no Squegging

NOTE

The SRD bias trace is adjusted in Band 2 with A24R1 OFF A and A24R2 OFF B for optimum. It should not require any other adjustments in Bands 3 or 4, unless the SRD bias trace is bad as shown in Figure 5-51. If either the OFF A or OFF B controls are adjusted in Bands 3 or 4, then each band will have to be rechecked, starting with Band 2 at 7 GHz and stepping through each band.

14. Press [RECALL] [1], [CW] [2] [3] [.] [3] [GHz] and adjust A24R11 X4C for a MOD LEVEL trace as described above. Using the [STEP] keys, step through Band 4 from 20.1 to 26.5 GHz and readjust if necessary for best MOD LEVEL trace all across Band 4.
15. Remove oscilloscope probes from the HP 8340A. Connect the HP 8340A to the 8755C as shown in Figure 5-49. Press HP 8340A [INSTR PRESET] and [RECALL] [2]. Press [SHIFT] [PWR SWP] and enter [2] [0] [dBm]. Press [SHIFT] [PULSE]. Press [SWEEP TIME] [AUTO].

Adjust 8755C reference level to view the Band 2 response at 1 dB/DIV. Using the front panel rotary knob and the 8755C reference level controls, vary the ALC level from +20 dBm to -20 dBm. Look for squegging as shown in Figure 5-53. If any squegging occurs, adjust A24R5 X2C counterclockwise to eliminate the squegging.

16. Press [START FREQ] [1] [3] [.] [5] [GHz], [STOP FREQ] [2] [0] [GHz], [SHIFT] [PWR SWP] [2] [0] [dBm]. Vary the ALC level as in step 15 and check for squegging. If squegging occurs, adjust A24R8 X3C counterclockwise to eliminate the squegging.

5-37. LEVELED RF OUTPUT ADJUSTMENTS (Cont'd)

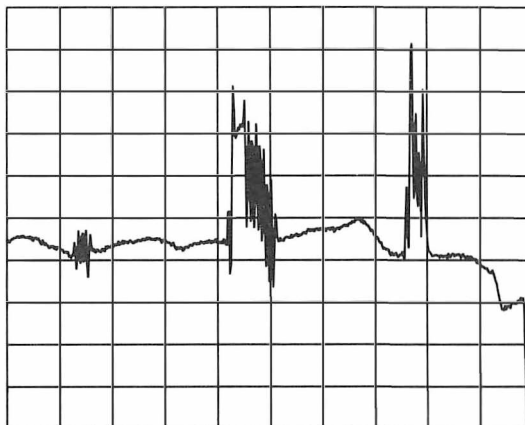

Figure 5-53. 8755C Display with Squegging Present

17. Press **[START FREQ] [2] [0] [GHz]**, **[STOP FREQ] [2] [6] [.] [5] [GHz]**, **[SHIFT] [PWR SWP] [2] [0] [dBm]**. Vary the ALC level as in step 15. If any squegging occurs, adjust A24R11 X4C counterclockwise to eliminate the squegging.
18. Press **[SHIFT] [PWR SWP] [0] [dBm]** and adjust the 8755C REF LEVEL to view Band 4 at 1 dB/DIV. Press **[START FREQ]** and using the front panel rotary knob, move the START FREQ up to 26 GHz and down to 14 GHz while watching the 8755C display for squegging. If any squegging is seen, stop at the START FREQ where it occurs. If the squegging occurs in Band 3 (13.5 to 20 GHz), adjust A24R8 X3C counterclockwise until squegging is gone. If squegging occurs in Band 4 (20 to 26.5 GHz), adjust A24R11 X4C counterclockwise until the squegging is gone. Press **[SHIFT] [PWR SWP] [-] [5] [dBm]** and change the start frequency as above; adjust out squegging if any occurs. Press **[SHIFT] [PWR SWP] [-] [1] [0] [dBm]** and change the start frequency as above; adjust out squegging if any occurs. Press **[SHIFT] [PWR SWP] [-] [1] [5] [dBm]** and change the start frequency as above; adjust out squegging if it occurs.

LINEAR MODULATOR ALC LOOP GAIN ADJUSTMENTS

Description:

The following adjustments are performed to set the ALC Loop Gain for each band. The adjustment is done in the power sweep (PWR SWP) mode, while sweeping the ALC Loop from -20 dBm to maximum power (or +20 dBm).

NOTE

If the A26 Assembly has not been replaced, adjustments may not be necessary.

19. Connect the 8340A SWEEP OUT to the oscilloscope EXT TRIGGER. Connect CH A probe to A26TP3 (MOD LVL). Connect CH B probe to A25TP2 (DET). Set up the oscilloscope as follows:

5-37. LEVELED RF OUTPUT ADJUSTMENTS (Cont'd)

DISPLAY..... CHOP
 CH A..... 0.05V/Div DC COUPLED
 CH B..... 0.05V/Div DC COUPLED
 TRIGGER..... EXT NEG
 TIME/Div..... 5 ms
 SWEEP VERNIER..... ON

20. Press the 8340A [INSTR PRESET]. Press [SWEEP TIME] and enter [5] [0] [msec]. Press [SHIFT] [PWR SWP] and enter [-] [2] [0] [dBm]. Press [PWR SWP] and enter [4] [0] [dBm]. Press [SHIFT] [CF] [2] [0] [0] [MHz]. Press [AM] to turn it ON. Press [CW] and enter [1] [0] [MHz].

The oscilloscope display should be similar to Figure 5-54, Waveforms A and B. It may be necessary to adjust the SWEEP VERNIER to view the entire power sweep.

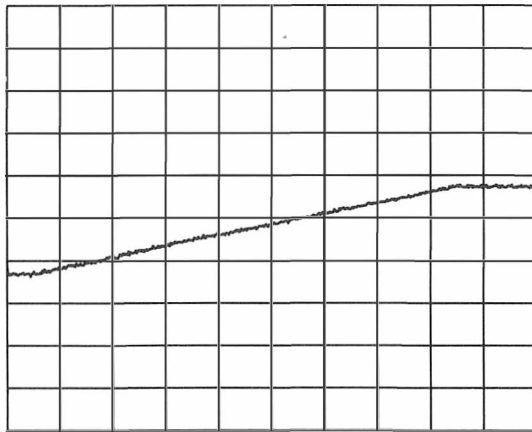

A. TYPICAL DET WAVEFORM

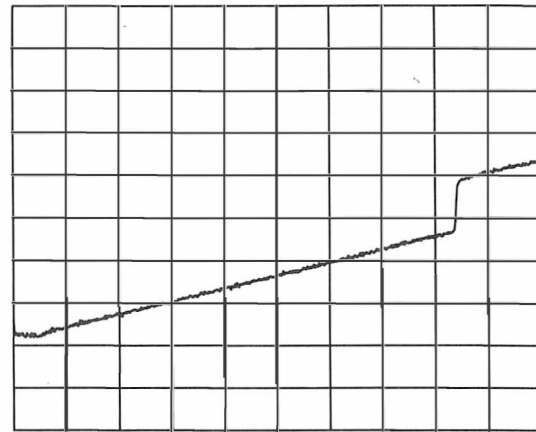

B. TYPICAL MOD LVL WAVEFORM

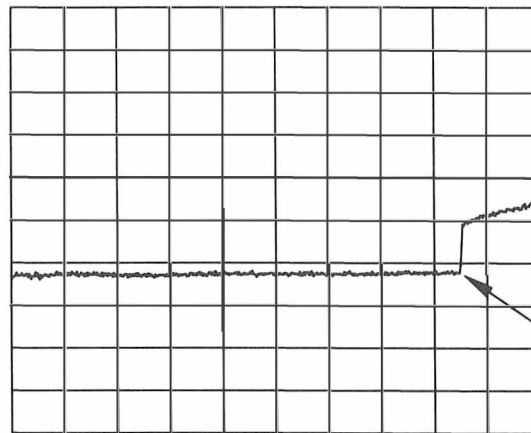

C. TYPICAL MOD LVL MINUS DET WAVEFORM

Figure 5-54. Typical MOD LVL and DET Waveforms for ALC Loop Gain Adjustment

5-37. LEVELED RF OUTPUT ADJUSTMENTS (Cont'd)**NOTE**

In step 21 through 25, the oscilloscope display will be adjusted for the most horizontal line. This adjustment is only concerned with the trace up to where it deviates from a flat line. (See Figure 5-54, waveform C.) This point on the display will change position with frequency.

21. On the oscilloscope, invert Channel B and select DISPLAY A+B mode. Using the 8340A [STEP] keys, step the CW frequency through Band 0 from 10 MHz to 2.21 GHz and adjust A26R43 HET for the most horizontal line across Band 0.
22. Press [CW] and enter [2] [.] [3] [GHz]. Using the [STEP] keys, step the CW frequency through Band 1 from 2.3 to 6.9 GHz and adjust A26R45 X1 for the most horizontal line across Band 1.
23. Press [CW] and enter [7] [GHz]. Using the [STEP] keys, step the CW frequency through Band 2 from 7.0 to 13.4 GHz and adjust A26R47 X2 for the most horizontal line across Band 2.
24. Press [CW] and enter [1] [3] [.] [5] [GHz]. Using the [STEP] keys, step the CW frequency through Band 3 from 13.5 to 19.9 GHz and adjust A26R49 X3 for the most horizontal line across Band 3.
25. Press [CW] and enter [2] [0] [GHz]. Using the [STEP] keys, step the CW frequency through Band 4 and adjust A26R51 X4 for the most horizontal line across Band 4.

NOTE

A26R7 BAL is adjusted in the Pulse Adjustment procedure and A26R88 MO is adjusted in the Leveled Power SRD Bias Adjustment procedure.

SYTM TRACKING USING AUTO TRACK**Description:**

Auto Tracking is an internal program that sets Calibration Constants 9 through 12 and 50 through 53 to optimize the tracking. The program takes about 5 to 10 seconds to run and is invoked using [SHIFT] [PEAK].

When [SHIFT] [PEAK] is pressed, the HP 8340A adjusts the Calibration Constants to give tracked performance. The tracking adjustments made to the A28 SYTM Driver should be adjusted in connection with the auto-tracking routine to give optimum tracking performance.

5-37. LEVELED RF OUTPUT ADJUSTMENTS (Cont'd)

Equipment Required:

Frequency Response Test Set	HP 8755C
Detector	HP 11664B
Storage Normalizer	HP 8750A
Oscilloscope	HP 1741A
10:1 Divider Probe	HP 10004D
Digital Voltmeter	HP 3455A
Power Meter	HP 436A
Power Sensor	HP 8485A
10 dB Attenuator	HP 8493C Option 010

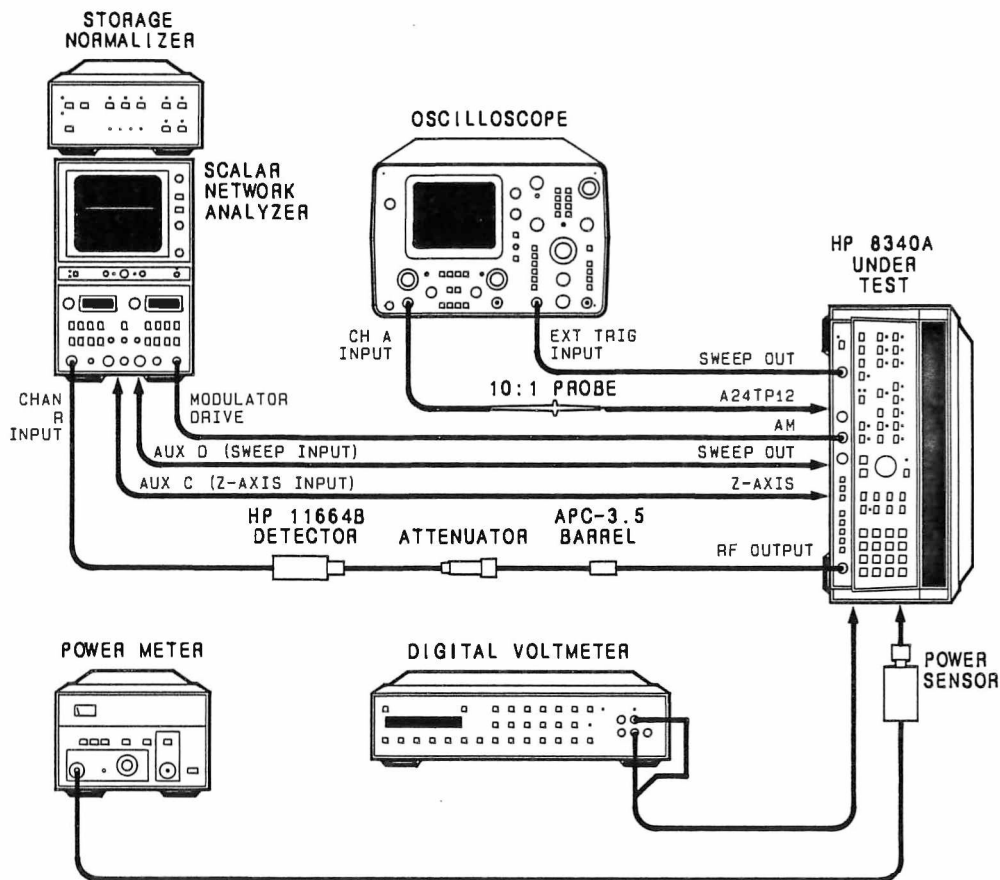

Figure 5-55. SYTM Tracking and Delay, and Leveled SRD Bias Adjustment Setup

26. Connect equipment for SYTM tracking as shown in Figure 5-55. Allow at least 30 minutes warm up.
27. Press HP 8340A [INSTR PRESET] then press [SHIFT] [PULSE]. Press [START FREQ] and enter [6] [.] [9] [GHz]. Press [STOP FREQ] and enter [1] [3] [.] [5] [GHz]. Press [SWEEP TIME] and enter [2] [0] [0] [msec]. Press [XTAL] leveling key to obtain non-leveled operation. Display CH R on both channels at 1 dB/Div so that one channel can be stored and then compared to the other channel. Store the Band 2 response using the storage normalizer by pressing 8750A CH1 INPUT, STORE INPUT, and RECALL.

5-37. LEVELED RF OUTPUT ADJUSTMENTS (Cont'd)

28. Press **[SHIFT] [PEAK]**. After about 10 seconds, the CH 2 trace should match the stored CH 1 trace within approximately 0.5 dB. If the difference is less than 1 dB, proceed to step 33, otherwise continue with step 29.
29. Adjust the low end of Band 2 with A28R1 OFF and the high end with the auto track routine (**[SHIFT] [PEAK]**) until the unlevelled power trace for Band 2 is optimized.
30. Store the optimized trace using the storage normalizer as described in step 27.
31. Set Calibration Constant Number 10 to 1024 as follows. Press **[SHIFT] [GHz] [1] [0] [Hz] [SHIFT] [MHz] [1] [2] [Hz] [SHIFT] [kHz] [2] [2] [Hz]** and enter **[1] [0] [2] [4] [Hz]**.
32. Adjust A28R8 GAIN until the trace on the 8755C matches the stored trace. Go to step 28 and repeat auto-track routine until no further adjustments are necessary.
33. For Band 1, press **[START FREQ]** and enter **[2] [.] [3] [GHz]**. Press **[STOP FREQ]** and enter **[7] [GHz]**.
34. Adjust the low end of Band 1 with A28R113 B1 OFF and the high end of Band 1 with Calibration Constant Number 9. Calibration Constant Number 9 may be accessed as follows. Press **[SHIFT] [GHz] [9] [Hz] [SHIFT] [MHz] [1] [2] [Hz] [SHIFT] [kHz] [2] [2] [Hz]**. Use the rotary knob to optimize the high end. Adjust both A28R113 B1 OFF and Calibration Constant Number 9 until the optimum trace is present on the 8755C. Do not worry about sections that drop out due to squegging; they will not present a problem with leveled output power over the specified power range of the instrument.
35. Store the optimized trace using the storage normalizer as described in step 27. Press **[ENTRY OFF]** to disable the rotary knob.
36. Press **[SHIFT] [PEAK]** and wait until the auto tracking is complete. If the resulting trace is greater than 1 dB from the stored trace, adjust A28R113 B1 OFF and repeat this step until the trace is within 1 dB of the stored trace.
37. For Band 3, press **[START FREQ]** and enter **[1] [3] [.] [3] [5] [GHz]**. Press **[STOP FREQ]** and enter **[2] [0] [GHz]**.
38. Adjust the low end of Band 3 with Calibration Constant Number 11. Calibration Constant Number 11 may be accessed by pressing **[SHIFT] [GHz] [1] [1] [Hz] [SHIFT] [MHz] [1] [2] [Hz] [SHIFT] [kHz] [2] [2] [Hz]**. Adjust the high end of Band 3 with A28R2 B1. Iterate adjusting the low end and the high end until the optimum trace is present on the 8755C.
39. Store the optimized trace using the storage normalizer as described in step 27. Press **[ENTRY OFF]** to disable the rotary knob.
40. Press **[SHIFT] [PEAK]** and wait until the auto tracking is complete. If the resulting trace is greater than 1 dB from the stored trace, adjust A28R2 B1. Repeat this step until the trace is within 1 dB of the stored trace.
41. For Band 4, press **[START FREQ]** and enter **[1] [9] [.] [8] [GHz]**. Press **[STOP FREQ]** and enter **[2] [6] [.] [5] [GHz]**.

5-37. LEVELED RF OUTPUT ADJUSTMENTS (Cont'd)

42. Adjust the low end of Band 4 with Calibration Constant Number 12. Calibration Constant Number 12 may be accessed as follows. Press **[SHIFT] [GHz] [1] [2] [Hz] [SHIFT] [MHz] [1] [2] [Hz] [SHIFT] [KHz] [2] [2] [Hz]**. Adjust the middle of Band 4 using A28R3 BP2. Adjust the high end of Band 4 using A28R4 BP3 and A28R5 BP3FRQ. Iterate all of these adjustments until the optimum trace is present on the 8755C.
43. Store the optimized trace using the storage normalizer as described in step 27. Press **[ENTRY OFF]** to disable the rotary knob.
44. Press **[SHIFT] [PEAK]** and wait until the auto tracking is complete. If the trace is greater than 1 dB from the stored trace, iterate the adjustments using autotracking (**[SHIFT] [PEAK]**), A28R3 BP2, A28R4 BP3, and A28R5 BP3FRQ until the trace is within 1 dB of the stored trace.
45. Press **[SHIFT] [MHz] [1] [4] [Hz] [SHIFT] [KHz] [5] [3] [4] [9] [Hz] [INSTR PRESET]** to copy the new Calibration Constant values permanently in "protected memory area".

LEVELED SQUEGGING TEST USING THE 8566A SPECTRUM ANALYZER**Description:**

The 8340A Under Test RF output signal is down converted using a Local Oscillator 8340A and a mixer. The IF output of the mixer is fed to a spectrum analyzer. Any squegging of the 8340A under test will appear as a spurious response on the IF signal.

This test should be performed after SYTM tracking and delay, and SRD unlevelled bias adjustments.

Equipment Required:

Synthesized Sweeper	HP 8340A (Opt 001)
10 dB Attenuator	HP 8493C Option 010
Mixer	RHG DMS 1-26
Spectrum Analyzer.....	HP 8566A

46. Connect equipment as shown in Figure 5-56. Connect the mixer LO input port directly to the LO 8340A RF output connector to obtain maximum mixer LO input level. Allow at least 30 minutes warm up time.
47. Press the LO 8340A **[INSTR PRESET]**. Press **[START FREQ]** and enter **[6] [.] [4] [GHz]**. Press **[STOP FREQ]** and enter **[1] [2] [.] [9] [GHz]**. Press **[POWER LEVEL]** and enter **[1] [0] [dBm]**. Press **[SHIFT] [CF]** and enter **[1] [0] [0] [MHz]** for a step size of 100 MHz. Press **[MANUAL] SWEEP** and enter **[6] [.] [4] [GHz]** to set the LO to CW at 6.4 GHz.
48. Press the 8340A Under Test **[INSTR PRESET]**. Press **[START FREQ]** and enter **[7] [GHz]**. Press **[STOP FREQ]** and enter **[1] [3] [.] [5] [GHz]**. Press **[POWER LEVEL]** and using the front panel rotary knob, adjust for maximum leveled power (just before the UNLEVELED light comes on). Press **[SHIFT] [CF]** and enter **[1] [0] [0] [MHz]** for a step size of 100 MHz. Press **[MANUAL] SWEEP** and enter **[7] [GHz]**. The mixer IF frequency is now 600 MHz.

5-37. LEVELED RF OUTPUT ADJUSTMENTS (Cont'd)

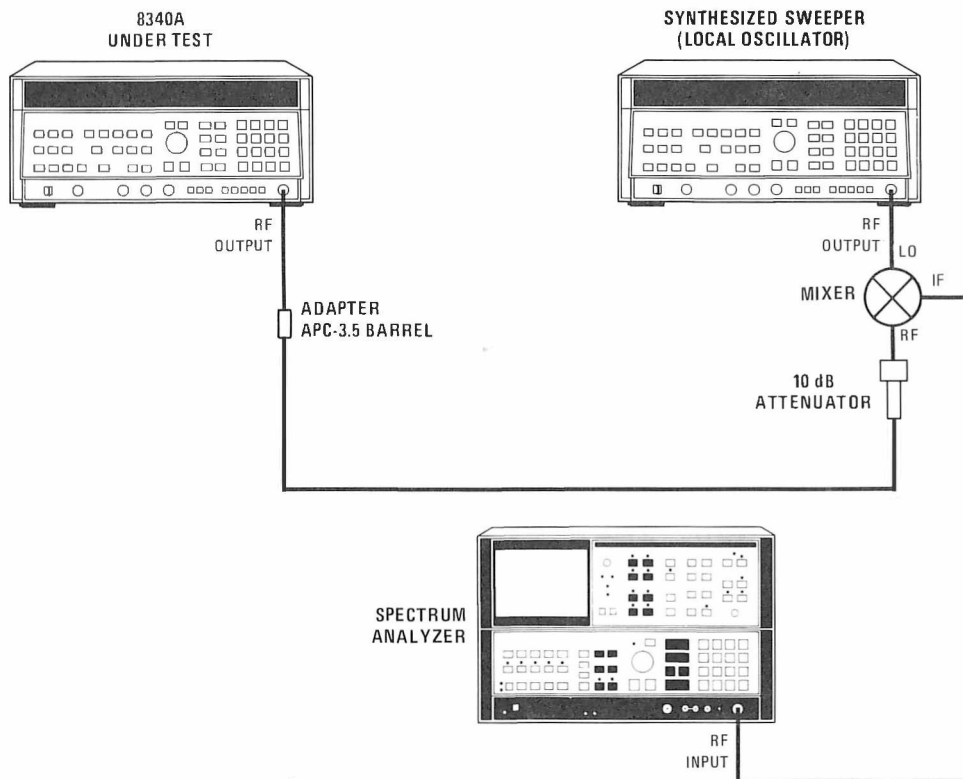

Figure 5-56. Leveled Squegging Test Setup.

49. Set the spectrum analyzer for FULL SPAN of 0-2.5 GHz. Set RES BW for 300 kHz. Set VIDEO BW for 100 kHz. Set START FREQ to 590 MHz. Set STOP FREQ to 800 MHz. Set REFERENCE LEVEL to -10 dBm. Set ATTN to 0 dB. Press HOLD to retain these settings. The 600 MHz IF signal should be near the left side of the spectrum analyzer CRT.
50. Using the STEP UP key on both the 8340A Under Test and the LO 8340A, step through Band 2 observing the spectrum analyzer display at each step. There may be responses due to mixing products. These will appear as low level signals. A squegging response will appear as a higher amplitude signal as shown in Figure 5-57. If squegging occurs, adjust A24R5 (X2C) slightly CCW to eliminate the squegging. Note, if the control is adjusted and there is no effect on the response, the response is probably a mixing product.

NOTE

Test for squegging at power levels from maximum leveled power to -20 dBm in 5 dB increments.

51. Press 8340A Under Test [SHIFT] [PWR SWP] and enter the maximum ALC power level that will be a 5 dB increment below max leveled power (i.e., 15, 10, 5). Repeat step 50 at this power level. Enter the next 5 dB increment and repeat step 50 until the test for squegging has been performed from maximum leveled power to -20 dBm.

5-37. LEVELED RF OUTPUT ADJUSTMENTS (Cont'd)

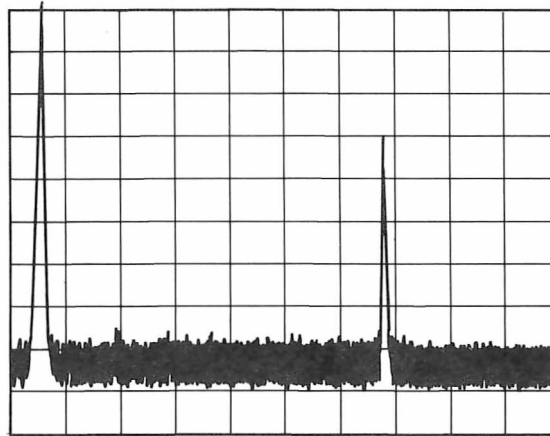

Figure 5-57. Squegging Displayed on Spectrum Analyzer

52. For Band 3, press the LO 8340A **[START FREQ]** and enter **[1] [2] [.] [9] [GHz]**. Press **[STOP FREQ]** and enter **[1] [9] [.] [4] [GHz]**. Press **[MANUAL]** and enter **[1] [2] [.] [9] [GHz]**.
53. Press the 8340A Under Test **[START FREQ]** and enter **[1] [3] [.] [5] [GHz]**. Press **[STOP FREQ]** and enter **[2] [0] [GHz]**. Press **[POWER LEVEL]** and using the front panel rotary knob, adjust for maximum leveled power. Press **[MANUAL]** and enter **[1] [3] [.] [5] [GHz]**.
54. Using the step keys as described in step 50, step through Band 3. If squegging occurs, adjust A24R8 (X3C) slightly CCW to eliminate the squegging.

NOTE

Test for squegging at power levels from maximum leveled power to -20 dBm in 5 dB increments.

55. Press 8340A Under Test **[SHIFT] [PWR SWP]** and enter the maximum ALC power level that will be a 5 dB increment below max leveled power (i.e., 10, 5). Repeat step 54 at this power level. Enter the next 5 dB increment and repeat step 54 until the test for squegging has been performed from maximum leveled power to -20 dBm.
56. For Band 4, press the LO **[START FREQ]** and enter **[1] [9] [.] [4] [GHz]**. Press **[STOP FREQ]** and enter **[2] [5] [.] [9] [GHz]**. Press **[MANUAL]** and enter **[1] [9] [.] [4] [GHz]**.
57. Press the 8340A Under Test **[START FREQ]** and enter **[2] [0] [GHz]**. Press **[STOP FREQ]** and enter **[2] [6] [.] [5] [GHz]**. Press **[CONT]** and **[POWER LEVEL]**. Adjust the 8340A front panel rotary knob for maximum leveled power. Press **[MANUAL]** and enter **[2] [0] [GHz]**.
58. Using the step keys as described in step 50, step through Band 4. If squegging occurs, adjust A24R11 (X4C) slightly CCW to eliminate the squegging.

5-37. LEVELED RF OUTPUT ADJUSTMENTS (Cont'd)**NOTE**

Test for squegging at power levels from maximum leveled power to -20 dBm in 5 dB increments.

59. Press 8340A Under Test [**SHIFT**] [**PWR SWP**] and enter the maximum ALC power level that will be a 5 dB increment below max leveled power (i.e., 5, 0, -5). Repeat step 58 at this power level. Enter the next 5 dB increment and repeat step 58 until the test for squegging has been performed from maximum leveled power to -20 dBm.

5-38. FLATNESS VERIFICATION AND ADJUSTMENT

Reference:

Performance Test: Maximum Leveled Output Power and Accuracy
Service Section: RF Section

Description:

This procedure tests the 8340A for leveled power flatness. If the 8340A meets the requirements in this procedure, flatness adjustments are not necessary. Flatness is checked in the 10 MHz to 2.4 GHz band by finding the minimum and maximum power points across the frequency band using an oscilloscope to view the power meter recorder output while sweeping. A marker is positioned at the minimum and maximum points. The 8340A is set to Manual Sweep at the marker frequencies and the power is measured. Flatness is the maximum deviation from the power level at 100 MHz for the 0.01 to 2.4 GHz range and at 2.4 GHz for the 2.4 to 26.5 GHz range. Flatness corrections are made by modifying the Calibration Constants data.

In the 2.4 to 26.5 GHz bands, an 8755C Frequency Response Test Set and directional coupler are used to display the swept frequency signal. Errors due to frequency response of the test equipment are subtracted from the measurement by the Storage Normalizer.

NOTE

If equipment and the program are available to run the automated test on flatness described in manual supplement titled "Automated Test Procedures", it may be used instead of these procedures in Paragraph 5-38.

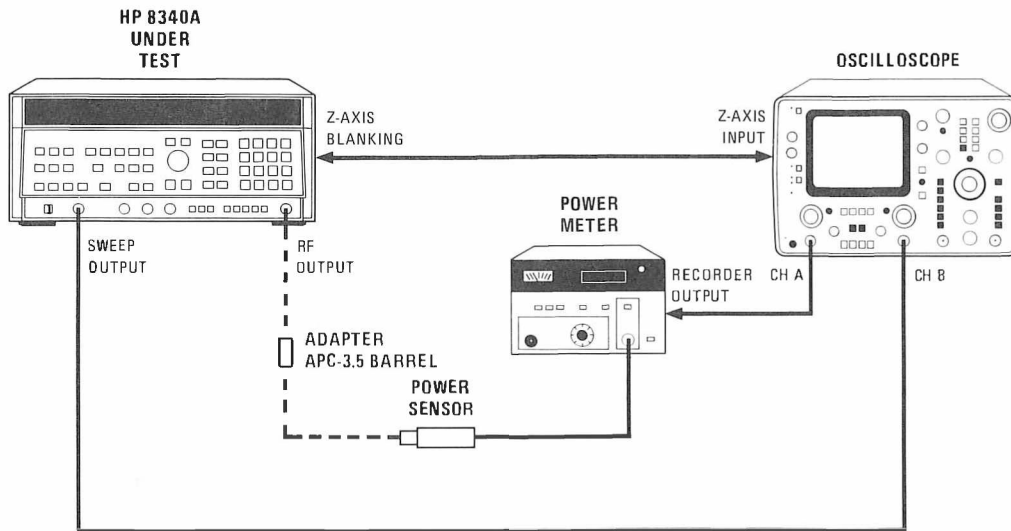

Figure 5-58. Flatness Verification Test Setup

Equipment Required:

- Oscilloscope..... HP 1741A
- Power Meter..... HP 436A
- Power Sensor..... HP 8481A
- Power Sensor..... HP 8485A
- Adapter (APC-3.5 fem. to fem.) HP Part Number 5061-5311

5-38. FLATNESS VERIFICATION AND ADJUSTMENT (Cont'd)**HO2 NOTE**

THIS PAGE DOES NOT APPLY TO INSTRUMENTS EQUIPPED WITH OPTION HO2.

Procedure:

10 MHz to 2.4 GHz FLATNESS VERIFICATION

1. Connect the equipment as shown in Figure 5-58. Connect the HP 8485A Power Sensor to the power meter. Allow at least 30 minutes warm up time. Set the power meter calibration factor switch for 2.4 GHz, then zero and calibrate the power meter before connecting the power sensor to the HP 8340A Under Test.
2. Press HP 8340A **[INSTR PRESET]**. Press the **[STOP FREQ]** key and enter **[2] [.] [4] [GHz]**. Adjust oscilloscope horizontal position and gain to obtain a full CRT horizontal trace.
3. Press the **[SWEEP TIME]** key and enter an appropriate sweep time (for an oscilloscope, enter 2 to 5 seconds dependent upon CRT illumination).
4. Adjust the oscilloscope controls to view the power meter **RECORDER OUTPUT** voltage versus the HP 8340A **SWEEP OUTPUT** voltage (A versus B). The oscilloscope vertical gain and position must be changed as a function of the power meter range and **RECORDER OUTPUT** voltage.
5. Press Frequency Marker key **[M2]** and, using the rotary knob, vary the marker frequency to position the (intensified) marker on the lowest point on the oscilloscope trace. It may be necessary to adjust the oscilloscope **INTENSITY** to view the marker dot.
6. Note the marker frequency. Press the **[MANUAL]** key and enter the frequency noted for M2. Set the power meter calibration factor switch for this frequency. The power meter indication is the minimum power point. Record this power meter indication.

NOTE

If the minimum or maximum power occurred below 50 MHz, use the 8481A Power Sensor to measure the power level.

7. Press the **[CONT]** key to return to the power sweep mode. Press **[M1]** and, using the rotary knob, vary the marker frequency to position the marker on the highest point on the oscilloscope trace. Note the marker frequency. Press the **[MANUAL]** key and enter the frequency noted for M1. Set the power meter calibration factor switch for this frequency. The power meter indication is the maximum power point. Record the power meter indication.
8. Press **[M3]** and enter **[1] [0] [0] [MHz]**. Set the power meter calibration factor for 100 MHz. The power meter indication is the power level at 100 MHz used for reference in the remainder of this test. Record the indication.
9. Calculate the power flatness by comparing the minimum power point (step 6) and the maximum power point (step 7) against the 100 MHz reference (step 8). To meet the specification in the 10 MHz to 2.4 GHz band (Band 0), the power meter indications relative to the 100 MHz reference power level should be within ± 0.5 dB in a standard instrument and within ± 0.6 dB in an Option 004 or 006 instrument. If the flatness specification is not met, proceed to step 24 and make power flatness adjustments.

5-38. FLATNESS VERIFICATION AND ADJUSTMENT (Cont'd)

H02 NOTE

THIS PAGE DOES NOT APPLY TO INSTRUMENTS EQUIPPED WITH OPTION H02.

2.4 to 26.5 GHz FLATNESS

Calculate Total Coupler Slope and Sensor Slope

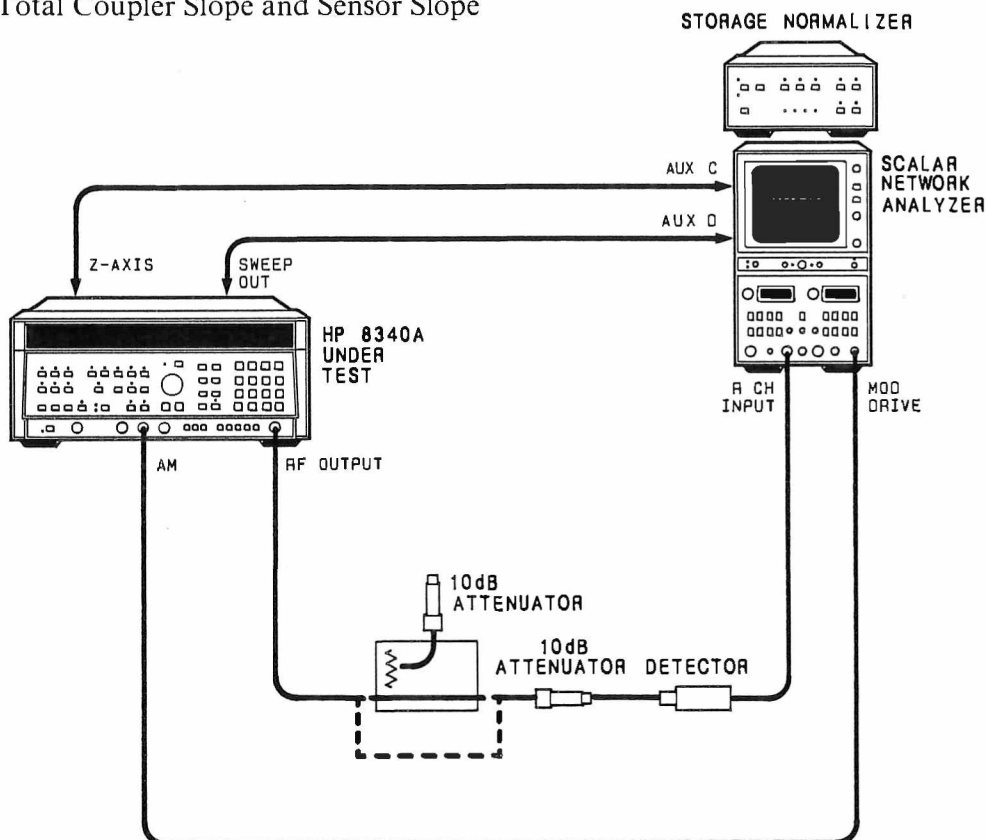

Figure 5-59. Coupler Slope Characterization Test Setup

Equipment Required:

Frequency Response Test Set	HP 8755C
Detector	HP 11664B
Storage Normalizer	HP 8750A
10 dB Attenuator (2 required)	HP 8493C Opt. 010
Directional Coupler	HP Part Number 0955-0125

10. Connect equipment as shown in Figure 5-59. Connect 10 dB Attenuator and 11664B Detector directly to HP 8340A RF Output. Allow at least 30 minutes warm up. Press HP 8340A [INSTR PRESET]. Press [START FREQ] and enter [2] [.] [4] [GHz]. Stop frequency should be 26.5 GHz. Press [SHIFT] [PULSE].
11. Set the 8755C input to channel R, center the trace at 1 dB/Div. Store this trace in the HP 8750A Storage Normalizer by pressing 8750A [CH1] [INPUT], [STORE INPUT].
12. Insert the directional coupler and the second 10 dB attenuator as shown in Figure 5-59. Press 8750A [INPUT - MEMORY]. Press HP 8340A [SLOPE] ON. Adjust the HP 8340A front panel rotary knob for the best straight line on the 8755C trace. Note the HP 8340A ENTRY DISPLAY value for slope. This is the correction factor for the coupler which will be used in subsequent steps.

5-38. FLATNESS VERIFICATION AND ADJUSTMENT (Cont'd)

H02 NOTE

THIS PAGE DOES NOT APPLY TO INSTRUMENTS EQUIPPED WITH OPTION H02.

13. Calculate a correction factor for the power sensor as follows:

Use a calculator to find the best straight line approximation to the CAL FACTOR curve in percent, or find the end points (0.05 and 26.5 GHz) using a straight edge for the best straight line approximation on the CAL FACTOR curve located on the body of the power sensor.

Convert both end points to dB using the following equation:

$$\text{Endpoint (dB)} = -10 \log (\text{endpoint (\%)/100})$$

Calculate the slope as follows:

$$\text{Slope (dB/GHz)} = [26.5 \text{ GHz endpoint (dB)} - 0.05 \text{ GHz endpoint (dB)}] / 26.45$$

14. Calculate the total correction value by adding the coupler correction factor from step 12 and the power sensor correction factor from step 13. Note this value for later use.

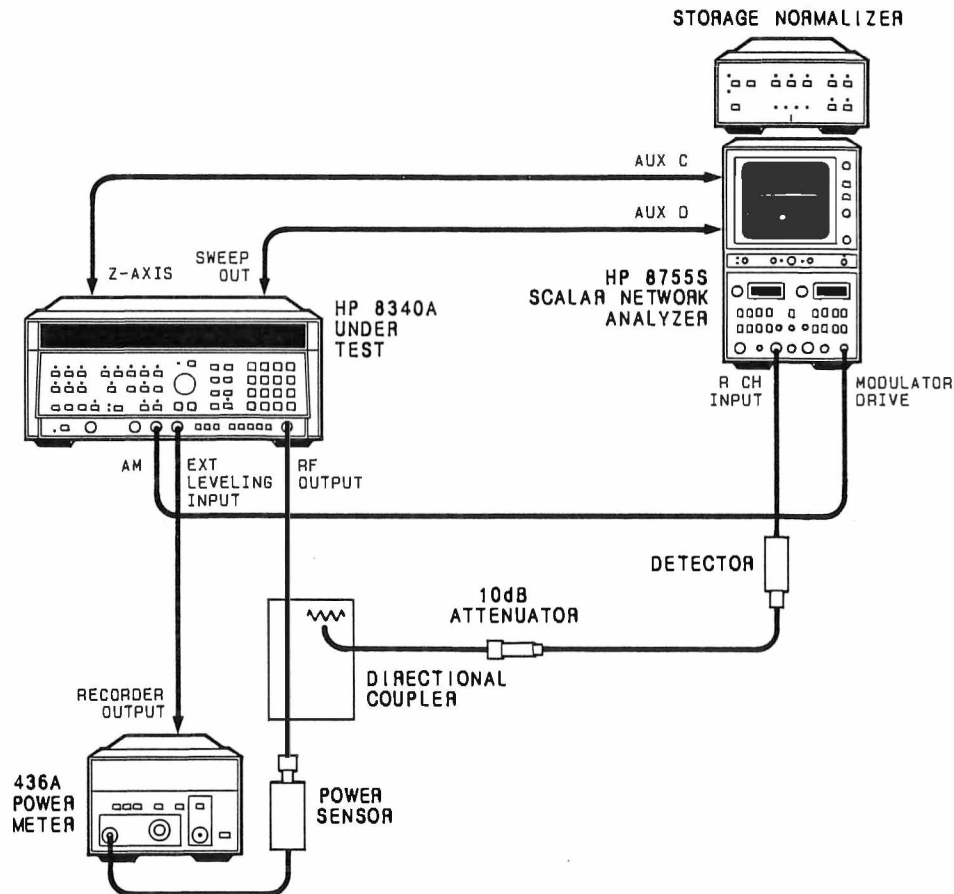

Figure 5-60. Flatness Adjustment Equipment Test Setup

15. Connect the equipment as shown in Figure 5-60. Press HP 8340A [CW] and enter [5][GHz]. Press [RF] to turn RF power off. Zero the power meter. Press [RF] to turn RF power on. The power level should be 0 dBm. Press the 436A [RANGE HOLD].
16. Press HP 8340A [CONT]. Set the 8755C to display R on channel 1 at 1 dB/DIV. Set reference level at about -27 dB to center the trace. Press HP 8340A [METER] leveling and enter [-][6][dBm] (dBV). Press [SWEEP TIME] and enter [5][0][sec].

5-38. FLATNESS VERIFICATION AND ADJUSTMENT (Cont'd)**HO2 NOTE**

THIS PAGE DOES NOT APPLY TO INSTRUMENTS EQUIPPED WITH OPTION HO2.

17. Press 8750A [CHI] [INPUT] and [STORE INPUT]. Press HP 8340A [**SINGLE**] SWEEP and verify that the HP 8340A is sweeping by watching the green SWEEP LED. At the end of the 50 second single sweep, the 8750A STORE LED should be ON. Press HP 8340A [**SINGLE**] SWEEP again and the 8750A STORE INPUT LED should go OFF. The reference trace is now stored in the 8750A.
18. Press HP 8340A [**SWEEP TIME**] and [**AUTO**]. Press [**INT**] LEVELING. Press [**SHIFT**] [**PWR SWP**] and enter [**0**] [**dBm**]. Press [**CONT**] SWEEP. Press [**SLOPE**] and enter the calculated correction value for the directional coupler and power sensor noted in step 14. Terminate the entry with [**dBm**].
19. Press 8750A [INPUT – MEMORY]. The trace on the 8755C should be only the flatness of the HP 8340A in internal leveling mode.
20. Press Frequency Marker key [**M1**] and, using the rotary knob, vary the marker frequency to position the intensified marker to the following positions and note the frequency of each:
 - a. Highest spot in 2.4 to 20 GHz range
 - b. Second highest spot in 2.4 to 20 GHz range
 - c. Lowest spot in 2.4 to 20 GHz range
 - d. Second lowest spot in 2.4 to 20 GHz range
 - e. Highest spot in 20 to 26.5 GHz range
 - f. Second highest spot in 20 to 26.5 GHz range
 - g. Lowest spot in 20 to 26.5 GHz range
 - h. Second lowest spot in 20 to 26.5 GHz range.
21. Disconnect directional coupler from HP 8340A RF OUTPUT port and connect the HP 8485 Power Sensor directly to the RF OUTPUT port.
22. Press to release HP 8340A [**SLOPE**] to turn slope OFF. Verify that [**INT**] leveling switch is still on. Press [**MANUAL**] Sweep, set frequency, and make power meter measurements at 2.4 GHz then at each of the frequencies noted for peaks and valleys in step 20. Before making each measurement, be sure to set the calibration factor of the power meter to the value shown on the body of the power sensor for the frequency being measured. Record power meter reading at each frequency setting.
23. Calculate the power flatness to see if the specifications are met in the 2.4 to 26.5 GHz range as shown in Table 5-11.

If the flatness is not met in either of these ranges, proceed to step 24 and make power flatness adjustments.

FLATNESS ADJUSTMENTS**NOTE**

Flatness adjustments should be performed if the ALC circuit has been adjusted, or if any assembly in the RF path from the directional coupler to the output connector (including the output connector) has been replaced. If only the ALC has been readjusted, proceed with step 28. Before making the following adjustments, check flatness using the Flatness Verification procedure.

5-38. FLATNESS VERIFICATION AND ADJUSTMENT (Cont'd)

H02 NOTE

THIS PAGE DOES NOT APPLY TO INSTRUMENTS EQUIPPED WITH OPTION H02.

Table 5-11. Flatness in 2.4 to 26.5 GHz Range

Option	Flatness (dB) Relative to 2.4 GHz Reference	
	Band 1-3 (2.4 to 20 GHz)	Band 4 (20 to 26.5 GHz)
Standard	± 1.1	± 1.6
Option 001	± 0.9	± 1.3
Option 004	± 1.3	± 1.8
Option 005	± 1.1	± 1.5

24. The frequency response correction should still be in 8750A memory from the flatness verification procedures in the previous steps. If it is not, perform the previous steps 10 through 19.
25. Press HP 8340A [INSTR PRESET], [START], then enter [2] [.] [4] [GHz]. Press [SWEEP TIME] and [AUTO]. Press [INT] LEVELING. Press [SHIFT] [PWR SWP] and enter [0] [dBm]. Press [CONT] SWEEP. Press [SLOPE] and enter the calculated correction value for the directional coupler and power sensor found in step 14. Terminate the entry with [dBm]. Press [SHIFT] [PULSE].
26. Press 8750A [INPUT – MEMORY]. Access the HP 8340A Calibration Constant Number 14 by entering the following:

[SHIFT] [GHz] [1] [4] [Hz] [SHIFT] [MHz] [1] [2] [Hz] [SHIFT] [kHz] [2] [2] [Hz]

Use the [STEP] keys to select the Calibration Constant Number and use the front panel rotary knob to change the value.

27. Refer to Figure 5-61 and make adjustments as follows:

Adjust Calibration Constant Number 14 for the flattest trace from 2.4 to 9 GHz.

Adjust Calibration Constant Number 15 and A27R4 BKPT1 for the flattest trace from 9 to 20 GHz.

Adjust Calibration Constant Number 16 and A27R8 BKPT2 for flattest trace from 20 to 26.5 GHz.

Repeat these adjustments until the flattest trace is obtained from 2.4 to 26.5 GHz.

5-38. FLATNESS VERIFICATION AND ADJUSTMENT (Cont'd)

H02 NOTE

THIS PAGE DOES NOT APPLY TO INSTRUMENTS EQUIPPED WITH OPTION H02.

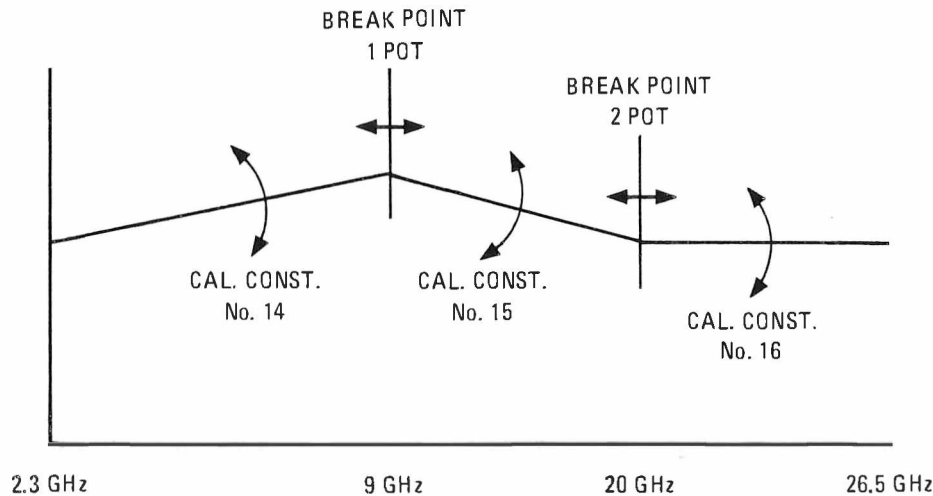

Figure 5-61. Relationship of Flatness Adjustments Diagram

28. Disconnect the directional coupler from the HP 8340A and connect the power sensor to the HP 8340A RF output. Set the power meter CAL FACTOR switch for 2.4 GHz. Press HP 8340A **[CW]** and enter **[2][.][4][GHz]**. Press **[SLOPE]** to turn it OFF and **[SHIFT][PULSE]** (turns AM LED OFF). Adjust Calibration Constant Number 44 for 0 dBm on the power meter.
29. Press HP 8340A **[CW]** and enter **[1][0][0][MHz]**. Set the power meter CAL FACTOR switch to 100%. Note the power meter indication. This power level will be P3 in the following equation.

Press HP 8340A **[CW]** and enter **[2][.][3][9][GHz]**. Set the power meter CAL FACTOR switch to include 2.39 GHz. Note the power meter indication. This value will be used as P4 in the following equation.

Calculate the value of P using the following equation:

$$P = (1.044 \times P3) - (0.044 \times P4)$$

30. Access Calibration Constant Number 13 by entering the following: **[SHIFT][GHz][1][3][Hz][SHIFT][MHz][1][2][Hz][SHIFT][kHz][2][2][Hz]**. Adjust Calibration Constant Number 13 for a power meter indication of P. Then adjust A25R108 LOFS (Figure 5-62) for a 0 dBm power meter indication.
31. Perform the Flatness Verification procedure to ensure that the HP 8340A meets its flatness specification.

5-38. FLATNESS VERIFICATION AND ADJUSTMENT (Cont'd)

A25

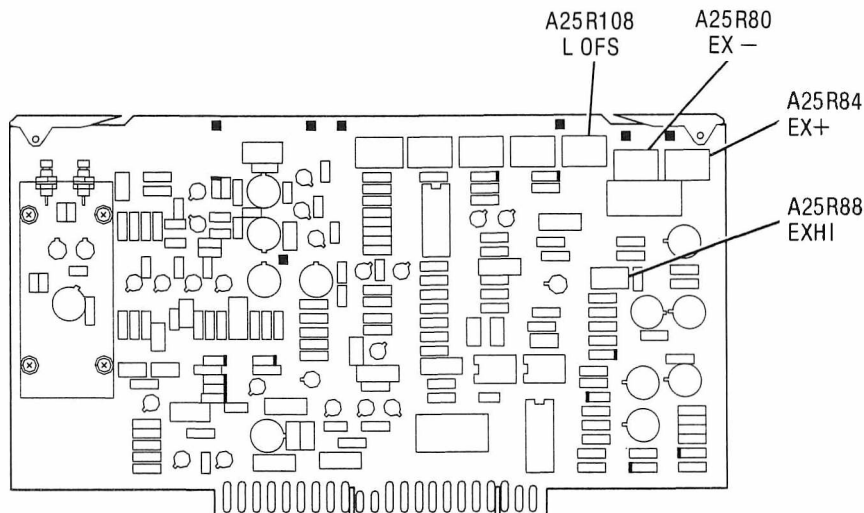

Figure 5-62. Flatness and External Leveling Adjustments Location

ADJUSTMENT AM OFFSET

32. Connect Power Meter Sensor to HP 8340A RF OUTPUT. Press **[INSTR PRESET]**. Press **[CW]** and enter **[4] [.] [5] [GHz]**. Power level should be 0 dBm. Access Calibration Constant Number 43 by entering the following: **[SHIFT] [GHz] [4] [3] [Hz] [SHIFT] [MHz] [1] [2] [Hz] [SHIFT] [kHz] [2] [2] [Hz]**. Adjust Calibration Constant Number 43 for no more than 0.05 dB change in power meter indication when turning AM ON and OFF.

ADJUST ADC CALIBRATION CONSTANTS

33. Press **[SHIFT] [PWR SWP]** to decouple the RF attenuator and ALC. RF attenuator should be at 0 dB, ALC power should be at 0 dBm, and the CW frequency should be 4.5 GHz. Press **[AM] ON**.
34. With the **[ENTRY]** keys, select +5 dBm through -20 dBm in 1 dB increments and at each position check that the **[ENTRY DISPLAY]** ALC level and the **[POWER dBm]** indications are within 0.1 dB of each other.
35. If the indications are out of tolerance, adjust Calibration Constant Number 42 in the high power range and adjust Calibration Constant Number 42 by entering the following: **[SHIFT] [GHz] [4] [2] [Hz] [SHIFT] [MHz] [1] [2] [Hz] [SHIFT] [kHz] [2] [2] [Hz]**. Use the **[STEP]** key to change to Calibration Constant Number 40. After adjustments, recheck the +5 through -20 dBm range to verify that all points are within tolerance.
36. Press **[CW]** and enter **[1] [.] [5] [GHz]**. Press **[SHIFT] [PWR SWP]**. With **[ENTRY]** keys, select +5 dBm through 4mm20 dBm in 1 dB increments and at each position check that the **[ENTRY DISPLAY]** ALC level and **[POWER dBm]** indications are within 0.1 dB of each other.

5-38. FLATNESS VERIFICATION AND ADJUSTMENT (Cont'd)

37. If the indications are out of tolerance, adjust Calibration Constant Number 39 primarily for low level power settings. Access Calibration constant Number 39 by entering the following: [SHIFT] [GHz] [3] [9] [Hz] [SHIFT] [MHz] [1] [2] [Hz] [SHIFT] [kHz] [2] [2] [Hz]. Again recheck the +5 dBm to -20 dBm range to verify that all points are within tolerance.

NOTE

If adjustments of the Calibration constants were made in this procedure, the data thus stored in the "working memory area" should be copied to the "protected memory area" by pressing the following key sequence: [SHIFT] [MHz] [1] [4] [Hz] [SHIFT] [kHz] [5] [3] [4] [9] [Hz]. Wait for "CALIBRATION RESTORED" to be displayed in the ENTRY display, then press [INSTR PRESET].

5-39. PULSE ADJUSTMENTS

NOTE

THIS ADJUSTMENT IS NOT APPLICABLE TO INSTRUMENTS EQUIPPED WITH OPTION 006, DELETE PULSE MODULATION

Reference:

Performance Test: Pulse Modulation Rise, Fall, and Delta Time; Pulse Modulation Accuracy; and Pulse Modulation Video Feedthrough

Service Section: RF Section

Description

The detector sample-and-hold balance is adjusted for best continuity across the trailing edge of the pulse waveform. The timing is adjusted for maximum negative level.

The integrator gate balance is set for the flattest pulse envelope.

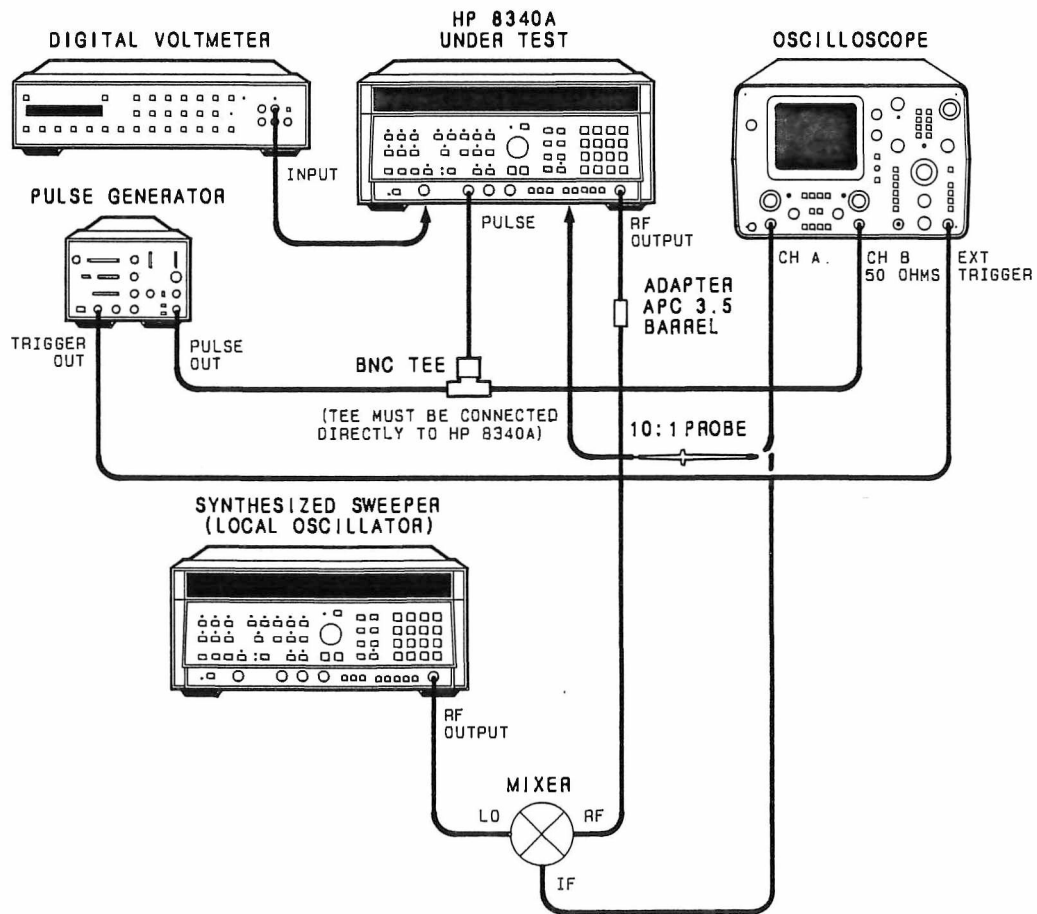

Figure 5-63. Pulse Adjustment Setup

5-39. PULSE ADJUSTMENTS (Cont'd)

NOTE

The following adjustments are required if any of the following four assemblies have been replaced or if any of the controls listed after each assembly have been adjusted or replaced.

- A11 High Band Detector (Bands 1 - 4)
- A21 Pulse Modulator Assembly, A21R21 (ON DELAY), A21R23 (OFF DELAY)
- A25 ALC Detector Assembly, A25R58 (BAL)
- A26 Linear Modulator Assembly, A26R7 (BAL)

Equipment Required:

Synthesized Sweeper	HP 8340A Opt. 001
Pulse Generator	HP 8012B
Oscilloscope	HP 1741A
10:1 Divider Probe	HP 10004D
Mixer	RHG DMS 1 - 26
Digital Voltmeter	HP 3455A

Procedure:

DETECTOR SAMPLE AND HOLD BALANCE ADJUSTMENT

1. Connect equipment as shown in Figure 5-63. Allow at least 30 minutes warmup.

NOTE

The A21, A25, and A26 PC boards must not be placed on extender boards in this adjustment procedure. Also, the cables connected to detectors A11 and A12 are especially designed for low capacitance and only these cables may be used during adjustment procedures.

2. Set the oscilloscope as follows:

DISPLAY	CHOP
MODE	MAIN
MAG X5	ON
CH A	0.005 V/Div AC COUPLED
CH B	5 V/Div 50 Ohms
TIME/Div	2 µsec

Connect CH A probe to A26TP2 (DET)

3. Set the pulse generator for a pulse width of 4 microseconds, a pulse period of 10 microseconds, and amplitude = + 3 Volts high and 0 Volts low.
4. Press the HP 8340A Under Test [INSTR PRESET]. Press [PULSE] ON. Press [CW] and enter [5][GHz]. Press [SHIFT][PWR SWP] and enter [0][dBm]. Use the stepkeys to step in 10 dB RF attenuation. If the HP 8340A does not include an RF attenuator, connect a 10 dB pad to the RF output. Set A21R21 (ON DELAY) and A21R23 (OFF DELAY) fully counterclockwise. (See Figure 5-64.)

Check that the HP 8340A Under Test is leveled (the UNLEVELED light is not lit).

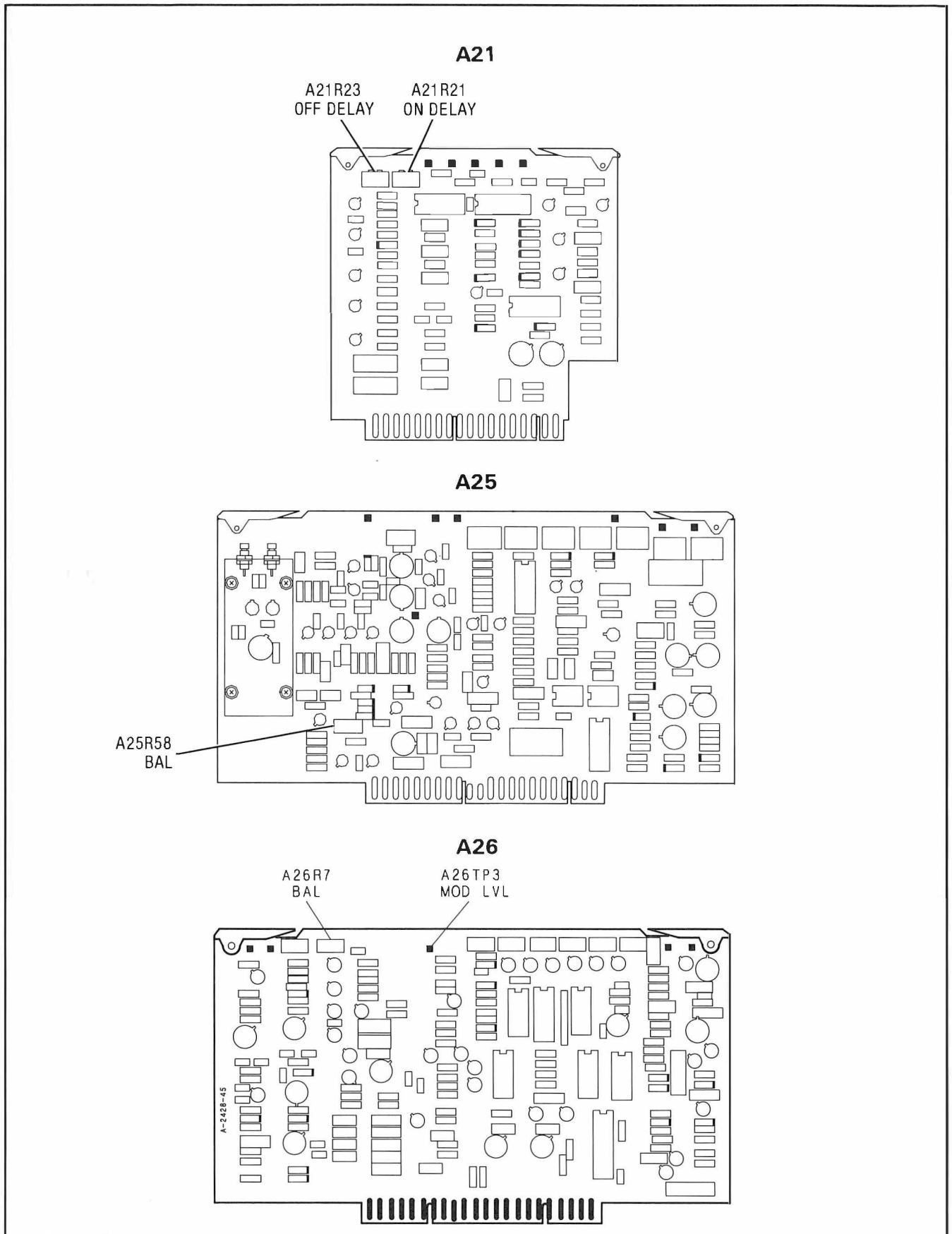
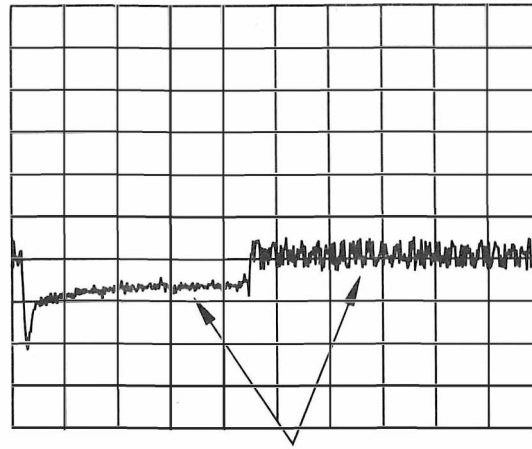

Figure 5-64. Pulse Adjustments Location

5-39. PULSE ADJUSTMENTS (Cont'd)

5. Set the oscilloscope to 1 usec/Div. The CH A trace should be similar to Figure 5-65.



ADJUST FOR SAME LEVEL.

Figure 5-65. Typical A26TP2 (DET) Pulse Waveform.

6. Adjust A25R58 (BAL) control for best continuity across the pulse trailing edge. (NOTE: A25 must not be on an extender board when viewing trace.)

SAMPLE AND HOLD TIMING ADJUSTMENT

7. Set the pulse generator for a pulse width of 120 nanoseconds. Press the 8340A Under Test **[SHIFT] [PWR SWP]** and enter **[-] [1] [0] [dBm]**. Then press **[SHIFT] [SLOPE]** and use the **[STEP]** keys to set attenuator to -10 dB.
8. Connect DVM to A26TP3 MOD LVL. Adjust A21R21 ON DELAY and A21R23 OFF DELAY for the most negative reading.
9. At the 8340A Under Test, make settings as follows:
 - a. Press **[SHIFT] [PWR SWP]** and use **[STEP]** keys to set attenuator to -10 dB.
 - b. Use keys to enter **[0] [dBm]**.
 - c. Press **[CW]** and enter **[5] [GHz]**.
10. Set the oscilloscope to 0.2 usec/DIV and adjust the Pulse Generator to a 1 usec pulse.
11. Connect the output IF port of the mixer to CH A of oscilloscope and set oscilloscope to 50 Ohm input and .005 V/DIV.
12. At the Local Oscillator, make settings as follows:
 - a. Press **[CW]** and enter **[4] [.] [9] [5] [GHz]**.
 - b. Press **[POWER LEVEL]** and enter **[1] [0] [dBm]**.

5-39. PULSE ADJUSTMENTS (Cont'd)

13. Turn pulse ON and then OFF alternately by pressing **[PULSE]** pushbutton. Adjust A25R58 BAL control so that the peak-to-peak amplitude of the envelope displayed on the oscilloscope is the same value with pulse on and pulse off.

INTEGRATOR GATE BALANCE ADJUSTMENT

14. Set the pulse generator for a pulse width of 5 microseconds and a pulse period of 20 microseconds. Set oscilloscope to 1 usec/Div.
15. Press 8340A Under Test **[SHIFT] [AM]** and adjust A26R7 BAL for the flattest pulse envelope on the CH A display.

Press **[AM]** OFF and the pulse envelope should be flatter.

5-40. YO LOOP GAIN AND PHASE MARGIN TEST AND ADJUSTMENT**Reference:**

Performance Test: None

Service Section: Sweep Generator – YO Loop

Description:

This procedure selects a value of resistor A49R18 to place the YO Loop gain and phase within specified limits to prevent the YO Loop from oscillating while still providing sufficient gain in the YO Loop.

NOTE

This procedure should be performed only after a YO failure or repair, or after replacing any assembly in the YO Loop.

NOTE

The YO Driver A55 should be aligned as described in Paragraph 5-29 prior to this procedure.

Equipment Required:

Spectrum Analyzer	3585A
Special Test Fixture	Fabricated Locally

Procedure:

1. Fabricate special test fixture as shown in Figure 5-66.
2. Place the YO Loop in the Service Position and remove the cover from A49 Phase Detector board. Remove jumper A49W1 from Phase Detector board.
3. Connect Special Test Fixture and Spectrum Analyzer to YO Loop as shown in Figure 5-67.
4. On the Special Test Fixture, set S1 to position 1 and set S2 to J2 position. The YO Loop should now be locked as indicated by A50DS1 (green LED) being lit.
5. On the 8340A, press [**INSTR PRESET**] [**CW**] [**3**] [**GHz**].
6. On the 3585A Spectrum Analyzer, make the following settings:

INSTR PRESET	Press
TRACKING GENERATOR AMPLITUDE	Fully Clockwise (0 dBm)
INPUT IMPEDANCE	1 Megohm
AUTO RANGE	OFF
REF. LVL. TRK	OFF
START FREQ.	0 Hz
STOP FREQ.	100 kHz
dB/div.	1 dB/div.
REF. LEVEL	-25 dBm
RANGE (use STEP keys)	-15 dBm

5-40. YO LOOP GAIN AND PHASE MARGIN TEST AND ADJUSTMENTS (Cont'd)

7. A trace similar to Figure 5-68, Waveform A should be displayed on the Spectrum Analyzer.
8. On the 3585A Spectrum Analyzer, press [STORE A→B] to store the trace from A into Trace B. On the Special Test Fixture, set switch S1 to position 2. The 3585A Spectrum Analyzer should display the two traces similar to Figure 5-68, Waveform B.
9. Using the rotary knob on the Spectrum Analyzer, move the marker to the point where the two traces cross. Observe the marker frequency on the Spectrum Analyzer. The marker (crossover frequency) should be between 45 and 55 kHz.
10. If the crossover frequency is below 45 kHz, then the value of A49R18 on the A49 YO Phase Detector board should be decreased in value to increase the crossover frequency. If the crossover frequency is above 55 kHz, then the value of A49R18 should be increased to lower the crossover frequency.
11. If the crossover frequency is good, then the phase margin is checked next. Make sure the marker is at the crossover frequency, then set switch S1 on the Special Test Fixture to position 1. On the Spectrum Analyzer, press Marker [OFFSET], then marker [ENTER OFFSET]. The offset should now display 0 dB. On the Special Test Fixture, set switch S2 to the [SHORT] position. (The A50DS1 green LED should be off.) Read the offset in dB and insert the dB measurement into the following formula to determine the phase margin in degrees:

$$K=10 ((\text{dB measurement})/20)$$

$$\text{Phase Margin}=\text{ACS}((2-K^2)/2)$$

NOTE: ACS is arccosine function; phase margin is in degrees.

0 dB = 60 degree phase margin; -2.3 dB = 45 degree phase margin; +2 dB = 75 degrees phase margin.

The phase margin should be between 45 degrees and 75 degrees.

GAIN AT 2 KHZ

12. On the Spectrum Analyzer, make the following settings:

INSTR PRESET	Press
INPUT IMPEDANCE	1 Megohm
AUTO RANGE	OFF
REF. LVL. TRK	OFF
REF. LEVEL	-15 dBm
RANGE (use STEP keys)	-15 dBm
RBW	3 Hz
VBW	1 Hz
MANUAL SWEEP	2 kHz

13. On the Special Test Fixture, set switch S2 to J2 and set switch S1 to position 1.

5-40. YO LOOP GAIN AND PHASE MARGIN TEST AND ADJUSTMENTS (Cont'd)

14. On the Spectrum Analyzer, press marker [OFFSET] then marker [ENTER OFFSET] and change switch S1 on the Special Test Fixture to position 2. Observe the offset measurement in dB on the Spectrum Analyzer. This is the gain at 2 kHz and should be >37 dB.
15. Disconnect all test equipment from the 8340A, reinstall jumper W1 on A49 Phase Detector board, and reinstall the YO Loop into the 8340A.

SPECIAL TEST FIXTURE SCHEMATIC DIAGRAM

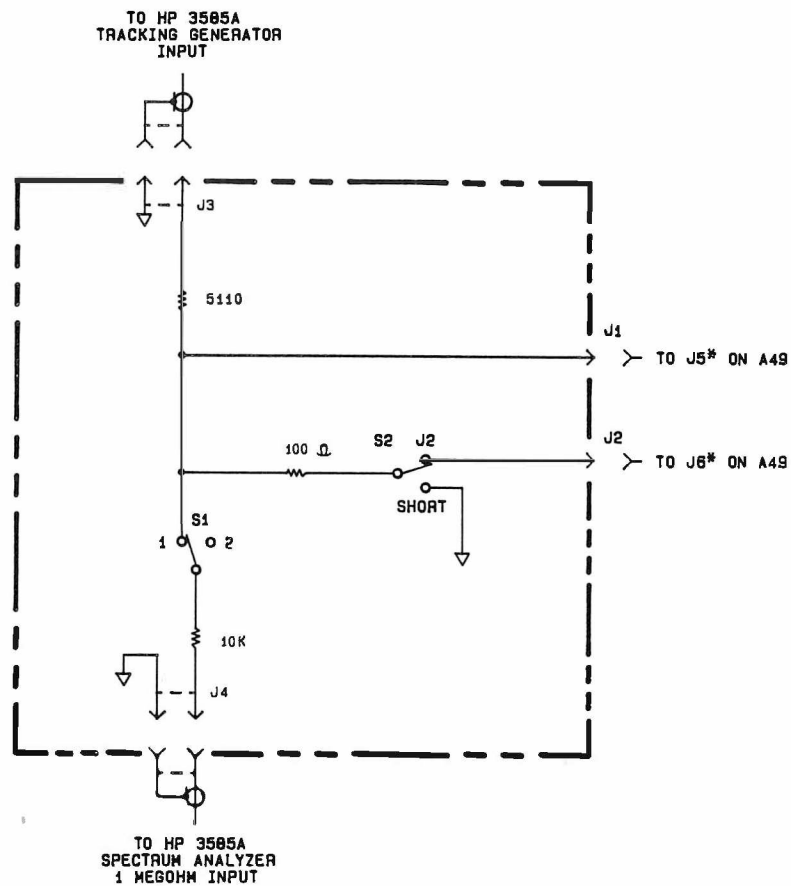

***NOTE**
ON 8340A INSTRUMENTS WITH
SERIAL PREFIX BELOW 2337A,
A49J5 IS A49J1 AND A49J6 IS
A49J2.

Figure 5-66. Special Test Fixture Fabrication Instructions (1 of 2)

TOP VIEW

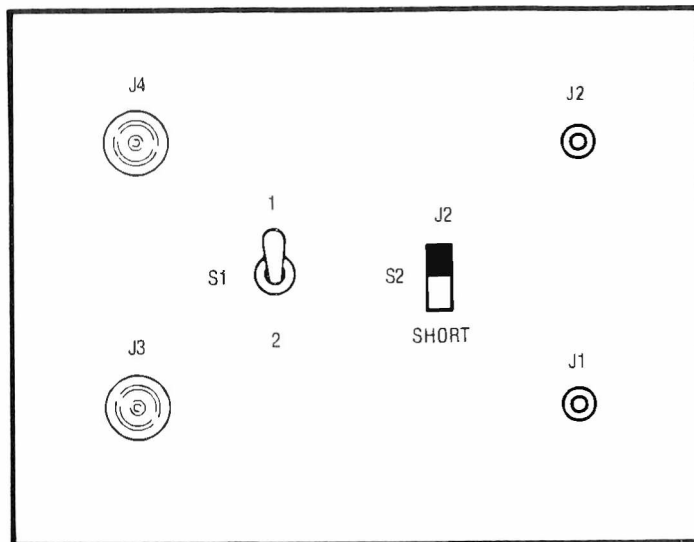

BOTTOM VIEW

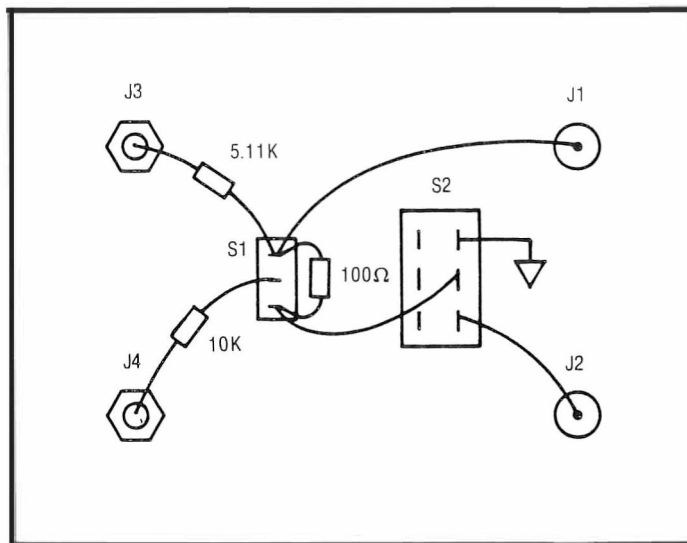

YO Special Test Fixture Material List

Qty	Description	HP Part Number	Qty	Description	HP Part Number
1	BUD BOX 2.75 X 2.1	7100-1207	2	CHASSIS MOUNT SNAP ON (M)	1250-0691
1	SWITCH SPDT (TOGGLE)	3101-0163	2	LOCK WASHER	2190-0124
1	SWITCH DPDT (SLIDE)	3101-0070 (only requires a SPDT)	2	NUT	2950-0078
2	CHASSIS MOUNT BNC (F)	1250-0212	1	10kΩ ¼W RESISTOR	0757-0442
2	LOCK WASHER	2190-0016	1	100Ω ¼W RESISTOR	0757-0401
2	NUT	2950-0001	1	5.11kΩ ¼W RESISTOR	0757-0438

Figure 5-66. Special Test Fixture Fabrication Instructions (2 of 2)

5-40. YO LOOP GAIN AND PHASE MARGIN TEST AND ADJUSTMENTS (Cont'd)

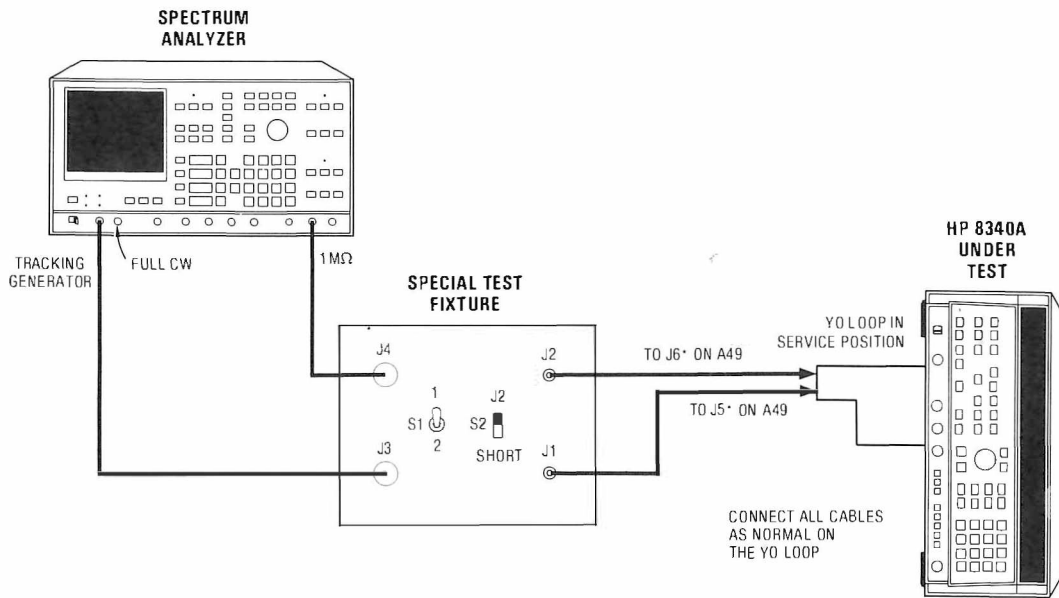

Figure 5-67. YO Loop Gain Test Setup

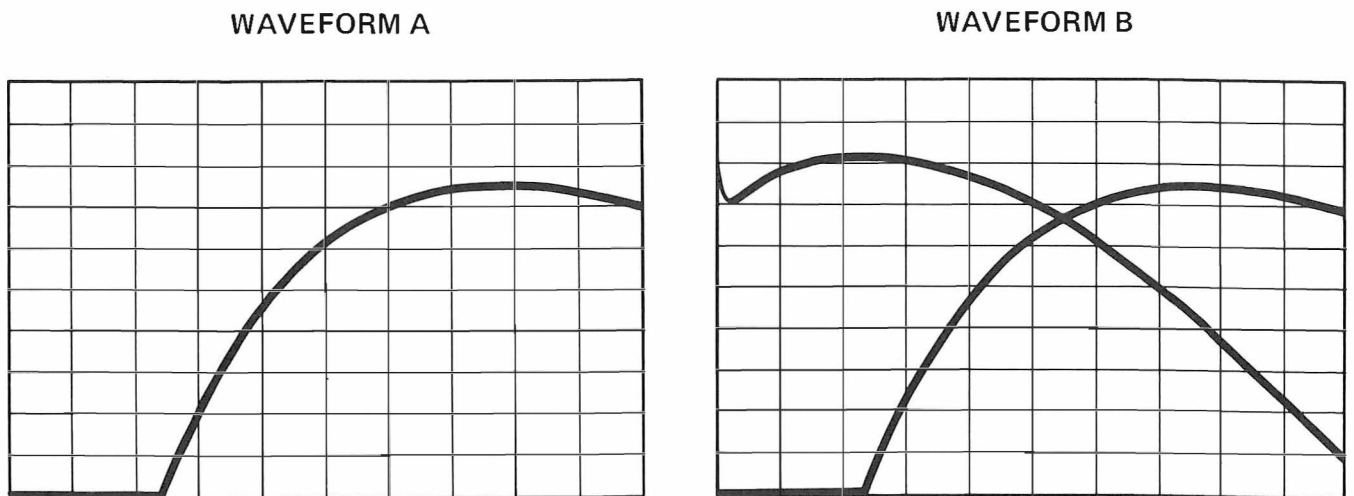

Figure 5-68. Spectrum Analyzer Waveforms of YO Loop Gain

SECTION VI REPLACEABLE PARTS

6-1. INTRODUCTION

6-2. This section contains information for ordering parts. Table 6-2 lists abbreviations used in the parts list and the names and addresses that correspond to the manufacturer's code numbers. Table 6-3 lists all replaceable parts in reference designator order.

WARNING

Any service or adjustments performed with the protective covers removed should only be done by qualified service personnel. A shock hazard exists with the covers removed.

6-3. EXCHANGE ASSEMBLIES

6-4. Table 6-1 lists assemblies within the instrument that may be replaced on an exchange basis, thus affording a considerable cost saving. Exchange, factory-repaired and tested assemblies are available only on a trade-in basis; therefore, the defective assemblies must be returned for credit. For this reason, assemblies required for spare parts stock must be ordered by the new assembly part number. Refer to Section VIII Service for additional information on the Rebuilt-Exchange program.

6-5. ABBREVIATIONS

6-6. Table 6-2 lists abbreviations used in the parts list and schematics. In some cases, two forms of the abbreviation are used, one all in capital letters, and one partial or no capitals. This occurs because the abbreviations in the parts list are always capitals. However, in the schematics, other abbreviation forms are used with both lower case and upper case letters.

6-7. REPLACEABLE PARTS LIST

6-8. Table 6-3 is the list of replaceable parts and is organized as follows:

- a. Electrical assemblies and their components in alpha-numerical order by reference designation.
- b. Miscellaneous electrical and chassis-mounted parts in alpha-numerical order by reference designation.
- c. Option configuration instruments.
- d. Miscellaneous mechanical and chassis parts.

6-9. The information given for each part consists of the following:

- a. The Hewlett-Packard part number.
- b. Part number Check Digit (CD).
- c. The total quantity (Qty.) in the major assembly (A1, A2, or A3, etc.).
- d. The description of the part.
- e. A typical manufacturer of the part in a five-digit code.
- f. The manufacturer's part number for the part.

6-10. The total quantity for each part is given only once — at the first appearance of the part number in the list for each major assembly.

NOTE

Total quantities for optional assemblies are totaled by assembly and not integrated into the standard list.

6-11. ORDERING INFORMATION

6-12. To order a part listed in the replaceable parts table, quote the Hewlett-Packard Part Number (with Check Digit), indicate the quantity required, and address the order to the nearest Hewlett-Packard office. Including the Check Digit will ensure accurate and timely processing of your order.

6-13. To order a part that is not listed in the Replaceable Parts List, include the instrument

model number, instrument serial number, description and function of the part, and the number of parts required. Address the order to the nearest Hewlett-Packard office.

6-14. 2 YEAR WARRANTED MICROCIRCUITS

6-15. Table 6-1b lists assemblies within the instrument that are warranted for 2 years from date of sale. Refer to the warranty statement in the beginning of Volume 1, Operating Manual, for conditions and details of this warranty.

Table 6-1. Exchange Parts

Description	New Part Number	C D	Rebuilt-Exchange Part Number	C D
A8 Band 0 3.7 GHz Oscillator	5086-7309	3	5086-6309	1
A9 Band 0 Pulse Modulator	5086-7372	0	5086-6372	8
A13 Band 0-4 SYTM	08340-60241	0	08340-60242	1
A14 Band 1-4 Power Amplifier (2.3 to 7.0 GHz)	5086-7407	1	5086-6407	9
A16 Band 1-4 Modulator/Splitter	5086-7304	8	5086-6304	6
A17 Band 0 Mixer	5086-7374	2	5086-6374	0
A18 Band 0 Power Amplifier (0.01 to 2.4 GHz)	5086-7217	2	5086-6217	0
A44 YIG Oscillator	5086-7327	1	5086-6323	9
A63 90 dB Programmable Attenuator	08340-60175	9	08340-60223	8

Table 6-1b. 2 Year Warranted Microcircuits

Assembly Number	Part Number	Description
A8	5086-7309 5086-6309	3.7 GHz Oscillator Exchange 5086-7309
A9	5086-7372 5086-6372	Band 0 Pulse Modulator Exchange 5086-7372
A12	5086-7434	Band 0 Splitter/Detector
A13	5086-7308 5086-6308	SYTM (Order new part replacement kit 08340-60241, CD0) Exchange 5086-7308 (Order exchange part replacement kit 08340-60242, CD1)
A13	5086-7508 5086-6508	SYTM (Order new part replacement kit 08340-60241, CD0) Exchange 5086-7508 (Order exchange part replacement kit 08340-60242, CD1)
A14	5086-7407 5086-6407	Band 1-4 Power Amp, Standard Exchange 5086-7407
A16	5086-7304 5086-6304	Modulator/Splitter Exchange 5086-7304
A17	5086-7374 5086-6374	Band 0 Mixer Exchange 5086-7374
A18	5086-7217 5086-6217	Band 0 Power Amplifier Exchange 5086-7217
A44	5086-7323 5086-6323	YIG Oscillator Exchange 5086-7323
A48U1	5086-7292	YO Sampler

Table 6-2. *Manufacturer's Code List, Reference Designations, and Abbreviations (1 of 4)*

MANUFACTURER'S CODE LIST			
Mfr. No.	Manufacturer Name	Address	Zip Code
00000	ANY SATISFACTORY SUPPLIER		
0003J	NIPPON ELECTRIC CO.	TOKYO JA	
00046	UNITRODE COMPUTER PRODUCTS CORP.	METHUEN MA	
01121	ALLEN-BRADLEY CO.	MILWAUKEE WI	53204
01295	TEXAS INSTR. INC. SEMICOND CMPNT. DIV.	DALLAS TX	53204
01921	RCA CORP SOLID STATE DIV.	SOMERVILLE NJ	75222
02111	SPECTROL ELECTRONICS CORP.	CITY OF IND CA	08876
03888	KDI PYROFILM CORP.	WHIPPANY NJ	91745
04713	MOTOROLA SEMICONDUCTOR PRODUCTS	PHOENIX AZ	07981
06001	GE CO ELEK CAP & BAT PROD. DEPT.	IRMO SC	85062
06665	PRECISION MONOLITHICS INC.	SANTA CLARA CA	29063
07263	FAIRCHILD SEMICONDUCTOR DIV.	MOUNTAIN VIEW CA	95050
11236	CTS OF BERNE INC.	BERNE IN	94042
13606	SPRAGUE ELECT. CO. SEMICONDUCTOR DIV.	CONCORD NH	46711
16179	OMNI SPECTRA INC.	FARMINGTON MI	03301
17856	SILICONIX INC.	SANTA CLARA CA	03504
18324	SIGNETICS CORP.	SUNNYVALE CA	95054
19701	MEPCO/ELECTRA CORP.	MINERAL WELLS TX	94086
20932	EMCON DIV. ITW	SAN DIEGO CA	76067
24355	ANALOG DEVICES INC.	NORWOOD MA	92129
24546	CORNING GLASS WORKS (BRADFORD)	BRADFORD PA	02062
25088	SIEMENS CORP.	ISELIN NJ	16701
27014	NATIONAL SEMICONDUCTOR CORP.	SANTA CLARA CA	08830
28480	HEWLETT-PACKARD CO. CORPORATE HQ.	PALO ALTO CA	95051
30983	MEPCO/ELECTRA CORP.	SAN DIEGO CA	94304
32997	BOURNS INC. TRIMPOT PROD. DIV.	RIVERSIDE CA	92121
34371	HARRIS SEMICON DIV HARRIS-INTERTYPE	MELBOURNE FL	92507
34649	INTEL CORP.	MOUNTAIN VIEW CA	32901
51642	CENTRE ENGINEERING INC.	STATE COLLEGE PA	95051
56289	SPRAGUE ELECTRIC CO.	NORTH ADAMS MA	16801
72116	ELECTRO MOTIVE CORP. SUB IEC	WILLIMANTIC CT	01247
73138	BECKMAN INSTRUMENTS INC. HELIPOT DIV.	FULLERTON CA	06226
74970	JOHNSON E F CO.	WASECA MN	92634
			56093

Table 6-2. Manufacturers Code List, Reference Designations, and Abbreviations (2 of 4)

REFERENCE DESIGNATIONS		
A..... Assembly	FL..... Filter	S..... Switch
AT..... Attenuator, Isolator, Limiter, Termination	H..... Hardware	T..... Transformer
B..... Fan, Motor	HY..... Circulator	TB..... Terminal Board
BT..... Battery	J..... Electrical Connector (Stationary Portion), Jack	TC..... Thermocouple
C..... Capacitor	K..... Relay	TP..... Test Point
CP..... Coupler	L..... Coil, Inductor	U..... Integrated Circuit, Microcircuit
CR..... Diode, Diode Thyristor, Step Recovery Diode (SCR), Varactor	M..... Meter	V..... Electron Tube
DC..... Directional Coupler	MP..... Miscellaneous Mechanical Part	VR..... Breakdown Diode (Zener), Voltage Regulator
DL..... Delay Line	P..... Electrical Connector (Movable Portion), Plug	W..... Cable, Transmission Path, Wire
DS... Annunciator, Lamp, Light Emitting Diode (LED), Signaling Device (Audible or Visible)	Q... Silicon Controlled Rectifier (SCR), Transistor, Triode Thyristor	X..... Socket
E..... Miscellaneous Electrical Part	R..... Resistor	Y..... Crystal Unit (Piezoelectric, Quartz)
F..... Fuse	RT..... Thermistor	Z..... Tuned Cavity, Tuned Circuit
ABBREVIATIONS		
ADC..... Analog-to-Digital Converter	CAL..... Calibrate, Calibration	E
ADJ..... Adjust, Adjustment	CBL..... Cable	ECL.... Emitter-Coupled Logic
AG..... Silver	CER..... Ceramic	EFF..... Effective
AL..... Aluminum	CHAM..... Chamfer	ENCDR..... Encoder
AMP..... Amperage	CHAN..... Channel	EXCL.... Excluding, Exclusive
ANDZ..... Anodized	CNTR..... Container, Counter	EXT..... Extended, Extension, External, Extinguish
ANLG..... Analog	COM.... Commercial, Common	EXTR..... Extractor
ASTBL..... Astable	CONN... Connect, Connection, Connector	
AWG..... American Wire Gage	CONT.... Contact, Continuous, Control, Controller	F
B	CRP..... Crepe, Crimp	F... Fahrenheit, Farad, Female, Film (Resistor), Fixed, Flange, Flint, Fluorine, Frequency
BCD.... Binary Coded Decimal	CTR..... Center	FDTHRU..... Feed Through
BCKT..... Bracket	CU..... Copper, Cubic	FET.... Field-Effect Transistor
BD..... Board, Bundle	CURRNT..... Current	FF..... Flange, Female Connection; Flip Flop
BE..... Baume, Beryllium	D	FL..... Flash, Flat, Fluid
BFR..... Before, Buffer	D..... Deep, Depletion, Depth, Diameter, Direct Current	FLEX..... Flexible
BIN..... Bin Box (Container), Binary	DAC..... Dacron	FLG..... Flange
BNC..... Type of Connector	DAP..... Diallyl Phthalate	FLTR..... Filter, Floater
BSC..... Basic	DB..... Decibel, Double Break	FRTD..... Flame Retardant
BSHG..... Bushing	DBL..... Double	FT.... Current Gain Bandwidth Product (Transition Frequency); Feet, Foot
BVR..... Reverse Breakdown Voltage	DCDR..... Decoder	FXD..... Fixed
C	DECD..... Decade	G
C..... Capacitance, Capacitor, Center Tapped, Centistoke, Ceramic, Cermet, Circular Mil Foot, Closed Cup, Cold, Compression	DEG..... Degree	GEN..... General, Generator
	DIVR..... Divider	
	DO..... Package Type Designation	
	DRVR..... Driver	
	DUAL..... Two	

Table 6-2. Manufacturers Code List, Reference Designations, and Abbreviations (3 of 4)

GHZ..... Gigahertz	M	P.C..... Printed Circuit
GL..... Glass	M..... Male, Maximum, Mega,	PCB..... Printed Circuit Board
GP.... General Purpose, Group	Mil, Milli, Mode, Momentary,	PD..... Pad, Palladium, Pitch
GRN..... Green	Mounting Hole Centers,	Diameter, Power Dissipation
GRV..... Grooved	Mounting Hole Diameter	PF..... Picofarad; Pipe, Female
H	MA..... Milliamper	Connection; Power Factor
H..... Henry, Hermaphrodite,	MAGTD..... Magnitude	PKG..... Package
High, Hole Diameter, Hot, Hub	MCD..... Millicandela	PL-MTG..... Plate Mounting
Inside Diameter, Hydrogen	MIN.... Miniature, Minimum,	PLSTC..... Plastic
HD..... Hand, Hard, Head,	Minor, Minute	PN..... Part Number
Heavy Duty	MIR..... Mirror	PNP..... Positive Negative
HEX... Hexadecimal, Hexagon,	MLD..... Mold, Molded	Positive (Transistor)
Hexagonal	MM..... Magnetized Material	POLYC..... Polycarbonate
HGT..... Height	(Restricted Articles Code);	POLYE..... Polyester
HLCL..... Helical	Millimeter	POLYL..... Polyimide
HS... Heat Sealed, Heat Shrink,	MNT..... Minute (Angle)	POS..... Position, Positive
High Speed	MO... Metal Oxide, Milliounce,	POZI..... Pozidriv Recess
I	Molybdenum	PRCN..... Precision
IC..... Collector Current,	MOM..... Momentary,	PRESCR..... Pre-Scaler
Integrated Circuit	Motherboard	PRIM..... Primary
ID..... Identification, Inside	MONO..... Monostable	PRL..... Parallel
Diameter	MONOSTBL..... Monostable	PRP..... Purple, Purpose
IMPD..... Impedance	MTG..... Mounting	P/S..... Power Supply
IN..... Inch, Indium	MTLC..... Metallic	PT..... Part, Pint, Platinum,
INP..... Input	MULTR..... Multiplier	Point, Pulse Time
INS... Insert, Inside, Insulation,	MW..... Milliwatt	PVC..... Polyvinyl Chloride
Insulator	N	Q
INT..... Integral, Intensity,	NB..... Niobium	QUAD..... Set of Four
Internal	NCH..... Notched	R
INTL.... Internal, International	NEG..... Negative	RBN..... Ribbon
INV..... Invert, Inverter	NH..... Nanohenry	RCVR..... Receiver
IR..... Insulation Resistance,	NM... Nanometer, Nonmetallic	RECT..... Rectangle,
Iridium	NOR..... Logic Not-OR	Rectangular, Rectifier
K	NPN..... Negative Positive	RES..... Research, Resistance,
K..... Kelvin, Key, Kilo,	Negative (Transistor)	Resistor, Resolution
Potassium	NS..... Nanosecond,	RETRIG..... Retriggerable
KB..... Knob	Non-Shorting, Nose	RFI..... Radio Frequency
L	NTD..... Non-Time-Delay	Interference
LCH..... Latch	NYL..... Nylon (Polyamide)	RGLTR..... Regulator
LED..... Light Emitting Diode	O	RGTR..... Register
LG..... Length, Long	OCTL..... Octal	RND..... Round
LKG..... Leakage, Locking	OD..... Olive Drab, Outside	RVT..... Rivet, Riveted
LKWR..... Lockwasher	Diameter	S
LS.... Loudspeaker, Low Power	OP AMP..... Operational	SCR..... Screw, Scrub, Silicon
Schottky, Series Inductance	Amplifier	Controlled Rectifier
LUM..... Luminous	P	SEC..... Second, Secondary
	PC..... Picocoulomb, Piece,	SEN..... Sense, Sensing
	Printed Circuit	

Table 6-2. Manufacturers Code List, Reference Designations, and Abbreviations (4 of 4)

SENS..... Sensitive, Sensitivity	TA..... Ambient Temperature,	W
SER..... Serial, Series	Tantalum	
SGL..... Single	TC..... Thermoplastic	W..... Watt, Wattage, White,
SHF..... Shift, Super High	TERMS..... Terminals	Wide, Width, Wire
Frequency	TFE... Polytetrafluoro-ethylene,	WD..... Width, Wood
SHFT..... Shaft	Teflon	
SHLDR..... Shoulder	THD..... Thread, Threaded	X
SI..... Silicon, Square Inch	THK..... Thick	
SIG..... Signal, Significant	THKNS..... Thickness	XSTR..... Transistor
SIP..... Single In-Line Package	TPL..... Triple	
SKT..... Skirt, Socket	TR..... Rise Time, Truss	Y
SLDR..... Solder	TRIG..... Trigger, Triggerable,	
SM..... Samarium, Seam, Small,	Triggering, Trigonometry	YTM.... YIG-Tuned Modulator
Square Meter, Sub Modular,	TRMR..... Trimmer	
Subminiature	TRN..... Turn, Turns	Z
SMB..... Subminiature, B Type	TTL..... Tan Translucent,	
(Snap-On Connector)	Transistor Transistor Logic	ZNR..... Zener
SNP..... Snap		
SPCL..... Special	U	
SQ..... Square		
SST..... Stainless Steel	UCD..... Microcandela	
STDF..... Standoff	UF..... Microfarad	
STRP..... Strapped, Strip	UNCT..... Undercut	
SYNTH..... Synthetic	UVEROM.... Ultraviolet Erase	
SZ..... Size	Read Only Memory	
	V	
T		
T..... Tab Width, Taper, Teeth,	VCO..... Voltage Controlled	
Temperature, Tera, Tesla,	Oscillator	
Thermoplastic (Insulation),	VCXO..... Voltage Controlled	
Thickness, Time, Timed, Tooth,	Crystal Oscillator	
Turns Ratio, Typical	VDC..... Volts, Direct Current	
	VVC..... Voltage Variable	
	Capacitor	

Table 6-3. Replaceable Parts

Reference Designation	HP Part Number	C D	Qty	Description	Mfr Code	Mfr Part Number
A1	08340-60007	6	1	ALPHA DISPLAY ASSEMBLY	28480	08340-60007
				NOTE A1J1, HP Part Number 1251-6798, must be cut to length prior to replacement.		
A1J1	1251-6798	9	1	CONNECTOR PC 36-CONT M	03206	65647-136
A1U1-7	1990-0553	8	7	DISPLAY ANNUNCIATOR .15-IN-HIGH	01542	QDSP-2049, CAT C
A2	08340-60182	8	1	DISPLAY DRIVER ASSEMBLY	28480	08340-60182
A2C1	0160-2055	9	2	CAPACITOR-FXD .01UF +80-20% 100VDC CER	28480	0160-2055
A2C2	0160-4084	8	2	CAPACITOR-FXD .1UF +20% 50VDC CER	28480	0160-4084
A2C3	0160-2055	9	9	CAPACITOR-FXD .01UF +80-20% 100VDC CER	28480	0160-2055
A2C4	0160-4084	8	8	CAPACITOR-FXD .1UF +20% 50VDC CER	28480	0160-4084
A2C5	0160-4535	4	1	CAPACITOR-FXD 1UF +10% 50VDC CER	28480	0160-4535
A2CR1	1901-0033	2	2	DIODE-GEN PRP 180V 200MA DO-7	28480	1901-0033
A2CR2	1901-0033	2	2	DIODE-GEN PRP 180V 200MA DO-7	28480	1901-0033
A2DS1	1990-0699	3	3	L.E.D. (RED) 7 MCD	01542	LLM1-2350
				NOTE A2DS2-6, 8, 9 and 12 are matched for luminous intensity at the factory. Any single LED may be ordered separately by the part number given for each but its luminous intensity may not match that of the others on the assembly. A complete matched set may be ordered as HP Part Number 1990-0887, CDi.		
A2DS2	1990-0700	7	3	L.E.D. (YELLOW) 5 MCD	01542	LLM1-2450
A2DS3	1990-0697	1	5	L.E.D. (YELLOW) 2 MCD	01542	LLM1-2400
A2DS4	1990-0697	1	1	L.E.D. (YELLOW) 2 MCD	01542	LLM1-2400
A2DS5	1990-0697	1	1	L.E.D. (YELLOW) 2 MCD	01542	LLM1-2400
A2DS6	1990-0697	1	1	L.E.D. (YELLOW) 2 MCD	01542	LLM1-2400
A2DS7	1990-0699	3	3	L.E.D. (RED) 7 MCD	01542	LLM1-2350
A2DS8	1990-0700	7	7	L.E.D. (YELLOW) 5 MCD	01542	LLM1-2450
A2DS9	1990-0697	1	1	L.E.D. (YELLOW) 2 MCD	01542	LLM1-2400
A2DS10	1990-0696	0	2	LED-LIGHT BAR MODULE LUM-INT=3MCD	01542	LLM1-2300
A2DS11	1990-0696	0	0	LED-LIGHT BAR MODULE LUM-INT=3MCD	01542	LLM1-2300
A2DS12	1990-0700	7	7	L.E.D. (YELLOW) 5 MCD	01542	LLM1-2450
A2DS13	1990-0699	3	3	L.E.D. (RED) 7 MCD	01542	LLM1-2350
A2J1	1251-6063	1	1	CONNECTOR-PC 10 FEMALE IR	28480	1251-6063
				NOTE HP Part Number 1251-6798 (A2J2-4, 6-10, 12 and 14-17) must be cut to length prior to replacement.		
A2J2	1200-0681	0	15	SOCKET-STRP 20-CONT DIP-SLDR	28480	1200-0681
A2J3	1200-0681	0	0	SOCKET-STRP 20-CONT DIP-SLDR	28480	1200-0681
A2J4	1200-0681	0	0	SOCKET-STRP 20-CONT DIP-SLDR	28480	1200-0681
A2J5	1251-6787	6	3	SOCKET-STRIP 6 CONTACT	28480	1251-6787
A2J6	1200-0681	0	0	SOCKET-STRP 20-CONT DIP-SLDR	28480	1200-0681
A2J7	1200-0681	0	0	SOCKET-STRP 20-CONT DIP-SLDR	28480	1200-0681
A2J8	1200-0681	0	0	SOCKET-STRP 20-CONT DIP-SLDR	28480	1200-0681
A2J9	1200-0681	0	0	SOCKET-STRP 20-CONT DIP-SLDR	28480	1200-0681
A2J10	1200-0681	0	0	SOCKET-STRP 20-CONT DIP-SLDR	28480	1200-0681
A2J11	1251-6787	6	6	SOCKET-STRIP 6 CONTACT	28480	1251-6787
A2J12	1200-0681	0	0	SOCKET-STRP 20-CONT DIP-SLDR	28480	1200-0681
A2J13	1251-6788	7	1	SOCKET-STRIP 16 CONTACT	28480	1251-6788
A2J14	1200-0681	0	0	SOCKET-STRP 20-CONT DIP-SLDR	28480	1200-0681
A2J15	1200-0681	0	0	SOCKET-STRP 20-CONT DIP-SLDR	28480	1200-0681
A2J16	1200-0681	0	0	SOCKET-STRP 20-CONT DIP-SLDR	28480	1200-0681
A2J17	1200-0681	0	0	SOCKET-STRP 20-CONT DIP-SLDR	28480	1200-0681
A2J18	1251-6787	6	6	SOCKET-STRIP 6 CONTACT	28480	1251-6787
A2MP1	08340-20060	7	10	STANDOFF PRIM	28480	08340-20060
A2MP2	08340-20060	7	7	STANDOFF PRIM	28480	08340-20060
A2MP3	08340-20060	7	7	STANDOFF PRIM	28480	08340-20060
A2MP4	08340-20060	7	7	STANDOFF PRIM	28480	08340-20060
A2MP5	08340-20060	7	7	STANDOFF PRIM	28480	08340-20060
A2MP6	08340-20060	7	7	STANDOFF PRIM	28480	08340-20060
A2MP7	08340-20060	7	7	STANDOFF PRIM	28480	08340-20060
A2MP8	08340-20060	7	7	STANDOFF PRIM	28480	08340-20060

See introduction to this section for ordering information
*Indicates factory selected value

Table 6-3. Model 8340A Replaceable Parts

Reference Designation	HP Part Number	C D	Qty	Description	Mfr Code	Mfr Part Number
A2MP9	08340-20060	7		STANDOFF PRIM	28480	08340-20060
A2MP10	08340-20060	7		STANDOFF PRIM	28480	08340-20060
A2MP11	08340-20061	8	8	STANDOFF-SEC	28480	08340-20061
A2MP12	08340-20061	8		STANDOFF-SEC	28480	08340-20061
A2MP13	08340-20061	8		STANDOFF-SEC	28480	08340-20061
A2MP14	08340-20061	8		STANDOFF-SEC	28480	08340-20061
A2MP15	08340-20061	8		STANDOFF-SEC	28480	08340-20061
A2MP16	08340-20061	8		STANDOFF-SEC	28480	08340-20061
A2MP17	08340-20061	8		STANDOFF-SEC	28480	08340-20061
A2MP18	08340-20061	8		STANDOFF-SEC	28480	08340-20061
A2MP19	08340-20063	0	2	STANDOFF-SHORT	28480	08340-20063
A2MP20	08340-20063	0		STANDOFF-SHORT	28480	08340-20063
A2MP21	08340-20066	3	6	SPACER POST	28480	08340-20066
A2MP22	08340-20066	3		SPACER POST	28480	08340-20066
A2MP23	08340-20066	3		SPACER POST	28480	08340-20066
A2MP24	08340-20066	3		SPACER POST	28480	08340-20066
A2MP25	08340-20066	3		SPACER POST	28480	08340-20066
A2MP26	08340-20066	3		SPACER POST	28480	08340-20066
A2MP27-43	1200-0172	4	17	INSULATOR-XSTR DAP-GL	28480	1200-0172
A2MP44	1200-0173	5	5	INSULATOR-XSTR DAP-GL	28480	1200-0173
A2MP45	1200-0173	5		INSULATOR-XSTR DAP-GL	28480	1200-0173
A2MP46	1200-0173	5		INSULATOR-XSTR DAP-GL	28480	1200-0173
A2MP47	1200-0173	5		INSULATOR-XSTR DAP-GL	28480	1200-0173
A2MP48	1200-0173	5		INSULATOR-XSTR DAP-GL	28480	1200-0173
NOTE						
HP Part Number 1200-0681 (A2P1,2) must be cut to length prior to replacement.						
A2P1	1200-0681	0		SOCKET-STPR 20-CONT DIP-SLDR	28480	1200-0681
A2P2	1200-0681	0		SOCKET-STPR 20-CONT DIP-SLDR	28480	1200-0681
A2P3	1251-6786	5	1	CONNECTOR-SINGLE CONTACT .02	28480	1251-6786
A2Q1	1853-0442	4	5	TRANSISTOR PNP 2N3867 SI TO-5 PD=1W	04713	2N3867
A2Q2	1853-0442	4		TRANSISTOR PNP 2N3867 SI TO-5 PD=1W	04713	2N3867
A2Q3	1853-0442	4		TRANSISTOR PNP 2N3867 SI TO-5 PD=1W	04713	2N3867
A2Q4	1853-0442	4		TRANSISTOR PNP 2N3867 SI TO-5 PD=1W	04713	2N3867
A2Q5	1853-0442	4		TRANSISTOR PNP 2N3867 SI TO-5 PD=1W	04713	2N3867
A2Q6	1854-0477	7	17	TRANSISTOR NPN 2N2222A SI TO-18 PD=500MW	04713	2N2222A
A2Q7	1854-0477	7		TRANSISTOR NPN 2N2222A SI TO-18 PD=500MW	04713	2N2222A
A2Q8	1854-0477	7		TRANSISTOR NPN 2N2222A SI TO-18 PD=500MW	04713	2N2222A
A2Q9	1854-0477	7		TRANSISTOR NPN 2N2222A SI TO-18 PD=500MW	04713	2N2222A
A2Q10	1854-0477	7		TRANSISTOR NPN 2N2222A SI TO-18 PD=500MW	04713	2N2222A
A2Q11	1854-0477	7		TRANSISTOR NPN 2N2222A SI TO-18 PD=500MW	04713	2N2222A
A2Q12	1854-0477	7		TRANSISTOR NPN 2N2222A SI TO-18 PD=500MW	04713	2N2222A
A2Q13	1854-0477	7		TRANSISTOR NPN 2N2222A SI TO-18 PD=500MW	04713	2N2222A
A2Q14	1854-0477	7		TRANSISTOR NPN 2N2222A SI TO-18 PD=500MW	04713	2N2222A
A2Q15	1854-0477	7		TRANSISTOR NPN 2N2222A SI TO-18 PD=500MW	04713	2N2222A
A2Q16	1854-0477	7		TRANSISTOR NPN 2N2222A SI TO-18 PD=500MW	04713	2N2222A
A2Q17	1854-0477	7		TRANSISTOR NPN 2N2222A SI TO-18 PD=500MW	04713	2N2222A
A2Q18	1854-0477	7		TRANSISTOR NPN 2N2222A SI TO-18 PD=500MW	04713	2N2222A
A2Q19	1854-0477	7		TRANSISTOR NPN 2N2222A SI TO-18 PD=500MW	04713	2N2222A
A2Q20	1854-0477	7		TRANSISTOR NPN 2N2222A SI TO-18 PD=500MW	04713	2N2222A
A2Q21	1854-0477	7		TRANSISTOR NPN 2N2222A SI TO-18 PD=500MW	04713	2N2222A
A2Q22	1854-0477	7		TRANSISTOR NPN 2N2222A SI TO-18 PD=500MW	04713	2N2222A
A2R1	0757-0416	7	3	RESISTOR 511 1% .125W P TC=0+100	24546	C4-1/8-T0-511R-F
A2R2	0757-0279	0	4	RESISTOR 3.16K 1% .125W P TC=0+100	24546	C4-1/8-T0-3161-F
A2R3	0757-0416	7		RESISTOR 511 1% .125W P TC=0+100	24546	C4-1/8-T0-511R-F
A2R4	0757-0279	0		RESISTOR 3.16K 1% .125W P TC=0+100	24546	C4-1/8-T0-3161-F
A2R5	0757-0416	7		RESISTOR 511 1% .125W P TC=0+100	24546	C4-1/8-T0-511R-F
A2R6	0757-0279	0		RESISTOR 3.16K 1% .125W P TC=0+100	24546	C4-1/8-T0-3161-F
A2R7	0698-3132	4	1	RESISTOR 261 1% .125W P TC=0+100	24546	C4-1/8-T0-2610-F
A2R8	0698-0084	9	1	RESISTOR 2.15K 1% .125W P TC=0+100	24546	C4-1/8-T0-2151-F
A2R9	0757-0279	0		RESISTOR 3.16K 1% .125W P TC=0+100	24546	C4-1/8-T0-3161-F
A2R10		0		NOT ASSIGNED		
A2R11	0698-3446	3	3	RESISTOR 383 1% .125W P TC=0+100	24546	C4-1/8-T0-383R-F
A2R12	0698-3441	8	3	RESISTOR 215 1% .125W P TC=0+100	24546	C4-1/8-T0-215R-F
A2R13	0698-3447	4	5	RESISTOR 422 1% .125W P TC=0+100	24546	C4-1/8-T0-422R-F
A2R14	0698-3447	4		RESISTOR 422 1% .125W P TC=0+100	24546	C4-1/8-T0-422R-F
A2R15	0698-3447	4		RESISTOR 422 1% .125W P TC=0+100	24546	C4-1/8-T0-422R-F
A2R16	0698-3447	4		RESISTOR 422 1% .125W P TC=0+100	24546	C4-1/8-T0-422R-F
A2R17	0757-0419	0	2	RESISTOR 681 1% .125W P TC=0+100	24546	C4-1/8-T0-681R-F
A2R18	0698-3441	8		RESISTOR 215 1% .125W P TC=0+100	24546	C4-1/8-T0-215R-F
A2R19	0698-3447	4		RESISTOR 422 1% .125W P TC=0+100	24546	C4-1/8-T0-422R-F
A2R20	0698-3446	3		RESISTOR 383 1% .125W P TC=0+100	24546	C4-1/8-T0-383R-F

See introduction to this section for ordering information
 *Indicates factory selected value

Table 6-3. Model 8340A Replaceable Parts

Reference Designation	HP Part Number	C D	Qty	Description	Mfr Code	Mfr Part Number
A2R21	0757-0419	0		RESISTOR 681 1% .125W F TC=0+100	24546	C4-1/8-T0-681R-F
A2R22	0698-3441	8		RESISTOR 215 1% .125W F TC=0+100	24546	C4-1/8-T0-215R-F
A2R23	0698-3446	3		RESISTOR 383 1% .125W F TC=0+100	24546	C4-1/8-T0-383R-F
A2R24	0698-7193	5	8	RESISTOR 16.2 1% .05W F TC=0+100	24546	C3-1/8-T0-16R2-F
A2R25	0698-7193	5		RESISTOR 16.2 1% .05W F TC=0+100	24546	C3-1/8-T0-16R2-F
A2R26	0698-7193	5		RESISTOR 16.2 1% .05W F TC=0+100	24546	C3-1/8-T0-16R2-F
A2R27	0698-7193	5		RESISTOR 16.2 1% .05W F TC=0+100	24546	C3-1/8-T0-16R2-F
A2R28	0698-7193	5		RESISTOR 16.2 1% .05W F TC=0+100	24546	C3-1/8-T0-16R2-F
A2R29	0698-7193	5		RESISTOR 16.2 1% .05W F TC=0+100	24546	C3-1/8-T0-16R2-F
A2R30	0698-7193	5		RESISTOR 16.2 1% .05W F TC=0+100	24546	C3-1/8-T0-16R2-F
A2R31	0698-7193	5		RESISTOR 16.2 1% .05W F TC=0+100	24546	C3-1/8-T0-16R2-F
A2R32	0698-3274	5	1	RESISTOR 10K 1% .125W F TC=0+25	28480	0698-3274
A2R33	0698-7244	7	8	RESISTOR 2.15K 1% .05W F TC=0+100	24546	C3-1/8-T0-2151-F
A2R34	0698-7244	7		RESISTOR 2.15K 1% .05W F TC=0+100	24546	C3-1/8-T0-2151-F
A2R35	0698-7244	7		RESISTOR 2.15K 1% .05W F TC=0+100	24546	C3-1/8-T0-2151-F
A2R36	0698-7244	7		RESISTOR 2.15K 1% .05W F TC=0+100	24546	C3-1/8-T0-2151-F
A2R37	0698-7244	7		RESISTOR 2.15K 1% .05W F TC=0+100	24546	C3-1/8-T0-2151-F
A2R38	0698-7244	7		RESISTOR 2.15K 1% .05W F TC=0+100	24546	C3-1/8-T0-2151-F
A2R39	0698-7244	7		RESISTOR 2.15K 1% .05W F TC=0+100	24546	C3-1/8-T0-2151-F
A2R40	0698-7244	7		RESISTOR 2.15K 1% .05W F TC=0+100	24546	C3-1/8-T0-2151-F
A2TP1	0360-2050	8	7	TERMINAL TEST POINT PCB	28480	0360-2050
A2TP2	0360-2050	8		TERMINAL TEST POINT PCB	28480	0360-2050
A2TP3	0360-2050	8		TERMINAL TEST POINT PCB	28480	0360-2050
A2TP4	0360-2050	8		TERMINAL TEST POINT PCB	28480	0360-2050
A2TP5	0360-2050	8		TERMINAL TEST POINT PCB	28480	0360-2050
A2TP6	0360-2050	8		TERMINAL TEST POINT PCB	28480	0360-2050
A2TP7	0360-2050	8		TERMINAL TEST POINT PCB	28480	0360-2050
A2U1	1810-0364	9	1	NETWORK-RES 6-SIP470.0 OHM X 5	01121	206A471
A2U2	1810-0340	1	1	NETWORK-RES 10-SIP24.0 OHM X 5	01121	210B240
A2U3	1820-2266	5	1	IC DRVR TTL	18324	NE590F
A2U4	1820-1226	5	3	IC SHF-RGTR TTL ASYNCHRO SERIAL-IN	28480	1820-1226
A2U5	1820-1226	5		IC SHF-RGTR TTL ASYNCHRO SERIAL-IN	28480	1820-1226
A2U6	1810-0374	1	2	NETWORK-RES 8-SIP1.0K OHM X 4	01121	208B102
A2U7	1810-0374	1		NETWORK-RES 8-SIP1.0K OHM X 4	01121	208B102
A2U8	1820-1226	5		IC SHF-RGTR TTL ASYNCHRO SERIAL-IN	28480	1820-1226
A2U9	1820-1729	3	1	IC LCH TTL LS COM CLEAR 8-BIT	01295	SN74LS259N
A2U10	08340-60017	8	3	MATCHED DISPLAY SET	28480	08340-60017
A2U11	08340-60017	8		MATCHED DISPLAY SET	28480	08340-60017
A2U12	08340-60017	8		MATCHED DISPLAY SET (MUST BE ORDERED AS A SET, MATCHED FOR LUMINOUS INTENSITY)	28480	08340-60017
A2VR1	1902-3036	3	3	DIODE-ZNR 3.16V 5% DO-7 PD=.4W TC=-.064%	28480	1902-3036
A2VR2	1902-3036	3		DIODE-ZNR 3.16V 5% DO-7 PD=.4W TC=-.064%	28480	1902-3036
A2VR3	1902-3036	3		DIODE-ZNR 3.16V 5% DO-7 PD=.4W TC=-.064%	28480	1902-3036
A2VR4	1902-0064	1	1	DIODE-ZNR 7.5V 5% DO-35 PD=.4W TC=+.05%	28480	1902-0064

See introduction to this section for ordering information
 *Indicates factory selected value

Table 6-3. Replaceable Parts

Reference Designation	HP Part Number	C D	Qty	Description	Mfr Code	Mfr Part Number
A3	08340-6000B	7	1	DISPLAY PROCESSOR ASSEMBLY	28480	08340-6000B
A3C1	0160-3875	3	2	CAPACITOR-FXD 22PF +-5% 200VDC CER 0+-30	28480	0160-3875
A3C2	0160-3875	3		CAPACITOR-FXD 22PF +-5% 200VDC CER 0+-30	28480	0160-3875
A3C3	0180-0552	9	1	CAPACITOR-FXD 220UF+-20% 10VDC TA	28480	0180-0552
A3C4	0160-2055	9	3	CAPACITOR-FXD .01UF +80-20% 100VDC CER	28480	0160-2055
A3C5	0160-2055	9		CAPACITOR-FXD .01UF +80-20% 100VDC CER	28480	0160-2055
A3C6	0160-4841	5	1	CAPACITOR-FXD .1UF +80 -20% 50VDC CER	28480	0160-4841
A3C7	0160-2055	9		CAPACITOR-FXD .01UF +80-20% 100VDC CER	28480	0160-2055
A3C8	0160-4084	8	4	CAPACITOR-FXD .1UF +-20% 50VDC CER	28480	0160-4084
A3C9				NOT ASSIGNED		
A3C10	0180-0228	6	2	CAPACITOR-FXD 22UF+-10% 15VDC TA	56289	150D226X901'
A3C11	0180-0116	1	1	CAPACITOR-FXD 6.8UF+-10% 35VDC T A	56289	150D685X9035B2
A3C12	0160-4084	8		CAPACITOR-FXD .1UF +-20% 50VDC CER	28480	0160-4084
A3C13	0180-0228	6		CAPACITOR-FXD 22UF+-10% 15VDC TA	56289	150D226X9015B2
A3C14	0160-4084	8		CAPACITOR-FXD .1UF +-20% 50VDC CER	28480	0160-4084
A3C15	0180-3240	8	5	CAPACITOR-AL 220 UF 10VDC	28480	0180-3240
A3C16	0180-3240	8		CAPACITOR-AL 220 UF 10VDC	28480	0180-3240
A3C17	0180-3240	8		CAPACITOR-AL 220 UF 10VDC	28480	0180-3240
A3C18	0180-3240	8		CAPACITOR-AL 220 UF 10VDC	28480	0180-3240
A3C19	0180-3240	8		CAPACITOR-AL 220 UF 10VDC	28480	0180-3240
A3C20	0180-0291	3	1	CAPACITOR-FXD 1UF+-10% 35VDC TA	56289	150D105X9035A2
A3C21	0160-3879	7	2	CAPACITOR-FXD .01UF +-20% 100VDC CER	28480	0160-3879
A3C22	0160-3879	7		CAPACITOR-FXD .01UF +-20% 100VDC CER	28480	0160-3879
A3C23	0160-4084	8		CAPACITOR-FXD .1UF +-20% 50VDC CER	28480	0160-4084
A3CR1	1901-0033	2	2	DIODE-GEN PRP 180V 200MA DO-7	28480	1901-0033
A3CR2	1901-0033	2		DIODE-GEN PRP 180V 200MA DO-7	28480	1901-0033
A3J1	1251-6787	6	1	SOCKET STRIP-6 CONTACT	28480	1251-6787
A3J2	1251-5746	5	1	CONNECTOR 50-PIN M POST TYPE	28480	1251-5746
A3L1				NOT ASSIGNED		
A3L2	08340-80001	2	1	COIL-TOROID	28480	08340-80001
A3L3	9100-1788	6	2	CHOKE-WIDE BAND ZMAX=680 OHM@ 180 MHZ	02114	VK200 20/48
A3L4	9100-1788	6		CHOKE-WIDE BAND ZMAX=680 OHM@ 180 MHZ	02114	VK200 20/48
A3MP1	0340-0162	7	1	INSULATOR-XSTR ALUMINUM	28480	0340-0162
A3MP2	0590-0526	6	1	INSERT-NB 4-40	28480	0590-0526
A3MP3				NOT ASSIGNED		
A3MP4	1205-0085	8	1	HEAT SINK TO-66-CS	28480	1205-0085
A3MP5	2200-0105	4	2	SCREW-MACH 4-40 .312-IN-LG PAN-HD-POZI	00000	ORDER BY DESCRIPTION
A3MP6	2200-0105	4		SCREW-MACH 4-40 .312-IN-LG PAN-HD-POZI	00000	ORDER BY DESCRIPTION
				NOTE		
				HP Part Number 1251-6798 (A3P1-5) must be cut to length prior to replacement.		
A3P1	1251-6798	9	5	CONNECTOR-PC 36 MALE IR	28480	1251-6798
A3P2	1251-6798	9		CONNECTOR-PC 36 MALE IR	28480	1251-6798
A3P3	1251-6798	9		CONNECTOR-PC 36 MALE IR	28480	1251-6798
A3P4	1251-6798	9		CONNECTOR-PC 36 MALE IR	28480	1251-6798
A3P5	1251-6798	9		CONNECTOR-PC 36 MALE IR	28480	1251-6798
A3Q1	1853-0413	9	1	TRANSISTOR PNP 2N6049 SI TO-66 PD=75W	28480	1853-0413
A3Q2	1853-0281	9	1	TRANSISTOR PNP 2N2907A SI TO-18 PD=400MW	04713	2N2907A
A3R1	0757-0260	3	1	RESISTOR 1K 1% .125W F TC=0+-100	24546	C4-1/8-T0-1001-F
A3R2	0698-7267	7	2	RESISTOR 10K 1% .05W F TC=0+-100	24546	C3-1/8-T0-1002-F
A3R3	0698-315J	5	1	RESISTOR 26.1K 1% .125W F TC=0+-100	24546	C4-1/8-T0-2612-F
A3R4	0698-3396	2	1	RESISTOR 38.3 1% .5W F TC=0+-100	28480	0698-3396
A3R5	0811-1553	1	1	RESISTOR .68 5% 2W PW TC=0+-800	75042	BWH2-11/16-J
A3R6	0811-1666	7	1	RESISTOR 1 5% 2W PW TC=0+-800	75042	BWH2-1R0-J
A3R7				NOT ASSIGNED		
A3R8	0757-0438	3	1	RESISTOR 5.11K 1% .125W F TC=0+-100	24546	C4-1/8-T0-5111-F
A3R9	0757-0458	7	4	RESISTOR 51.1K 1% .125W F TC=0+-100	24546	C4-1/8-T0-5112-F
A3R10	0698-3160	8	1	RESISTOR 31.6K 1% .125W F TC=0+-100	24546	C4-1/8-T0-3162-F
A3R11	0757-0458	7		RESISTOR 51.1K 1% .125W F TC=0+-100	24546	C4-1/8-T0-5112-F
A3R12	0698-3150	6	1	RESISTOR 2.37K 1% .125W F TC=0+-100	24546	C4-1/8-T0-2371-F
A3R13	0757-0442	9	1	RESISTOR 10K 1% .125W F TC=0+-100	24546	C4-1/8-T0-1002-F
A3R14	0757-0458	7		RESISTOR 51.1K 1% .125W F TC=0+-100	24546	C4-1/8-T0-5112-F
A3R15	0757-0458	7		RESISTOR 51.1K 1% .125W F TC=0+-100	24546	C4-1/8-T0-5112-F
A3R16	0698-7260	7		RESISTOR 10K 1% .05W F TC=0+-100	24546	C3-1/8-T0-1002-F
A3TP1-8				NOT ASSIGNED		
A3TP9	0360-2050	8	0	TERMINAL TEST POINT, PCB	28480	0360-2050
A3TP10	0360-2050	8		TERMINAL TEST POINT, PCB	28480	0360-2050
A3TP11	0360-2050	8		TERMINAL TEST POINT, PCB	28480	0360-2050
A3TP12	0360-2050	8		TERMINAL TEST POINT, PCB	28480	0360-2050
A3TP13	0360-2050	8		TERMINAL TEST POINT, PCB	28480	0360-2050
A3TP14	0360-2050	8		TERMINAL TEST POINT, PCB	28480	0360-2050
A3TP15	0360-2050	8		TERMINAL TEST POINT, PCB	28480	0360-2050
A3TP16	0360-2050	8		TERMINAL TEST POINT, PCB	28480	0360-2050
A3U1	1820-2865	0	1	IC-8-BIT MICROCOMPUTER; 11MHz/4Z OPERATION	28480	1820-2865

See Introduction to this section for ordering information.

*Indicates factory related value.

Table 6-3. Replaceable Parts

Reference Designation	HP Part Number	C D	Qty	Description	Mfr Code	Mfr Part Number
A3U2	1820-1975	1	1	IC SHF-RGTR TTL LS NEG-EDGE-TRIG PRL-IN	01295	SN74LS165N
A3U3	1820-1287	8	1	IC BFR TTL LS NAND QUAD 2-INP	01295	SN74LS37N
A3U4	1820-0668	7	2	IC BFR TTL NON-INV HEX 1-INP	01295	SN7407N
A3U5	1820-1196	8	2	IC FF TTL LS D-TYPE POS-EDGE-TRIG COM	01295	SN74LS174N
A3U6	1820-1997	7	1	IC FF TTL LS D-TYPE POS-EDGE-TRIG PRL-IN	01295	SN74LS374N
A3U7	1820-1196	8	1	IC FF TTL LS D-TYPE POS-EDGE-TRIG COM	01295	SN74LS174N
A3U8	1820-0668	7	1	IC BFR TTL NON-INV HEX 1-INP	01295	SN7407N
A3U9	1820-1425	6	1	IC SCHMITT-TRIG TTL LS NAND QUAD 2-INP	01295	SN74LS132N
A3U10	1820-1216	3	1	IC DCDR TTL LS 3-TO-8-LINE 3-INP	01295	SN74LS138N
A3U11	1826-0161	7	1	IC OP AMP GP QUAD 14-DIP-P PKG	04713	MLM324P
A3U12	1810-0398	9	1	NETWORK-RES 10-SIP22.0K OHM X 9	11236	750-101-R22K
A3VR1	1902-1359	9	1	DIODE-ZNR 4.3V 2% PD=5W IR=10UA	28480	1902-1359
A3Y1	0410-1295	8	1	CRYSTAL-10.92 MHZ	28480	0410-1295

See introduction to this section for ordering information.

*Indicates factory selected value.

Table 6-3. Model 8340A Replaceable Parts

Reference Designation	HP Part Number	C D	Qty	Description	Mfr Code	Mfr Part Number
A4				NOT ASSIGNED		
A5	08340-60010	1	1	KEYBOARD	28480	08340-60010
A5DS1	1990-0858	6	18	L.E.D. (YELLOW) 150 UCD	28480	1990-0858
A5DS2	1990-0858	6		L.E.D. (YELLOW) 150 UCD	28480	1990-0858
A5DS3	1990-0857	5	1	L.E.D. (GREEN) 150 UCD	28480	1990-0857
A5DS4	1990-0858	6		L.E.D. (YELLOW) 150 UCD	28480	1990-0858
A5DS5	1990-0858	6		L.E.D. (YELLOW) 150 UCD	28480	1990-0858
A5DS6	1990-0858	6		L.E.D. (YELLOW) 150 UCD	28480	1990-0858
A5DS7	1990-0858	6		L.E.D. (YELLOW) 150 UCD	28480	1990-0858
A5DS8	1990-0858	6		L.E.D. (YELLOW) 150 UCD	28480	1990-0858
A5DS9	1990-0858	6		L.E.D. (YELLOW) 150 UCD	28480	1990-0858
A5DS10	1990-0858	6		L.E.D. (YELLOW) 150 UCD	28480	1990-0858
A5DS11	1990-0858	6		L.E.D. (YELLOW) 150 UCD	28480	1990-0858
A5DS12	1990-0858	6		L.E.D. (YELLOW) 150 UCD	28480	1990-0858
A5DS13	1990-0858	6		L.E.D. (YELLOW) 150 UCD	28480	1990-0858
A5DS14	1990-0858	6		L.E.D. (YELLOW) 150 UCD	28480	1990-0858
A5DS15	1990-0858	6		L.E.D. (YELLOW) 150 UCD	28480	1990-0858
A5DS16	1990-0858	6		L.E.D. (YELLOW) 150 UCD	28480	1990-0858
A5DS17	1990-0856	4	2	L.E.D. (RED) 150 UCD	28480	1990-0856
A5DS18	1990-0856	4		L.E.D. (RED) 150 UCD	28480	1990-0856
A5DS19				NOT ASSIGNED		
A5DS20	1990-0858	6		L.E.D. (YELLOW) 150 UCD	28480	1990-0858
A5DS21	1990-0858	6		L.E.D. (YELLOW) 150 UCD	28480	1990-0858
A5DS22	1990-0858	6		L.E.D. (YELLOW) 150 UCD	28480	1990-0858
A5J1	1251-6799	0	1	CONNECTOR HEADER 36 MIR	28480	1251-6799
A5J2	1251-6787	6	2	SOCKET STRIP-6 CONTACT	28480	1251-6787
A5J3	1251-6787	6		SOCKET STRIP-6 CONTACT	28480	1251-6787
A5MP1	0590-0526	6	1	THREADED INSERT-NUT 4-40 .065-IN-LG SST	28480	0590-0526
A5MP2	5041-2732	2	1	KEY CAP "CONT"	28480	5041-2732
A5MP3	5041-2735	5	1	KEY CAP "FREE RUN"	28480	5041-2735
A5MP4	5041-2738	8	1	KEY CAP "LOCAL"	28480	5041-2738
A5MP5	5041-2733	3	1	KEY CAP "SINGLE"	28480	5041-2733
A5MP6	5041-2736	6	1	KEY CAP "LINE"	28480	5041-2736
A5MP7	5041-2739	9	1	KEY CAP "SAVE"	28480	5041-2739
A5MP8	5041-2734	4	1	KEY CAP "MANUAL"	28480	5041-2734
A5MP9	5041-2737	7	1	KEY CAP "EXT"	28480	5041-2737
A5MP10	5041-2731	1	1	KEY CAP "ALT"	28480	5041-2731
A5MP11	5041-2740	2	1	KEY CAP "RECALL"	28480	5041-2740
A5MP12	5041-2712	8	1	KEY CAP "M1"	28480	5041-2712
A5MP13	5041-2713	9	1	KEY CAP "M2"	28480	5041-2713
A5MP14	5041-2725	3	1	KEY CAP "MKR SWP"	28480	5041-2725
A5MP15	5041-0720	4	1	KEY CAP "INST PREST"	28480	5041-0720
A5MP16	5041-2714	0	1	KEY CAP "M3"	28480	5041-2714
A5MP17	5041-0692	9	1	KEY CAP "OFF"	28480	5041-0692
A5MP18	5041-2715	1	1	KEY CAP "M4"	28480	5041-2715
A5MP19	5041-2718	4	1	KEY CAP "MKR DELTA"	28480	5041-2718
A5MP20	5041-2729	7	1	KEY CAP "PULSE"	28480	5041-2729
A5MP21	5041-2716	2	1	KEY CAP "M5"	28480	5041-2716
A5MP22	5041-2726	4	1	KEY CAP "MKR TO CF"	28480	5041-2726
A5MP23	5041-2748	0	1	KEY CAP "AM"	28480	5041-2748
A5MP24	5041-2748	0	1	KEY CAP "ENTRY OFF"	28480	5041-2748
A5MP25	5041-2748	0	2	KEY CAP "ARROW DOWN"	28480	5041-2747
A5MP26	5041-2748	0		KEY CAP "ARROW UP"	28480	5041-2747
A5MP27	5041-2719	5	1	KEY CAP "START FREQ"	28480	5041-2719
A5MP28	5041-2721	9	1	KEY CAP "CF"	28480	5041-2721
A5MP29	5041-2724	2	1	KEY CAP "CW"	28480	5041-2724
A5MP30	5041-2727	5	1	KEY CAP "SWEEP TIME"	28480	5041-2727
A5MP31	5041-2720	8	1	KEY CAP "STOP FREQ"	28480	5041-2720
A5MP32	5041-2722	0	1	KEY CAP "DELTA FREQ"	28480	5041-2722
A5MP33	5041-2723	1	1	KEY CAP "PWR LVL"	28480	5041-2723
A5MP34	5041-2745	7	1	KEY CAP "SHIFT"	28480	5041-2745
A5MP35	5041-0643	0	1	KEY CAP "7"	28480	5041-0643
A5MP36	5041-0640	7	1	KEY CAP "4"	28480	5041-0640
A5MP37	5041-0637	2	1	KEY CAP "1"	28480	5041-0637
A5MP38	5041-0646	3	1	KEY CAP "0"	28480	5041-0646
A5MP39	5041-0644	1	1	KEY CAP "8"	28480	5041-0644
A5MP40	5041-0641	8	1	KEY CAP "5"	28480	5041-0641
A5MP41	5041-0638	3	1	KEY CAP "2"	28480	5041-0638
A5MP42	5041-0647	4	1	KEY CAP "DECIMAL"	28480	5041-0647
A5MP43	5041-0645	2	1	KEY CAP "9"	28480	5041-0645
A5MP44	5041-2747	9	1	KEY CAP "6"	28480	5041-2747
A5MP45	5041-0639	4	1	KEY CAP "3"	28480	5041-0639

See introduction to this section for ordering information
 *Indicates factory selected value

Table 6-3. Replaceable Parts

Reference Designation	HP Part Number	C D	Qty	Description	Mfr Code	Mfr Part Number
A5MP46	5041-2747	9	1	KEY CAP "BACK SPACE"	28480	5041-2748
A5MP47	5041-2741	3	1	KEY CAP "GHZ/DB(M)"	28480	5041-2741
A5MP48	5041-2742	4	1	KEY CAP "MHZ/SEC)"	28480	5041-2742
A5MP49	5041-2743	5	1	KEY CAP "KHZ/MSEC)"	28480	5041-2743
A5MP50	5041-2744	6	.1	KEY CAP "HZ AUTO"	28480	5041-2744
A5MP51	5040-8858	3	21	LED STDF STRP, 2 PER	28480	5040-8858
A5R1	0757-0416	7	1	RESISTOR 511 1% .125W F TC=0+100	24546	C4-1/8-T0-511R-F
A5R2	0757-0428	1	2	RESISTOR 1.62K 1% .125W F TC=0+100	24546	C4-1/8-T0-1621-F
A5R3	0757-0428	1		RESISTOR 1.62K 1% .125W F TC=0+100	24546	C4-1/8-T0-1621-F
A5S1 - 39	5060-9436	7	49	PUSHBUTTON SWITCH P.C. MOUNT	28480	5060-9436
A5S40				NOT ASSIGNED		
A5S41	5060-9436	7		PUSHBUTTON SWITCH P.C. MOUNT	28480	5060-9436
A5S42	5060-9436	7		PUSHBUTTON SWITCH P.C. MOUNT	28480	5060-9436
A5S43	5060-9436	7		PUSHBUTTON SWITCH P.C. MOUNT	28480	5060-9436
A5S44	5060-9436	7		PUSHBUTTON SWITCH P.C. MOUNT	28480	5060-9436
A5S45	5060-9436	7		PUSHBUTTON SWITCH P.C. MOUNT	28480	5060-9436
A5S46	5060-9436	7		PUSHBUTTON SWITCH P.C. MOUNT	28480	5060-9436
A5S47	5060-9436	7		PUSHBUTTON SWITCH P.C. MOUNT	28480	5060-9436
A5S48	5060-9436	7		PUSHBUTTON SWITCH P.C. MOUNT	28480	5060-9436
A5S49	5060-9436	7		PUSHBUTTON SWITCH P.C. MOUNT	28480	5060-9436
A5S50	5060-9436	7		PUSHBUTTON SWITCH P.C. MOUNT	28480	5060-9436
A5U1	1810-0203	5	3	NETWORK-RES 8-SIP 470.0 OHM X 7	01121	208A471
A5U2	1810-0203	5		NETWORK-RES 8-SIP 470.0 OHM X 7	01121	208A471
A5U3	1810-0203	5		NETWORK-RES 8-SIP 470.0 OHM X 7	01121	208A471

See introduction to this section for ordering information
 *Indicates factory selected value

Table 6-3. Model 8340A Replaceable Parts

Reference Designation	HP Part Number	C D	Qty	Description	Mfr Code	Mfr Part Number
A6	08340-60011	2	1	KEYBOARD INTERFACE	28480	08340-60011
A6C1	0180-0197	8	2	CAPACITOR-FXD 2.2UF+10% 20VDC TA	56289	150D225X9020A2
A6C2	0160-2055	9	10	CAPACITOR-FXD .01UF +80-20% 100VDC CER	28480	0160-2055
A6C3	0160-2055	9		CAPACITOR-FXD .01UF +80-20% 100VDC CER	28480	0160-2055
A6C4	0160-2055	9		CAPACITOR-FXD .01UF +80-20% 100VDC CER	28480	0160-2055
A6C5	0160-4084	8	7	CAPACITOR-FXD .1UF +20% 50VDC CER	28480	0160-4084
A6C6	0160-4084	8		CAPACITOR-FXD .1UF +20% 50VDC CER	28480	0160-4084
A6C7	0180-0116	7	1	CAPACITOR-FXD 6.8UF+10% 35VDC TA	56289	150D685X9035B2
A6C8	0160-0162	5	1	CAPACITOR-FXD .022UF +10% 200VDC POLYE	28480	0160-0162
A6C9	0160-4084	8		CAPACITOR-FXD .1UF +20% 50VDC CER	28480	0160-4084
A6C10	0160-4084	8		CAPACITOR-FXD .1UF +20% 50VDC CER	28480	0160-4084
A6C11	0160-2055	9		CAPACITOR-FXD .01UF +80-20% 100VDC CER	28480	0160-2055
A6C12	0160-2055	9		CAPACITOR-FXD .01UF +80-20% 100VDC CER	28480	0160-2055
A6C13	0160-2055	9		CAPACITOR-FXD .01UF +80-20% 100VDC CER	28480	0160-2055
A6C14	0160-2055	9		CAPACITOR-FXD .01UF +80-20% 100VDC CER	28480	0160-2055
A6C15	0160-4084	8		CAPACITOR-FXD .1UF +20% 50VDC CER	28480	0160-4084
A6C16	0160-4084	8		CAPACITOR-FXD .1UF +20% 50VDC CER	28480	0160-4084
A6C17	0180-0291	3	1	CAPACITOR-FXD 1UF+10% 35VDC TA	56289	150D105X9035A2
A6C18	0180-0228	6	1	CAPACITOR-FXD 22UF+10% 15VDC TA	56289	150D226X9015B2
A6C19	0160-4084	8		CAPACITOR-FXD .1UF +20% 50VDC CER	28480	0160-4084
A6C20	0160-2055	9		CAPACITOR-FXD .01UF +80-20% 100VDC CER	28480	0160-2055
A6C21	0160-2055	9		CAPACITOR-FXD .01UF +80-20% 100VDC CER	28480	0160-2055
A6C22	0180-0197	8		CAPACITOR-FXD 2.2UF+10% 20VDC TA	56289	150D225X9020A2
A6C23	0160-2055	9		CAPACITOR-FXD .01UF +80-20% 100VDC CER	28480	0160-2055
A6C24	0180-2731	0	1	CAPACITOR-FXD 2.2UF+10% 20VDC TA	28480	0180-2731
A6C25	0160-3879	7	4	CAPACITOR-FXD .01UF +20% 100VDC CER	28480	0160-3879
A6C26	0160-3879	7		CAPACITOR-FXD .01UF +20% 100VDC CER	28480	0160-3879
A6C27	0160-3879	7		CAPACITOR-FXD .01UF +20% 100VDC CER	28480	0160-3879
A6C28	0160-3879	7		CAPACITOR-FXD .01UF +20% 100VDC CER	28480	0160-3879
A6CR1	1901-0050	3	1	DIODE-SWITCHING 80V 200MA 2NS DO-35	28480	1901-0050
A6CR2	1901-0518	8	2	DIODE-SM SIG SCHOTTKY	28480	1901-0518
A6CR3	1901-0518	8		DIODE-SM SIG SCHOTTKY	28480	1901-0518
A6J1	1251-4634	8	2	CONNECTOR HEADER 20 M2R	28480	1251-4634
A6J2	1251-6868	4	1	CONNECTOR HEADER 5 M IR	28480	1251-6868
A6J3	1251-5746	5	1	CONNECTOR HEADER 50 M2R	28480	1251-5746
A6J4	1251-6793	4	1	CONNECTOR HEADER 3 M IR	28480	1251-6793
A6L1	9100-1788	6	1	CHOKE-WIDE BAND ZMAX=680 OHM@ 180 MHZ	02114	VK200 20/48
A6MP1	0380-0043	7	6	SPACER-RVT-ON .375-IN-LG .14-IN-ID	28480	0380-0043
A6MP2	0380-0043	7		SPACER-RVT-ON .375-IN-LG .14-IN-ID	28480	0380-0043
A6MP3	0380-0043	7		SPACER-RVT-ON .375-IN-LG .14-IN-ID	28480	0380-0043
A6MP4				NOT ASSIGNED		
A6MP5	0380-0043	7		SPACER-RVT-ON .375-IN-LG .14-IN-ID	28480	0380-0043
A6MP6	0380-0043	7		SPACER-RVT-ON .375-IN-LG .14-IN-ID	28480	0380-0043
A6MP7	0380-0111	0	1	STANDOFF-RVT-ON .25-IN-LG 6-32THD	00000	ORDER BY DESCRIPTION
A6P1	1251-6787	6	5	SOCKET STRIP 6 CONTACT	28480	1251-6787
A6P2	1251-6799	0	2	CONNECTOR HEADER 36 M IR	28480	1251-6799
A6P3	1251-6799	0		CONNECTOR HEADER 36 M IR	28480	1251-6799
A6R1	0683-6855	3	1	RESISTOR 6.8M 5% .25W FC TC=-900/+1100	01121	CB6855
A6R2	0757-0280	3	1	RESISTOR 1K 1% .125W F TC=0+100	24546	C4-1/8-T0-1001-F
A6R3	0757-0464	5	1	RESISTOR 90.9K 1% .125W F TC=0+100	03292	C4-1/8-T0-9092-F
A6R4	0698-3155	1	2	RESISTOR 4.64K 1% .125W F TC=0+100	24546	C4-1/8-T0-4641-F
A6R5	0698-3449	6	1	RESISTOR 28.7K 1% .125W F TC=0+100	24546	C4-1/8-T0-2872-F
A6R6	0698-3162	0	1	RESISTOR 46.4K 1% .125W F TC=0+100	24546	C4-1/8-T0-4642-F
A6R7	0757-0123	3	1	RESISTOR 34.8K 1% .125W F TC=0+100	28480	0757-0123
A6R8	0757-0442	9	1	RESISTOR 10K 1% .125W F TC=0+100	24546	C4-1/8-T0-1002-F
A6R9	0757-0438	3	3	RESISTOR 5.11K 1% .125W F TC=0+100	24546	C4-1/8-T0-5111-F
A6R10	0757-0438	3		RESISTOR 5.11K 1% .125W F TC=0+100	24546	C4-1/8-T0-5111-F
A6R11	0757-0438	3		RESISTOR 5.11K 1% .125W F TC=0+100	24546	C4-1/8-T0-5111-F
A6R12	0698-3155	1		RESISTOR 4.64K 1% .125W F TC=0+100	24546	C4-1/8-T0-4641-F
A6TP1	0360-0535	0	15	TERMINAL TEST POINT PCB	00000	ORDER BY DESCRIPTION
A6TP2	0360-0535	0		TERMINAL TEST POINT PCB	00000	ORDER BY DESCRIPTION
A6TP3	0360-0535	0		TERMINAL TEST POINT PCB	00000	ORDER BY DESCRIPTION
A6TP4	0360-0535	0		TERMINAL TEST POINT PCB	00000	ORDER BY DESCRIPTION
A6TP5	0360-0535	0		TERMINAL TEST POINT PCB	00000	ORDER BY DESCRIPTION
A6TP6	0360-0535	0		TERMINAL TEST POINT PCB	00000	ORDER BY DESCRIPTION
A6TP7	0360-0535	0		TERMINAL TEST POINT PCB	00000	ORDER BY DESCRIPTION
A6TP8	0360-0535	0		TERMINAL TEST POINT PCB	00000	ORDER BY DESCRIPTION
A6TP9	0360-0535	0		TERMINAL TEST POINT PCB	00000	ORDER BY DESCRIPTION
A6TP10	0360-0535	0		TERMINAL TEST POINT PCB	00000	ORDER BY DESCRIPTION
A6TP11	0360-0535	0		TERMINAL TEST POINT PCB	00000	ORDER BY DESCRIPTION

See introduction to this section for ordering information
 *Indicates factory selected value

Table 6-3. Model 8340A Replaceable Parts

Reference Designation	HP Part Number	C D	Qty	Description	Mfr Code	Mfr Part Number
A6TP12	0360-0535	0		TERMINAL TEST POINT PCB	00000	ORDER BY DESCRIPTION
A6TP13	0360-0535	0		TERMINAL TEST POINT PCB	00000	ORDER BY DESCRIPTION
A6TP14	0360-0535	0		TERMINAL TEST POINT PCB	00000	ORDER BY DESCRIPTION
A6TP15	0360-0535	0		TERMINAL TEST POINT PCB	00000	ORDER BY DESCRIPTION
A6U1	1820-1851	2	2	IC ENCDR TTL LS	01295	SN74LS148N
A6U2	1820-1197	9	1	IC GATE TTL LS NAND QUAD 2-INP	01295	SN74LS00N
A6U3	1820-1272	1	1	IC BFR TTL LS NOR QUAD 2-INP	01295	SN74LS33N
A6U4	1820-1112	8	2	IC FF TTL LS D-TYPE POS-EDGE-TRIG	01295	SN74LS74AN
A6U5	1826-0180	0	1	IC TIMER TTL MONO/ASTBL	01295	NE555P
A6U6	1820-1730	6	4	IC FF TTL LS D-TYPE POS-EDGE-TRIG COM	01295	SN74LS273N
A6U7	1820-1730	6		IC FF TTL LS D-TYPE POS-EDGE-TRIG COM	01295	SN74LS273N
A6U8	1820-1416	5	1	IC SCHMITT-TRIG TTL LS INV HEX 1-INP	01295	SN74LS14N
A6U9	1820-1437	0	1	IC MV TTL LS MONOSTBL DUAL	01698	SN74LS221N
A6U10	1820-1851	2		IC ENCDR TTL LS	01295	SN74LS148N
A6U11	1820-1917	1	1	IC BFR TTL LS LINE DRVR OCTL	01295	SN74LS240N
A6U12	1820-2024	3	1	IC DRVR TTL LS LINE DRVR OCTL	01295	SN74LS244N
A6U13	1820-2270	1	2	IC CNTR TTL LS BIN UP/DOWN SYNCHRO	34335	AM25LS2569DC
A6U14	1820-1144	6	1	IC GATE TTL LS NOR QUAD 2-INP	01295	SN74LS02N
A6U15	1820-1216	3	1	IC DCDR TTL LS 3-TO-8-LINE 3-INP	01295	SN74LS138N
A6U16	1820-1730	6		IC FF TTL LS D-TYPE POS-EDGE-TRIG COM	01295	SN74LS273N
A6U17	1820-1730	6		IC FF TTL LS D-TYPE POS-EDGE-TRIG COM	01295	SN74LS273N
A6U18	1820-2270	1		IC CNTR TTL LS BIN UP/DOWN SYNCHRO	34335	AM25LS2569DC
A6U19	1820-1112	8		IC FF TTL LS D-TYPE POS-EDGE-TRIG	01295	SN74LS74AN
A6U20	1820-1437	0	1	IC MV TTL LS MONOSTBL DUAL	01295	SN74LS221N
A6U21	1810-0280	8	2	NETWORK-RES 10-SIP10.0K OHM X 9	01121	210A103
A6U22	1810-0280	8		NETWORK-RES 10-SIP10.0K OHM X 9	01121	210A103
A6U23	1810-0206	8	1	NETWORK-RES 8-SIP10.0K OHM X 7	01121	208A103

See introduction to this section for ordering information
 *Indicates factory selected value

Table 6-3. Model 8340A Replaceable Parts

Reference Designation	HP Part Number	C D	Qty	Description	Mfr Code	Mfr Part Number
A7	08340-60012	3	1	LOWER KEYBOARD	28480	08340-60012
A7DS1	1990-0670	0	8	L.E.D. (YELLOW) 1 MCD	28480	1990-0670
A7DS2	1990-0670	0		L.E.D. (YELLOW) 1 MCD	28480	1990-0670
A7DS3	1990-0670	0		L.E.D. (YELLOW) 1 MCD	28480	1990-0670
A7DS4	1990-0670	0		L.E.D. (YELLOW) 1 MCD	28480	1990-0670
A7DS5	1990-0670	0		L.E.D. (YELLOW) 1 MCD	28480	1990-0670
A7DS6	1990-0670	0		L.E.D. (YELLOW) 1 MCD	28480	1990-0670
A7DS7	1990-0670	0		L.E.D. (YELLOW) 1 MCD	28480	1990-0670
A7DS8	1990-0670	0		L.E.D. (YELLOW) 1 MCD	28480	1990-0670
A7J1	1251-4634	8		CONNECTOR HEADER 20 M2R	28480	1251-4634
A7MP1	5041-0318	6	8	KEY CAP-QUARTER LT PIPE	28480	5041-0318
A7S1	5060-9436	7	8	PUSHBUTTON SWITCH P.C. MOUNT	28480	5060-9436
A7S2	5060-9436	7		PUSHBUTTON SWITCH P.C. MOUNT	28480	5060-9436
A7S3	5060-9436	7		PUSHBUTTON SWITCH P.C. MOUNT	28480	5060-9436
A7S4	5060-9436	7		PUSHBUTTON SWITCH P.C. MOUNT	28480	5060-9436
A7S5	5060-9436	7		PUSHBUTTON SWITCH P.C. MOUNT	28480	5060-9436
A7S6	5060-9436	7		PUSHBUTTON SWITCH P.C. MOUNT	28480	5060-9436
A7S7	5060-9436	7		PUSHBUTTON SWITCH P.C. MOUNT	28480	5060-9436
A7S8	5060-9436	7		PUSHBUTTON SWITCH P.C. MOUNT	28480	5060-9436
A7U1	1810-0272	8	1	NETWORK-RES 10-SIP330.0 ORM X 9	01121	210A331

See introduction to this section for ordering information
 *Indicates factory selected value

Table 6-3. Model 8340A Replaceable Parts

Reference Designation	HP Part Number	C D	Qty	Description	Mfr Code	Mfr Part Number
A8	5086-7309	3	1	BAND O 3.7 GHZ OSCILLATOR 5086-7309 INCLUDES A8A1 PC BOARD AND A8A2 3.7 GHZ OSCILLATOR MICROCIRCUIT.)	28480	5086-7309
	5086-6309	1	1	EXCHANGE 5086-7309 OSCILLATOR	28480	5086-6309
A8A1	08340-60041	8	2	3.7 GHZ OSCILLATOR PC BOARD	28480	08340-60041
A8A1C1	0160-3874	2	1	CAPACITOR-FXD 10PF \pm .5PF 200VDC CER	28480	0160-3874
A8A1C2	0160-3877	5	2	CAPACITOR-FXD 100PF \pm 20% 200VDC CER	28480	0160-3877
A8A1C3	0180-0291	3	1	CAPACITOR-FXD 1UF \pm 10% 35VDC TA	56289	150D105X9035A2
A8A1C4	0121-0046	2	1	CAPACITOR-V TRMR-CER 9-35PF 200V PC-MTG	52763	304322 9/35PF N650
A8A1C5	0160-3877	5	2	CAPACITOR-FXD 100PF \pm 20% 200VDC CER	28480	0160-3877
A8A1C6	0160-3878	6	7	CAPACITOR-FXD 1000PF \pm 20% 100VDC CER	28480	0160-3878
A8A1C7	0160-3878	6	7	CAPACITOR-FXD 1000PF \pm 20% 100VDC CER	28480	0160-3878
A8A1C8	0160-2150	5	1	CAPACITOR-FXD 33PF \pm 5% 300VDC MICA	28480	0160-2150
A8A1C9	0160-3878	6	7	CAPACITOR-FXD 1000PF \pm 20% 100VDC CER	28480	0160-3878
A8A1C10	0160-3878	6	7	CAPACITOR-FXD 1000PF \pm 20% 100VDC CER	28480	0160-3878
A8A1C11	0160-3878	6	7	CAPACITOR-FXD 1000PF \pm 20% 100VDC CER	28480	0160-3878
A8A1C12	0160-0134	1	1	CAPACITOR-FXD 220PF \pm 5% 300VDC MICA	28480	0160-0134
A8A1C13	0170-0040	9	1	CAPACITOR-FXD .047UF \pm 10% 200VDC POLYME	56289	292P47392
A8A1C14	0180-2904	9	1	CAPACITOR-FXD .1UF \pm 10% 75VDC TA	28480	0180-2904
A8A1C15	0180-2205	3	1	CAPACITOR-FXD .33UF \pm 10% 35VDC TA	56289	150D334X9035A2
A8A1C16	0160-3878	6	7	CAPACITOR-FXD 1000PF \pm 20% 100VDC CER	28480	0160-3878
A8A1C17	0160-3878	6	7	CAPACITOR-FXD 1000PF \pm 20% 100VDC CER	28480	0160-3878
A8A1C18	0160-0574	3	4	CAPACITOR-FXD .022UF \pm 20% 100VDC CER	28480	0160-0574
A8A1C19	0160-0574	3	4	CAPACITOR-FXD .022UF \pm 20% 100VDC CER	28480	0160-0574
A8A1C20	0160-0574	3	4	CAPACITOR-FXD .022UF \pm 20% 100VDC CER	28480	0160-0574
A8A1C21	0160-0574	3	4	CAPACITOR-FXD .022UF \pm 20% 100VDC CER	28480	0160-0574
A8A1C22	0180-0630	4	2	CAPACITOR-FXD 4.7UF \pm 20% 50VDC TA	28480	0180-0630
A8A1CR1	1901-0033	2	6	DIODE-GEN PRP 180V 200MA DO-7	28480	1901-0033
A8A1CR2	1901-0033	2	6	DIODE-GEN PRP 180V 200MA DO-7	28480	1901-0033
A8A1CR3	1901-0033	2	6	DIODE-GEN PRP 180V 200MA DO-7	28480	1901-0033
A8A1CR4	1901-0033	2	6	DIODE-GEN PRP 180V 200MA DO-7	28480	1901-0033
A8A1CR5	1901-0033	2	6	DIODE-GEN PRP 180V 200MA DO-7	28480	1901-0033
A8A1CR6	1901-0033	2	6	DIODE-GEN PRP 180V 200MA DO-7	28480	1901-0033
A8A1E1	1460-1489	8	1	JUMPER .022 LG	28480	1460-1489
A8A1E2	9170-0029	3	2	CORE-SHIELDING BEAD	28480	9170-0029
A8A1E3	9170-0029	3	2	CORE-SHIELDING BEAD	28480	9170-0029
A8A1J1	1250-1611	3	2	CONNECTOR-RF M SMB-PC	28480	1250-1611
A8A1J2	1250-1611	3	2	CONNECTOR-RF M SMB-PC	28480	1250-1611
A8A1L1	9100-2891	4	1	INDUCTOR RF-CH-MLD 50NH 10% .105DX.26LG	28480	9100-2891
A8A1L2	9140-0158	6	1	INDUCTOR RF-CH-MLD 1UH 10% .105DX.26LG	28480	9140-0158
A8A1L3	9100-2250	9	1	INDUCTOR RF-CH-MLD 180NH 10% .105DX.26LG	28480	9100-2250
A8A1L4	9100-2247	4	1	INDUCTOR RF-CH-MLD 100NH 10% .105DX.26LG	28480	9100-2247
A8A1L5	85660-80010	2	1	COIL-40 NH	28480	85660-80010
A8A1MP1				NOT ASSIGNED		
A8A1MP2	1205-0011	0	1	HEAT SINK- TO-5 (FOR Q2)	28480	1205-0011
A8A1MP3	1251-3172	7	7	CONNECTOR-SGL CONT SKT .03-IN-BSC-SZ RND (SOCKETS FOR MICROCIRCUITS)	28480	1251-3172
A8A1MP4	1200-0173	5	1	INSULATOR-TRANSISTOR TO-5 (FOR Q2)	28480	1200-0173
A8A1MP5	1251-2194	1	1	CONNECTOR-SGL CONT SKT .021-IN-BSC-SZ (SOCKETS FOR JUMPER WIRE)	28480	1251-2194
A8A1MP6				NOT ASSIGNED		
A8A1MP7	8151-0014	5	5	WIRE 24AWG 1X24	28480	8151-0014
A8A1Q1	1854-0686	0	1	TRANSISTOR NPN SI TO-72 PD=200MW FT=4GHZ	28480	1854-0686
A8A1Q2	1854-0378	7	1	TRANSISTOR NPN 2N5109 SI TO-39 PD=800MW	3L585	2N5109
A8A1Q3	1854-0475	5	1	TRANSISTOR-DUAL NPN PD=750MW	28480	1854-0475
A8A1Q4	1853-0451	5	2	TRANSISTOR PNP 2N3799 SI TO-18 PD=360MW	01295	2N3799
A8A1Q5	1853-0451	5	2	TRANSISTOR PNP 2N3799 SI TO-18 PD=360MW	01295	2N3799
A8A1Q6	1854-0248	0	1	TRANSISTOR-DUAL NPN 2N4044 TO-77	22229	2N4044
A8A1Q7	1854-0404	0	1	TRANSISTOR NPN SI TO-18 PD=360MW	28480	1854-0404
A8A1Q8	1853-0281	9	1	TRANSISTOR PNP 2N2907A SI TO-18 PD=400MW	04713	2N2907A
A8A1R1	0698-7224	3	1	RESISTOR 316 1% .05W F TC=0 \pm 100	24546	C3-1/8-TO-316R-F
A8A1R2	0698-7188	8	2	RESISTOR 10 1% .05W F TC=0 \pm 100	24546	C3-1/8-TO-10R-F
A8A1R3	0757-0420	3	1	RESISTOR 750 1% .125W F TC=0 \pm 100	24546	C4-1/8-TO-751-F
A8A1R4	0698-3429	2	1	RESISTOR 19.6 1% .125W F TC=0 \pm 100	03888	PME55-1/8-TO-19R6-F
A8A1R5	0698-7203	8	1	RESISTOR 42.2 1% .05W F TC=0 \pm 100	24546	C3-1/8-TO-42R2-F
A8A1R6	0698-7276	5	2	RESISTOR 46.4K 1% .05W F TC=0 \pm 100	24546	C3-1/8-TO-4642-F
A8A1R7	0698-7276	5	2	RESISTOR 46.4K 1% .05W F TC=0 \pm 100	24546	C3-1/8-TO-4642-F
A8A1R8	2100-2030	6	1	RESISTOR-TRMR 20K 10% C TOP-ADJ 1-TRN	73138	82PR20K
A8A1R9	0698-7288	9	2	RESISTOR 147K 1% .05W F TC=0 \pm 100	24546	C3-1/8-TO-1473-F
A8A1R10	0698-7277	6	2	RESISTOR 51.1K 1% .05W F TC=0 \pm 100	24546	C3-1/8-TO-5112-F

See introduction to this section for ordering information
*Indicates factory selected value

Table 6-3. Model 8340A Replaceable Parts

Reference Designation	HP Part Number	C D	Qty	Description	Mfr Code	Mfr Part Number
A8A1R11	0698-7219	6	1	RESISTOR 196 1% .05W F TC=0+100	24546	C3-1/8-T0-196R-F
A8A1R12	0698-7284	5	2	RESISTOR 100K 1% .05W F TC=0+100	24546	C3-1/8-T0-1003-F
A8A1R13	0698-7277	6		RESISTOR 51.1K 1% .05W F TC=0+100	24546	C3-1/8-T0-5112-F
A8A1R14	0698-7288	9		RESISTOR 147K 1% .05W F TC=0+100	24546	C3-1/8-T0-1473-F
A8A1R15	0698-7211	8	1	RESISTOR 90.9 1% .05W F TC=0+100	24546	C3-1/8-T0-9099-F
A8A1R16	0698-7281	2	1	RESISTOR 75K 2% .05W F TC=0+100	24546	C3-1/8-T0-7502-G
A8A1R17	0698-7216	3	1	RESISTOR 147 1% .05W F TC=0+100	24546	C3-1/8-T0-147R-F
A8A1R18	0698-0084	9	1	RESISTOR 2.15K 1% .125W F TC=0+100	24546	C4-1/8-T0-2151-F
A8A1R19	0698-7236	7	1	RESISTOR 1K 1% .05W F TC=0+100	24546	C3-1/8-T0-1001-F
A8A1R20	0698-3154	0	1	RESISTOR 4.22K 1% .125W F TC=0+100	24546	C4-1/8-T0-4221-F
A8A1R21	0698-3161	9	1	RESISTOR 38.3K 1% .125W F TC=0+100	24546	C4-1/8-T0-3832-F
A8A1R22	0698-7284	5		RESISTOR 100K 1% .05W F TC=0+100	24546	C3-1/8-T0-1003-F
A8A1R23	0698-7244	7	1	RESISTOR 2.15K 1% .05W F TC=0+100	24546	C3-1/8-T0-2151-F
A8A1R24	0698-7188	8		RESISTOR 10 1% .05W F TC=0+100	24546	C3-1/8-T0-10R-F
A8A1R25	0698-7205	0	1	RESISTOR 51.1 1% .05W F TC=0+100	24546	C3-1/8-T0-511R-F
A8A1R26	0757-0403	2	1	RESISTOR 121 1% .125W F TC=0+100	24546	C4-1/8-T0-121R-F
A8A1TP1	0360-0535	0	2	TERMINAL TEST POINT PCB	00000	ORDER BY DESCRIPTION
A8A1TP2	0360-0535	0	0	TERMINAL TEST POINT PCB	00000	ORDER BY DESCRIPTION
A8A1U1	1826-0180	0	1	IC TIMER TTL MONO/ASTBL	01295	NE555P
A8A1VR1	1902-3301	5	1	DIODE-ZNR 34.8V 5% DO-35 PD=.4W	28480	1902-3301
A8A2				3.7GHZ OSCILLATOR (NOT SEPARATELY REPLACEABLE; ORDER A8.)		
A8C1	9135-0002	8	5	FILTER-LOW PASS SOLDER-TERMS	33095	51-744-018
A8C2	9135-0002	8		FILTER-LOW PASS SOLDER-TERMS	33095	51-744-018
A8C3	9135-0002	8		FILTER-LOW PASS SOLDER-TERMS	33095	51-744-018
A8C4	9135-0002	8		FILTER-LOW PASS SOLDER-TERMS	33095	51-744-018
A8C5	9135-0002	8		FILTER-LOW PASS SOLDER-TERMS	33095	51-744-018
A8MP1	08340-20082	3	1	BOX 3.7 GHZ OSC.	28480	08340-20082
A8MP2	08340-00020	7	1	LID 3.7 GHZ OSC.	28480	08340-00020
A8MP3	08340-20055	0	1	DONUT RFI SHIELD	28480	08340-20055
A8MP4	2200-0103	2	14	SCREW-MACH 4-40 .25-IN-LG PAN-HD-POZI	00000	ORDER BY DESCRIPTION
A8MP5	0520-0131	2	4	SCREW-MACH 2-56 .438-IN-LG PAN-HD-POZI	00000	ORDER BY DESCRIPTION
A8MP6	2190-0045	8	4	WASHER-LK HLCL NO. 2 .088-IN-ID	28480	2190-0045
A8MP7	2580-0002	4	5	NUT-HEX-DBL-CHAM 8-32-THD .085-IN-THK	00000	ORDER BY DESCRIPTION
A8MP8	2190-0009	4	5	WASHER-LK INTL T NO. 8 .168-IN-ID	28480	2190-0009
A8MP9	1400-0510	8	1	CLAMP-CABLE .15-DIA .62-WD NYL	28480	1400-0510
A8MP10	2950-0078	9	2	NUT-HEX-DBL-CHAM 10-32-THD .067-IN-THK	28480	2950-0078
A8MP11	2190-0124	4	2	WASHER-LK INTL T NO. 10 .195-IN-ID	28480	2190-0124
A8W1	08340-60097	4	1	WIRE ASSEMBLY-A8 TO A20J3	28480	08340-60097

See introduction to this section for ordering information
 *Indicates factory selected value

Table 6-3. Replaceable Parts

Reference Designation	HP Part Number	C D	Qty	Description	Mfr Code	Mfr Part Number
A9	5086-7372	0	1	BAND 0 PULSE MODULATOR	28480	5086-7372
	5086-6372	8	1	EXCHANGE 5086-7372 BAND 0 PULSE MOD.	28480	5086-6372
A10	0955-0125	5	1	DIRECTIONAL COUPLER	28480	0955-0125
A11	08340-60130	6	1	BAND 1-4 DETECTOR	28480	08340-60130
A12	5086-7434	5	1	BAND 0 SPLITTER/DETECTOR (DOES NOT INCLUDE A12W1)	28480	5086-7434
	08340-60240	9	1	BAND 0 SPLITTER/DETECTOR REPLACEMENT KIT (REQUIRED FOR INSTRUMENTS WITH SERIAL PREFIX 2430A AND BELOW. INCLUDES 5086-7434, REQ'D HARDWARE, AND SERVICE NOTE)	28480	08340-60240
A12W1	08340-60122	6	1	WIRE ASSEMBLY- A12 TO A62J34	28480	08340-60122
A13	5086-7508	1		BAND 1-4 SWITCHED YIG TUNED MULTIPLIER (FOR SYTM REPLACEMENT, ORDER ONE OF THE FOLLOWING SYTM REPLACEMENT KITS. THESE KITS PROVIDE THE A13 MICROCIRCUIT, THE A13A1 PC BOARD, AND REQUIRED HARDWARE.)	28480	5086-7508
	5086-6508			EXCHANGE 5086-7508 SYTM (FOR SYTM REPLACEMENT, ORDER ONE OF THE FOLLOWING SYTM REPLACEMENT KITS. THESE KITS PROVIDE THE A13 MICROCIRCUIT, THE A13A1 PC BOARD, AND REQUIRED HARDWARE.)	28480	5086-6508
				NOTE: When ordering a replacement SYTM or SYTM Bias assy (not separately replaceable) order one of the following replacement kits. DO NOT ORDER THE INDIVIDUAL ASSY'S PART NUMBER. If ordering a replacement kit for an instrument with a serial prefix of 2506A or below, two potentiometers and one resistor must be changed on the A28 SYTM Driver Assembly. Refer to Service note 8340A-14 for details.		
	08340-60241	0		SYTM REPLACEMENT KIT, NEW	28480	08340-60241
	08340-60242	1		SYTM REPLACEMENT KIT, EXCHANGE	28480	08340-60242
A13A1	5061-1090	1		SYTM BIAS BOARD ASSEMBLY (NOT SEPARATELY REPLACEABLE, ORDER ONE OF THE SYTM REPLACEMENT KITS SHOWN ABOVE.)	28480	5061-1090
A13A1C1	0160-3456	6	1	CAPACITOR-FXD 1000PF +-10% 1KVDC CER	28480	0160-3456
A13A1CR1	1901-0033	2	1	DIODE-GEN PRP 180V 200MA DO-7	28480	1901-0033
A13A1J1	1200-0482	9	1	SOCKET-IC 16-CONT DIP-SLDR	28480	1200-0482
A13A1J2	1251-3172	7	4	CONNECTOR-SGL CONT SKT .03-IN-BSC-SZ RND	28480	1251-3172
A13A1J3	1251-3172	7		CONNECTOR-SGL CONT SKT .03-IN-BSC-SZ RND	28480	1251-3172
A13A1J4	1251-3172	7		CONNECTOR-SGL CONT SKT .03-IN-BSC-SZ RND	28480	1251-3172
A13A1J5	1251-3172	7		CONNECTOR-SGL CONT SKT .03-IN-BSC-SZ RND	28480	1251-3172
A13A1MP1	0380-1272	6	2	SPACER-RVT-ON .125-IN-LG .098-IN-ID	00000	ORDER BY DESCRIPTION
A13A1R1	0757-0401	0	1	RESISTOR 100 1% .125W F TC=0+-100	24546	C4-1/B-T0-101-F
A13A1TP1	0360-0535	0	1	TERMINAL TEST POINT PCB	00000	ORDER BY DESCRIPTION
A13A1VR1	1902-0175	5	1	DIODE-ZNR 100V 5% PD=1W IR=5UA	28480	1902-0175
A13MP1	5021-5361	7	1	SYTM SPACER	28480	5021-5361
A13MP2	5086-3460	9	1	CENTER BODY ASSEMBLY	28480	5086-3460
A13MP3	0520-0129	8	2	SCREW-MACH 2-56 .312-IN-LG PAN-HD-POZI	00000	ORDER BY DESCRIPTION
A13MP4	2190-0890	1	2	WASHER-LK HLCL NO. 2 .088-IN-ID	28480	2190-0890

See introduction to this section for ordering information.

*Indicates factory stock item.

Table 6-3. Replaceable Parts

Reference Designation	HP Part Number	C D	Qty	Description	Mfr Code	Mfr Part Number
A14	5086-7407	2	1	BAND 1-4 POWER AMPLIFIER (5086-7407 INCLUDES A14A1 PC BOARD AND A14 MICROCIRCUIT.) NOTE Order power amp replacement kit, HP part Number 08340-60204, CD5.	28480	5086-7407
	5086-6407	0	1	EXCHANGE 5086-7407 BAND 1-4 PWR AMP NOTE Order exchange 5086-7407 power amp replacement kit, HP Part Number 08340-60196 CD4	28480	5086-6407
A14A1	5061-5326	8	1	BAND 1-4 POWER AMP BIAS BOARD	28480	5061-5326
A14A1C1	0160-0174	9	2	CAPACITOR-FXD .47UF +80-20% 25VDC CER	28480	0160-0174
A14A1C2	0180-1704	5	4	CAPACITOR-FXD 47UF±10% 6VDC TA	56289	150D476X9006B2
A14A1C3	0180-1704	5	5	CAPACITOR-FXD 47UF±10% 6VDC TA	56289	150D476X9006B2
A14A1C4	0180-0228	6	1	CAPACITOR-FXD 22UF±10% 15VDC TA	56289	150D226X9015B2
A14A1C5	0180-0291	3	1	CAPACITOR-FXD 1UF±10% 35VDC TA	56289	150D105X9035A2
A14A1C6	0180-1704	5	5	CAPACITOR-FXD 47UF±10% 6VDC TA	56289	150D476X9006B2
A14A1C7	0180-1704	5	5	CAPACITOR-FXD 47UF±10% 6VDC TA	56289	150D476X9006B2
A14A1C8	0160-0174	9	9	CAPACITOR-FXD .47UF +80-20% 25VDC CER	28480	0160-0174
A14A1C9	0160-4084	8	1	CAPACITOR-FXD .1UF +20% 50VDC CER	28480	0160-4084
A14A1C10	0160-3879	7	1	CAPACITOR-FXD .01UF ±20% 100VDC CER	28480	0160-3879
A14A1E1-E12	1251-3172	7	12	CONNECTOR-SGL CONT SKT .03-IN-BSC-SZ RND	28480	1251-3172
A14A1J1	1200-0507	9	1	SOCKET-IC 16-CONT DIP-SLDR	28480	1200-0507
A14A1MP1	0380-0322	5	8	SPACER-RVT-ON .062-IN-LG .152-IN-ID	00000*	ORDER BY DESCRIPTION
A14A1MP2	1200-0173	5	1	INSULATOR-XSTR DAP-GL	28480	1200-0173
A14A1MP3	0340-0614	4	1	INSULATOR-XSTR POLYI HD-ANDZ	28480	0340-0614
A14A1MP4	0590-0106	8	1	NUT-HEX-PLSTC LKG 2-56-THD .143-IN-THK	00000	ORDER BY DESCRIPTION
A14A1MP5	5001-1600	7	1	HEAT SINK/BRACKET	28480	5001-1600
A14A1MP6	5021-0950	0	1	BOARD INSULATOR	28480	5021-0950
A14A1MP7	5021-2519	1	1	INSULATOR	28480	5021-2519
A14A1Q1	1854-0477	7	1	TRANSISTOR NPN 2N2222A SI TO-18 PD=500MW	04713	2N2222A
A14A1Q2	1853-0213	7	1	TRANSISTOR PNP 2N4236 SI TO-5 PD=1W	04713	2N4236
A14A1Q3	1853-0281	9	1	TRANSISTOR NPN 2N2194 SI TO-5 PD=800MW	01698	2N2194
A14A1R1	0698-3443	0	2	RESISTOR 287 1% .125W F TC=0+100	24546	C4-1/8-T0-287R-F
A14A1R2	0757-0420	3	1	RESISTOR 750 1% .125W F TC=0+100	24546	C4-1/8-T0-751-F
A14A1R3	0698-3441	8	3	RESISTOR 215 1% .125W F TC=0+100	24546	C4-1/8-T0-215R-F
A14A1R4	0698-3441	8	8	RESISTOR 215 1% .125W F TC=0+100	24546	C4-1/8-T0-215R-F
A14A1R5	0757-0280	3	1	RESISTOR 1K 1% .125W F TC=0+100	24546	C4-1/8-T0-1001-F
A14A1R6	0757-0198	2	1	RESISTOR 100 1% .5W F TC=0+100	28480	0757-0198
A14A1R7	0757-0417	8	2	RESISTOR 562 1% .125W F TC=0+100	24546	C4-1/8-T0-562R-F
A14A1R8	0757-0400	9	2	RESISTOR 90.9 1% .125W F TC=0+100	24546	C4-1/8-T0-90R9-F
A14A1R9	0757-0400	9	9	RESISTOR 90.9 1% .125W F TC=0+100	24546	C4-1/8-T0-90R9-F
A14A1R10	0698-3441	8	8	RESISTOR 215 1% .125W F TC=0+100	24546	C4-1/8-T0-215R-F
A14A1R11	2100-1738	9	6	RESISTOR-TRMR 10K 10% C TOP-ADJ 1-TRN	73138	82PR10K
A14A1R12	2100-1738	9	9	NOT ASSIGNED	73138	82PR10K
A14A1R13	2100-1738	9	9	RESISTOR-TRMR 10K 10% C TOP-ADJ 1-TRN	73138	82PR10K
A14A1R14	2100-1738	9	9	RESISTOR-TRMR 10K 10% C TOP-ADJ 1-TRN	73138	82PR10K
A14A1R15	2100-1738	9	9	RESISTOR-TRMR 10K 10% C TOP-ADJ 1-TRN	73138	82PR10K
A14A1R16	2100-1738	9	9	RESISTOR-TRMR 10K 10% C TOP-ADJ 1-TRN	73138	82PR10K
A14A1R17	2100-1738	9	9	NOT ASSIGNED	73138	82PR10K
A14A1R18	2100-1738	9	9	RESISTOR-TRMR 10K 10% C TOP-ADJ 1-TRN	73138	82PR10K
A14A1R19	0757-0442	9	6	RESISTOR 10K 1% .125W F TC=0+100	24546	C4-1/8-T0-1002-F
A14A1R20	0757-0442	9	9	NOT ASSIGNED	24546	C4-1/8-T0-1002-F
A14A1R21	0757-0442	9	9	RESISTOR 10K 1% .125W F TC=0+100	24546	C4-1/8-T0-1002-F
A14A1R22	0757-0442	9	9	RESISTOR 10K 1% .125W F TC=0+100	24546	C4-1/8-T0-1002-F
A14A1R23	0757-0442	9	9	RESISTOR 10K 1% .125W F TC=0+100	24546	C4-1/8-T0-1002-F
A14A1R24	0757-0442	9	9	RESISTOR 10K 1% .125W F TC=0+100	24546	C4-1/8-T0-1002-F
A14A1R25	0757-0442	9	9	NOT ASSIGNED	24546	C4-1/8-T0-1002-F
A14A1R26	0757-0442	9	9	RESISTOR 10K 1% .125W F TC=0+100	24546	C4-1/8-T0-1002-F
A14A1R27	0757-0417	8	8	RESISTOR 562 1% .125W F TC=0+100	24546	C4-1/8-T0-562R-F
A14A1R28	0757-0403	2	1	RESISTOR 121 1% .125W F TC=0+100	24546	C4-1/8-T0-121R-F
A14A1R29	0698-0084	9	2	NOT ASSIGNED	24546	C4-1/8-T0-121R-F
A14A1R30	0698-0084	9	2	RESISTOR 2.15K 1% .125W F TC=0+100	24546	C4-1/8-T0-2151-F
A14A1R31	0698-0084	9	9	RESISTOR 2.15K 1% .125W F TC=0+100	24546	C4-1/8-T0-2151-F
A14A1R32	0757-0465	6	1	RESISTOR 100K 1% .125W F TC=0+100	24546	C4-1/8-T0-1003-F
A14A1R33	0757-0401	0	1	RESISTOR 100 1% .125W F TC=0+100	24546	C4-1/8-T0-101-F

See introduction to this section for ordering information
*Indicates factory selected value

Table 6-3. Replaceable Parts

Reference Designation	HP Part Number	C D	Qty	Description	Mfr Code	Mfr Part Number
A14A1R34	0757-0438	3	1	RESISTOR 5.11K 1% .125W F TC=0+100	24546	C4-1/8-TO-5111-F
A14A1R35	0757-0279	0	1	RESISTOR 3.16K 1% .125W F TC=0+100	24546	C4-1/8-TO-3161-F
A14A1U1	1826-0527	9	1	IC V RGLTR-ADJ-NEG 1.2/37V TO-220 PKG	28480	1826-0527
A14A1VR1	1902-0551	1	1	DIODE-ZNR 6.2V 5% PD=1W IR=10UA	28480	1902-0551
A14A1VR2	1902-0029	8	1	DIODE-ZNR 12V 5% PD=1W IR=5UA	28480	1902-0029

See introduction to this section for ordering information
 *Indicates factory selected value

Table 6-3. Replaceable Parts

Reference Designation	HP Part Number	C D	Qty	Description	Mfr Code	Mfr Part Number
A15	9135-0191	6	1	BAND 0 LOW PASS FILTER	28480	9135-0191
A16	5086-7304 5086-6304	0 8	1 1	BAND 1-4 MODULATOR/SPLITTER EXCHANGE 5086-7304 BAND 1-4 MOD/SPL	28480 28480	5086-7304 5086-6304
A16A1	5061-5323	5	1	BAND 1-4 MODULATOR/SPLITTER BIAS BOARD	28480	5061-5323
A16A1C1	0160-0174	9	1	CAPACITOR-FXD .47UF +80-20% 25VDC CER	28480	0160-0174
A16A1C2	0180-1704	5	2	CAPACITOR-FXD 47UF+-10% 6VDC TA	56289	150D476X9006B2
A16A1C3	0180-1704	5		CAPACITOR-FXD 47UF+-10% 6VDC TA	56289	150D476X9006B2
A16A1J1	1200-0482	9	1	SOCKET-IC 16-CONT DIP-SLDR	28480	1200-0482
A16A1J2	1250-1849	9	1	CONNECTOR-RF FEEDTHRU CAPACITOR; 50 OHMS	28480	1250-1849
A16A1MP1	2200-0107	6	4	SCREW-MACH 4-40 .375-IN-LG PAN-HD-POZI	00000	ORDER BY DESCRIPTION
A16A1MP2	0380-0321	4	5	SPACER-RVT-ON .125-IN-LG .152-IN-ID NOT ASSIGNED	00000	ORDER BY DESCRIPTION
A16A1MP3				NOT ASSIGNED		
A16A1MP4				CONNECTOR-SGL CONT SKT .03-IN-BSC-SZ RND	28480	1251-3172
A16A1MP5	1251-3172	7	1			
A16A1Q1	1853-0281	9	1	TRANSISTOR PNP 2N2907 A SI TO-18 PD=400MW	04713	2N2907A
A16A1R1	0698-3441	8	2	RESISTOR 215 1% .125W F TC=0+-100	24546	C4-1/B-T0-215R-F
A16A1R2	0698-3441	8		RESISTOR 215 1% .125W F TC=0+-100	24546	C4-1/B-T0-215R-F
A16A1R3	0698-3443	0	2	RESISTOR 287 1% .125W F TC=0+-100	24546	C4-1/B-T0-287R-F
A16A1R4	2100-1738	9	2	RESISTOR-TRMR 10K 10% C TOP-ADJ 1-TRN	73138	B2PR10K
A16A1R5	0757-0442	9	2	RESISTOR 10K 1% .125W F TC=0+-100	24546	C4-1/B-T0-1002-F
A16A1R6	2100-1738	9		RESISTOR-TRMR 10K 10% C TOP-ADJ 1-TRN	73138	B2PR10K
A16A1R7	0757-0442	9		RESISTOR 10K 1% .125W F TC=0+-100	24546	C4-1/B-T0-1002-F
A16A1R8	0698-3443	0		RESISTOR 287 1% .125W F TC=0+-100	24546	C4-1/B-T0-287R-F
A16A1R9	0757-0280	3	1	RESISTOR 1K 1% .125W F TC=0+-100	24546	C4-1/B-T0-1001-F
A16A1VR1	1902-0551	1	1	DIODE-ZNR 62V 5% PD=1W IR=10UA	28480	1902-0551
A17	5086-7374 5086-6374	2 0	1	BAND 0 MIXER EXCHANGE 5086-7374 BAND 0 MIXER	28480 28480	5086-7374 5086-6374
A18	5086-7217	2	1	BAND 0 POWER AMPLIFIER (5086-7217 INCLUDES A18 MICROCIRCUIT AND A18A1 PC BOARD BUT DOES NOT INCLUDE A18A2 BAND 0 SPLITTER.)	28480	5086-7217
	5086-6217	0		EXCHANGE 5086-7217 BAND 0 PWR AMPLIFIER	28480	5086-6217
A18A1	5060-0325	5	1	BAND 0 POWER AMP BIAS BOARD	28480	5060-0325
A18A1R1	0698-3445	2	1	RESISTOR 348 1% .125W F TC=0+-100	24546	C4-1/B-T0-348R-F
A18A1R2	0698-3132	4	1	RESISTOR 261 1% .125W F TC=0+-100	24546	C4-1/B-T0-2610-F
A18A1R3	0698-3437	2	1	RESISTOR 133 1% .125W F TC=0+-100	24546	C4-1/B-T0-133R-F
A18A1R4	0757-0419	0	1	RESISTOR 681 1% .125W F TC=0+-100	24546	C4-1/B-T0-681R-F
A18A1R5	0757-0417	8	1	RESISTOR 562 1% .125W F TC=0+-100	24546	C4-1/B-T0-562R-F
A18A1R6	0698-3447	4	1	RESISTOR 422 1% .125W F TC=0+-100	24546	C4-1/B-T0-422R-F
A18A1R7	0757-1090	5		RESISTOR 261 1% .5W F TC=0+-100	28480	0757-1090
A18A1R8*	0698-3102	8	1	RESISTOR 237 1% .5W F TC=0+-100	28480	0698-3102
A18A1R8*	0698-3334	8	1	RESISTOR 178 1% .5W F TC=0+-100	28480	0698-3334
A18A1R8*	0698-3401	0	1	RESISTOR 215 1% .5W F TC=0+-100	28480	0698-3401
A18A1R8*	0757-1060	9	1	RESISTOR 196 1% .5W F TC=0+-100	28480	0757-1060
A18A1R8*	0757-1090	5	2	RESISTOR 261 1% .5W F TC=0+-100	28480	0757-1090
A18A1R8*	0757-1092	7	1	RESISTOR 287 1% .5W F TC=0+-100	28480	0757-1092
A18A1R9	0757-0794	4	1	RESISTOR 68.1 1% .5W F TC=0+-100 R10 IS FACTORY SELECTED FROM THE FOLLOWING VALUES:	28480	0757-0794
A18A1R10						
	0757-0795	5		RESISTOR 75 1% .5W F TC=0+-100	19701	MF-1/2-T0-75R0-F
	0757-0796	6		RESISTOR 82.5 1% .5W F TC=0+-100	28480	0757-0796
	0757-0797	7		RESISTOR 90.9 1% .5W F TC=0+-100	28480	0757-0797
	0757-1000	7		RESISTOR 51.1 1% .5W F TC=0+-100	28480	0757-1000
	0757-1001	8		RESISTOR 56.2 1% .5W F TC=0+-100	28480	0757-1001
	0757-1002	9		RESISTOR 61.9 1% .5W F TC=0+-100	28480	0757-1002
A18A1W1	08340-60099	6	1	WIRE ASSEMBLY A18A1 TO A20J4 (NOT INCLUDED WITH A18 OR A18A1)	28480	08340-60099

See Introduction to this section for ordering information.

*Indicates factory selected value.

Table 6-3. Replaceable Parts

Reference Designation	HP Part Number	C D	Qty	Description	Mfr Code	Mfr Part Number
A18MP1	5020-8550	0	1	DIELECTRIC SPACER	26480	5020-8550

See introduction to this section for ordering information.

*Indicate factory selected value.

Table 6-3. Model 8340A Replaceable Parts

Reference Designation	HP Part Number	C D	Qty	Description	Mfr Code	Mfr Part Number
A19	08340-60003	2	1	CAPACITOR ASSEMBLY	28480	08340-60003
A19C1	0160-2055	9	2	CAPACITOR-FXD .01UF +80-20% 100VDC CER	28480	0160-2055
A19C2	0160-2055	9		CAPACITOR-FXD .01UF +80-20% 100VDC CER	28480	0160-2055
A19C3	0160-3638	6	2	CAPACITOR-FXD .22UF +80-20% 200VDC CER	28480	0160-3638
A19C4	0160-5647	1	1		28480	0160-5647
A19C5	0180-2603	5	2	CAPACITOR-FXD 7200UF+75-10% 50VDC AL	28480	0180-2603
A19C6	0180-2603	5		CAPACITOR-FXD 7200UF+75-10% 50VDC AL	28480	0180-2603
A19C7	0180-2671	7	3	CAPACITOR-FXD .012F+75-10% 30VDC AL	00853	500123U030AC2*
A19C8	0180-2671	7		CAPACITOR-FXD .012F+75-10% 30VDC AL	00853	500123U030AC*
A19C9	0180-2671	7		CAPACITOR-FXD .012F+75-10% 30VDC AL	00853	500123U030AC*
A19C10	0160-3638	6		CAPACITOR-FXD .22UF +80-20% 200VDC CER	28480	0160-3638
A19CR1	1901-0662	3	4	DIODE-PWR RECT 100V 6A	04713	MR751
A19CR2	1901-0662	3		DIODE-PWR RECT 100V 6A	04713	MR751
A19CR3	1901-0662	3		DIODE-PWR RECT 100V 6A	04713	MR751
A19CR4	1901-0662	3		DIODE-PWR RECT 100V 6A	04713	MR751
A19CR5	1901-0935	3	4	DIODE-PWR RECT 45V 8A	28480	1901-0935
A19CR6	1901-0935	3		DIODE-PWR RECT 45V 8A	28480	1901-0935
A19CR7	1901-0935	3		DIODE-PWR RECT 45V 8A	28480	1901-0935
A19CR8	1901-0935	3		DIODE-PWR RECT 45V 8A	28480	1901-0935
A19DS1	1990-0486	6	1	LFD-LAMP LUM-INT=1MCD IF=20MA-MAX BVR=5V	28480	5082 4684
A19MP1	2190-0011	8	10	WASHER-LK INTL T NO. 10 .195-IN-ID	28480	2190-0011
A19MP2	2680-0129	8	10	SCREW-MACH 10-32 .312-IN-LG PAN-HD-POZI	00000	ORDER BY DESCRIPTION
A19MP3	2360-0113	2	3	SCREW-MACH 6-32 .25-IN-LG PAN-HD-POZI	00000	ORDER BY DESCRIPTION
A19MP4	08340-00019	4	1	CAP SHIELD	28480	08340-00019
A19R1	0764-0016	8	2	RESISTOR 1K 5% 2W MO TC=0+200	28480	0764-0016
A19R2	0698-3407	6	1	RESISTOR 1.96K 1% .5W F TC=0+100	28480	0698-3407
A19R3	0757-1078	9	1	RESISTOR 1.47K 1% .5W F TC=0+100	28480	0757-1078
A19R4	0764-0016	8		RESISTOR 1K 5% 2W MO TC=0+200	28480	0764-0016
A19TP1	0360-0535	0	1	TERMINAL TEST POINT PCB	00000	ORDER BY DESCRIPTION

See introduction to this section for ordering information
 *Indicates factory selected value

Table 6-3. Replaceable Parts

Reference Designation	HP Part Number	C D	Qty	Description	Mfr Code	Mfr Part Number
A20	08340-60203	4	1	RF SECTION FILTER	28480	08340-60203
A20C1	0180-2614	8	2	CAPACITOR-FXD 100UF+10% 30VDC TA	56289	150D107X9030S2
A20C2	0160-4835	7	2	CAPACITOR-FXD .1UF +10% 50VDC CER	28480	0160-4835
A20C3	0180-2614	8		CAPACITOR-FXD 100UF+10% 30VDC TA	56289	150D107X9030S2
A20C4	0180-0094	4	2	CAPACITOR-FXD 100UF+75-10% 25VDC AL	56289	30D107G025DD2
A20C5	0160-4835	7		CAPACITOR-FXD .1UF +10% 50VDC CER	28480	0160-4835
A20C6	0180-0094	4		CAPACITOR-FXD 100UF+75-10% 25VDC AL	56289	30D107G025DD2
A20C7	0180-0116	1	1	CAPACITOR-FXD 6.8UF+10% 35VDC TA	56289	150D685X9035B2
A20J1	1200-0482	9	2	SOCKET-IC 16-CONT DIP-SLDR	28480	1200-0482
A20J2	1200-0482	9		SOCKET-IC 16-CONT DIP-SLDR	28480	1200-0482
A20J3	1251-6794	5	1	CONNECTOR HEADER 5 M IR	28480	1251-6794
A20J4	1251-6795	6	1	CONNECTOR HEADER 3 M IR	28480	1251-6795
A20L1	08340-80001	2	4	COIL-TOROID	28480	08340-80001
A20L2	08340-80001	2		COIL-TOROID	28480	08340-80001
A20L3	08340-80001	2		COIL-TOROID	28480	08340-80001
A20L4	08340-80001	2		COIL-TOROID	28480	08340-80001
A20L5	9100-0539	3	1	INDUCTOR (MISC ITEM)	28480	9100-0539
A20MP1	0380-0773	0	4	SPACER-RVT-ON .5-IN-LG .152-IN-ID	00000	ORDER BY DESCRIPTION
A20Q1	1853-0281	9	1	TRANSISTOR PNP 2N2907A SI TO-18 PD=400MW	04713	2N2907A
A20Q2	1854-0361	8	1	TRANSISTOR NPN 2N4239 SI TO-5 PD=6W	04713	2N4239
A20R1	0757-0442	9	1	RESISTOR 10K 1% .125W F TC=0+100	24546	C4-1/8-T0-1002-F
A20R2	0757-1094	9	1	RESISTOR 1.47K 1% .125W F TC=0+100	24546	C4-1/8-T0-1471-F
A20R3	0757-0290	5	1	RESISTOR 6.19K 1% .125W F TC=0+100	19701	MF4C1/8-T0-6191-F
A20R4	0757-1090	5	1	RESISTOR 261 1% .5W F TC=0+100	28480	0757-1090
A20R5	0757-0280	3	1	RESISTOR 1K 1% .125W F TC=0+100	24546	C4-1/8-T0-1001-F

See introduction to this section for ordering information
 *Indicates factory selected value

Table 6-3. Replaceable Parts

Reference Designation	HP Part Number	C D	Qty	Description	Mfr Code	Mfr Part Number
A21	08340-60160	2	1	PULSE MODULATOR DRIVER	28480	08340-60160
A21C1*	0160-4492	2	1	CAPACITOR-FXD 18PF +5% 200VDC CER 0+30	28480	0160-4492
A21C2	0160-4084	8	4	CAPACITOR-FXD .1UF +20% 50VDC CER	28480	0160-4084
A21C3	0160-0127	2	2	CAPACITOR-FXD 1UF +20% 25VDC CER	28480	0160-0127
A21C4	0160-0127	2		CAPACITOR-FXD 1UF +20% 25VDC CER	28480	0160-0127
A21C5	0160-0574	3	1	CAPACITOR-FXD .022UF +20% 100VDC CER	28480	0160-0574
A21C6	0160-4084	8		CAPACITOR-FXD .1UF +20% 50VDC CER	28480	0160-4084
A21C7	0160-4822	2	1	CAPACITOR-FXD 1000PF +5% 100VDC CER	28480	0160-4822
A21C8	0160-4823	3	1	CAPACITOR-FXD 820PF +5% 100VDC CER	28480	0160-4823
A21C9	0160-4808	4	1	CAPACITOR-FXD 470PF +5% 100VDC CER	02798	0160-4808
A21C10	0160-0573	2	1	CAPACITOR-FXD 4700PF +20% 100VDC CER	28480	0160-0573
A21C11	0160-4809	5	1	CAPACITOR-FXD 390PF +5% 100VDC CER	28480	0160-4809
A21C12	0160-4386	3	1	CAPACITOR-FXD 33PF +5% 200VDC CER 0+30	28480	0160-4386
A21C13	0160-4387	4	1	CAPACITOR-FXD 47PF +5% 200VDC CER 0+30	28480	0160-4387
A21C14	0160-4084	8		CAPACITOR-FXD .1UF +20% 50VDC CER	28480	0160-4084
A21C15	0160-4084	8		CAPACITOR-FXD .1UF +20% 50VDC CER	28480	0160-4084
A21C16	0180-0229	7	1	CAPACITOR-FXD 33UF+10% 10VDC TA	56289	150D336X9010B2
A21C17	0180-0116	1	1	CAPACITOR-FXD 6.8UF+10% 35VDC TA	56289	150D685X9035B2
A21CR1	1901-0050	3	9	DIODE-SWITCHING 80V 200MA 2NS DO-35	28480	1901-0050
A21CR2	1901-0050	3		DIODE-SWITCHING 80V 200MA 2NS DO-35	28480	1901-0050
A21CR3	1901-0050	3		DIODE-SWITCHING 80V 200MA 2NS DO-35	28480	1901-0050
A21CR4	1901-0050	3		DIODE-SWITCHING 80V 200MA 2NS DO-35	28480	1901-0050
A21CR5	1901-0050	3		DIODE-SWITCHING 80V 200MA 2NS DO-35	28480	1901-0050
A21CR6	1901-0050	3		DIODE-SWITCHING 80V 200MA 2NS DO-35	28480	1901-0050
A21CR7	1901-0539	3	1	DIODE-SM SIG SCHOTTKY	28480	1901-0539
A21CR8	1901-0050	3		DIODE-SWITCHING 80V 200MA 2NS DO-35	28480	1901-0050
A21CR9	1901-0050	3		DIODE-SWITCHING 80V 200MA 2NS DO-35	28480	1901-0050
A21CR10	1901-0050	3		DIODE-SWITCHING 80V 200MA 2NS DO-35	28480	1901-0050
A21CR11	1901-0050	3		DIODE-SWITCHING 80V 200MA 2NS DO-35	28480	1901-0050
A21CR12	1901-0050	3		DIODE-SWITCHING 80V 200MA 2NS DO-35	28480	1901-0050
A21L1	9100-3562	8	2	COIL-4.7 UH 5%	28480	9100-3562
A21L2	9100-3562	8		COIL-4.7 UH 5%	28480	9100-3562
A21L3	9140-0138	2	1	INDUCTOR RF-CH-MLD 180UH 5% .166DX.385LG	28480	9140-0138
A21L4	9140-0129	1	2	INDUCTOR RF-CH-MLD 220UH 5% .166DX.385LG	28480	9140-0129
A21L5	9100-3912	2	1	INDUCTOR RF-CH-MLD 15UH 5% .166DX.385LG	28480	9100-3912
A21L6	9140-0129	1		INDUCTOR RF-CH-MLD 220UH 5% .166DX.385LG	28480	9140-0129
A21L7	9140-0237	2	1	INDUCTOR RF-CH-MLD 200UH 5% .166DX.385LG	28480	9140-0237
A21MP1	4040-0750	7	1	EXTR-PC BD RED POLYC .062-BD-THKNS	28480	4040-0750
A21MP2	4040-0749	4	1	EXTR-PC BD BRN POLYC .062-BD-THKNS	28480	4040-0749
A21MP3, 4	1480-0073	6	2	PIN-ROLL .062-IN-DIA .25-IN-LG BE-CU	28480	1480-0073
A21Q1	1854-0809	9	7	TRANSISTOR NPN 2N2369A SI TO-18 PD=360MW	28480	1854-0809
A21Q2	1853-0018	0	2	TRANSISTOR PNP SI TO-72 PD=200MW FT=1GHZ	28480	1853-0018
A21Q3	1853-0018	0		TRANSISTOR PNP SI TO-72 PD=200MW FT=1GHZ	28480	1853-0018
A21Q4	1854-0809	9		TRANSISTOR NPN 2N2369A SI TO-18 PD=360MW	28480	1854-0809
A21Q5	1854-0809	9		TRANSISTOR NPN 2N2369A SI TO-18 PD=360MW	28480	1854-0809
A21Q6	1854-0809	9		TRANSISTOR NPN 2N2369A SI TO-18 PD=360MW	28480	1854-0809
A21Q7	1854-0809	9		TRANSISTOR NPN 2N2369A SI TO-18 PD=360MW	28480	1854-0809
A21Q8	1853-0405	9	1	TRANSISTOR PNP SI PD=300MW FT=850MHZ	04713	2N4209
A21Q9	1854-0809	9		TRANSISTOR NPN 2N2369A SI TO-18 PD=360MW	28480	1854-0809
A21Q10	1854-0809	9		TRANSISTOR NPN 2N2369A SI TO-18 PD=360MW	28480	1854-0809
A21Q11	1855-0251	7	2	TRANSISTOR MOSFET N-CHAN E-MODE TO-39 SI	28480	1855-0251
A21Q12	1855-0251	7		TRANSISTOR MOSFET N-CHAN E-MODE TO-39 SI	28480	1855-0251
A21R1	0757-0279	0	1	RESISTOR 3.16K 1% .125W F TC=0+100	24546	C4-1/8-T0-3161-F
A21R2	0757-0416	7	3	RESISTOR 511 1% .125W F TC=0+100	24546	C4-1/8-T0-511R-F
A21R3	0757-0280	3	4	RESISTOR 1K 1% .125W F TC=0+100	24546	C4-1/8-T0-1001-F
A21R4	0757-0280	3		RESISTOR 1K 1% .125W F TC=0+100	24546	C4-1/8-T0-1001-F
A21R5	0757-0280	3		RESISTOR 1K 1% .125W F TC=0+100	24546	C4-1/8-T0-1001-F
A21R6	0698-3440	7	2	RESISTOR 196 1% .125W F TC=0+100	24546	C4-1/8-T0-196R-F
A21R7	0757-0416	7		RESISTOR 511 1% .125W F TC=0+100	24546	C4-1/8-T0-511R-F
A21R8	0698-3444	1	2	RESISTOR 316 1% .125W F TC=0+100	24546	C4-1/8-T0-316R-F
A21R9	0698-3440	7		RESISTOR 196 1% .125W F TC=0+100	24546	C4-1/8-T0-196R-F
A21R10	0698-0084	9	1	RESISTOR 2.15K 1% .125W F TC=0+100	24546	C4-1/8-T0-2151-F
A21R11	0757-0394	0	2	RESISTOR 51.1 1% .125W F TC=0+100	24546	C4-1/8-T0-51R1-F
A21R12	0757-0346	2	1	RESISTOR 10 1% .125W F TC=0+100	24546	C4-1/8-T0-10R0-F
A21R13	0757-0465	6	2	RESISTOR 100K 1% .125W F TC=0+100	24546	C4-1/8-T0-1003-F
A21R14	0757-0465	6		RESISTOR 100K 1% .125W F TC=0+100	24546	C4-1/8-T0-1003-F
A21R15	0757-0317	7	1	RESISTOR 1.33K 1% .125W F TC=0+100	24546	C4-1/8-T0-1331-F
A21R16	0698-3152	8	1	RESISTOR 3.48K 1% .125W F TC=0+100	24546	C4-1/8-T0-3481-F
A21R17	0757-0458	7	1	RESISTOR 51.1K 1% .125W F TC=0+100	24546	C4-1/8-T0-5112-F
A21R18	0698-3132	4	1	RESISTOR 261 1% .125W F TC=0+100	24546	C4-1/8-T0-2610-F
A21R19	0757-0419	0	1	RESISTOR 681 1% .125W F TC=0+100	24546	C4-1/8-T0-681R-F
A21R20	0698-0083	8	2	RESISTOR 1.96K 1% .125W F TC=0+100	24546	C4-1/8-T0-1961-F

See introduction to this section for ordering information
 *Indicates factory selected value

Table 6-3. Replaceable Parts

Reference Designation	HP Part Number	C D	Qty	Description	Mfr Code	Mfr Part Number
A21R21	2100-3353	8	1	RESISTOR-TRMR 20K 10% C SIDE-ADJ 1-TRN	28480	2100-3353
A21R22	0757-0438	3	1	RESISTOR 5.11K 1% .125W F TC=0+100	24546	C4-1/8-T0-5111-F
A21R23	2100-3273	1	1	RESISTOR-TRMR 2K 10% C SIDE-ADJ 1-TRN	28480	2100-3273
A21R24	0698-3441	8	1	RESISTOR 215 1% .125W F TC=0+100	24546	C4-1/8-T0-215R-F
A21R25	0757-0416	7	1	RESISTOR 511 1% .125W F TC=0+100	24546	C4-1/8-T0-511R-F
A21R26	0757-0394	0		RESISTOR 51.1 1% .125W F TC=0+100	24546	C4-1/8-T0-51R1-F
A21R27	0757-0402	1	2	RESISTOR 110 1% .125W F TC=0+100	24546	C4-1/8-T0-111-F
A21R28	0757-0402	1		RESISTOR 110 1% .125W F TC=0+100	24546	C4-1/8-T0-111-F
A21R29	0757-0418	9	2	RESISTOR 619 1% .125W F TC=0+100	24546	C4-1/8-T0-619R-F
A21R30	0698-3444	1	1	RESISTOR 316 1% .125W F TC=0+100	24546	C4-1/8-T0-316R-F
A21R31	0757-0422	5	2	RESISTOR 909 1% .125W F TC=0+100	24546	C4-1/8-T0-909R-F
A21R32	0757-0422	5		RESISTOR 909 1% .125W F TC=0+100	24546	C4-1/8-T0-909R-F
A21R33-36				NOT ASSIGNED		
A21R37	0757-0418	9		RESISTOR 619 1% .125W F TC=0+100	24546	C4-1/8-T0-619R-F
A21R38	0757-0278	9	1	RESISTOR 1.78K 1% .125W F TC=0+100	24546	C4-1/8-T0-1781-F
A21R39				NOT ASSIGNED		
A21R40	0698-3136	8	1	RESISTOR 17.8K 1% .125W F TC=0+100	24546	C4-1/8-T0-1782-F
A21R41	0757-1094	9	1	RESISTOR 1.47K 1% .125W F TC=0+100	24546	C4-1/8-T0-1471-F
A21R42	0757-0442	9	2	RESISTOR 10K 1% .125W F TC=0+100	24546	C4-1/8-T0-1002-F
A21R43	0757-0442	9		RESISTOR 10K 1% .125W F TC=0+100	24546	C4-1/8-T0-1002-F
A21R44	0757-0280	3		RESISTOR 1K 1% .125W F TC=0+100	24546	C4-1/8-T0-1001-F
A21R45	0698-0083	8		RESISTOR 1.96K 1% .125W F TC=0+100	24546	C4-1/8-T0-1961-F
A21TP1	0360-0535	0	5	TERMINAL TEST POINT PCB	00000	ORDER BY DESCRIPTION
A21TP2	0360-0535	0		TERMINAL TEST POINT PCB	00000	ORDER BY DESCRIPTION
A21TP3	0360-0535	0		TERMINAL TEST POINT PCB	00000	ORDER BY DESCRIPTION
A21TP4	0360-0535	0		TERMINAL TEST POINT PCB	00000	ORDER BY DESCRIPTION
A21TP5	0360-0535	0		TERMINAL TEST POINT PCB	00000	ORDER BY DESCRIPTION
A21U1	1820-1197	9	1	IC GATE TTL LS NAND QUAD 2-INP	01295	SN74LS00N
A21U2	1820-1423	4	1	IC MV TTL LS MONOSTBL RETRIG DUAL	01295	SN74LS123N
A21U3	1826-0161	7	1	IC OP AMP GP QUAD 14-DIP-P PKG	04713	MLM324P

See introduction to this section for ordering information
 *Indicates factory selected value

Table 6-3. Replaceable Parts

Reference Designation	HP Part Number	C D	Qty	Description	Mfr Code	Mfr Part Number
A22				NOT ASSIGNED		
A23				NOT ASSIGNED		
A24	08340-60158	8	1	ATTENUATOR DRIVER/SRD BIAS	28480	08340-60158
A24C1	0180-0116	1	4	CAPACITOR-FXD 6.8UF+10% 35VDC TA	56289	150D685X9035B2
A24C2	0180-0116	1		CAPACITOR-FXD 6.8UF+10% 35VDC TA	56289	150D685X9035B2
A24C3	0180-0116	1		CAPACITOR-FXD 6.8UF+10% 35VDC TA	56289	150D685X9035B2
A24C4	0180-0116	1		CAPACITOR-FXD 6.8UF+10% 35VDC TA	56289	150D685X9035B2
A24C5	0160-4835	7	6	CAPACITOR-FXD .1UF +10% 50VDC CER	28480	0160-4835
A24C6	0160-4835	7		CAPACITOR-FXD .1UF +10% 50VDC CER	28480	0160-4835
A24C7	0160-4835	7		CAPACITOR-FXD .1UF +10% 50VDC CER	28480	0160-4835
A24C8	0160-4835	7		CAPACITOR-FXD .1UF +10% 50VDC CER	28480	0160-4835
A24C9	0160-4835	7		CAPACITOR-FXD .1UF +10% 50VDC CER	28480	0160-4835
A24C10	0160-4835	7		CAPACITOR-FXD .1UF +10% 50VDC CER	28480	0160-4835
A24C11	0180-0228	6	1	CAPACITOR-FXD 22UF+10% 15VDC TA	56289	150D226X9015B2
A24C12	0160-4832	4	1	CAPACITOR-FXD .01UF +10% 100VDC CER	28480	0160-4832
A24C13	0180-0049	9	1	CAPACITOR-FXD 20UF+75-10% 50VDC AL	56289	30D206G050CC2
A24C14	0160-3335	0	1	CAPACITOR-FXD 470PF +10% 100VDC CER	28480	0160-3335
A24C15	0160-4787	8	1	CAPACITOR-FXD 22PF +5% 100VDC CER 0+30	28480	0160-4787
A24C16	0160-4812	0	1	CAPACITOR-FXD 220PF +5% 100VDC CER	28480	0160-4812
A24C17, 18				NOT ASSIGNED		
A24C19	0160-0575	4	5	CAPACITOR-FXD .047UF +20% 50VDC CER	28480	0160-0575
A24C20	0160-0575	4		CAPACITOR-FXD .047UF +20% 50VDC CER	28480	0160-0575
A24C21	0160-0575	4		CAPACITOR-FXD .047UF +20% 50VDC CER	28480	0160-0575
A24C22	0160-0575	4		CAPACITOR-FXD .047UF +20% 50VDC CER	28480	0160-0575
A24C23	0160-0575	4		CAPACITOR-FXD .047UF +20% 50VDC CER	28480	0160-0575
A24C24	0160-4389	6		CAPACITOR-FXD 100PF +5PF 100VDC CER	28480	0160-4389
A24CR1	1901-0050	3	2	DIODE-SWITCHING 80V 200MA 2NS DO-35	28480	1901-0050
A24CR2	1901-0050	3		DIODE-SWITCHING 80V 200MA 2NS DO-35	28480	1901-0050
A24L1	9140-0129	1	4	INDUCTOR RF-CH-MLD 220UH 5% .166DX.385LG	28480	9140-0129
A24L2	9140-0129	1		INDUCTOR RF-CH-MLD 220UH 5% .166DX.385LG	28480	9140-0129
A24L3	9140-0129	1		INDUCTOR RF-CH-MLD 220UH 5% .166DX.385LG	28480	9140-0129
A24L4	9140-0129	1		INDUCTOR RF-CH-MLD 220UH 5% .166DX.385LG	28480	9140-0129
A24L5	9100-0539	3	1	INDUCTOR (MISC ITEM)	28480	9100-0539
A24MP1				NOT ASSIGNED		
A24MP2	4040-0750	7	1	EXTR-PC BD RED POLYC .062-BD-THKNS	28480	4040-0750
A24MP3	4040-0752	9	1	EXTR-PC BD YEL POLYC .062-BD-THKNS	28480	4040-0752
A24MP4	1480-0073	6	2	PIN-ROLL .062-IN-DIA .25-IN-LG BE-CU	28480	1480-0073
A24MP5, 6				NOT ASSIGNED		
A24MP7	1205-0033	6	1	HEAT SINK TO-5/TO-39-CS	28480	1205-0033
A24Q1	1853-0281	9	4	TRANSISTOR PNP 2N2907A SI TO-18 PD=400MW	04713	2N2907A
A24Q2	1853-0281	9		TRANSISTOR PNP 2N2907A SI TO-18 PD=400MW	04713	2N2907A
A24Q3	1853-0281	9		TRANSISTOR PNP 2N2907A SI TO-18 PD=400MW	04713	2N2907A
A24Q4	1855-0386	9	3	TRANSISTOR J-FET 2N4392 N-CHAN D-MODE	04713	2N4392
A24Q5	1855-0386	9		TRANSISTOR J-FET 2N4392 N-CHAN D-MODE	04713	2N4392
A24Q6	1855-0386	9		TRANSISTOR J-FET 2N4392 N-CHAN D-MODE	04713	2N4392
A24Q7	1854-0475	5	1	TRANSISTOR-DUAL NPN PD=750MW	28480	1854-0475
A24Q8	1855-0420	2	1	TRANSISTOR J-FET 2N4391 N-CHAN D-MODE	01295	2N4391
A24Q9	1853-0213	4	1	TRANSISTOR PNP SI TO-39 PD=1W FT=100MHZ	28480	1853-0213
A24Q10	1853-0281	9		TRANSISTOR PNP 2N2907A SI TO-18 PD=400MW	28480	1853-0281
A24R1	2100-3274	2	2	RESISTOR-TRMR 10K 10% C SIDE-ADJ 1-TRN	28480	2100-3274
A24R2	2100-3274	2		RESISTOR-TRMR 10K 10% C SIDE-ADJ 1-TRN	28480	2100-3274
A24R3	2100-3353	8	9	RESISTOR-TRMR 20K 10% C SIDE-ADJ 1-TRN	28480	2100-3353
A24R4	2100-3353	8		RESISTOR-TRMR 20K 10% C SIDE-ADJ 1-TRN	28480	2100-3353
A24R5	2100-3353	8		RESISTOR-TRMR 20K 10% C SIDE-ADJ 1-TRN	28480	2100-3353
A24R6	2100-3353	8		RESISTOR-TRMR 20K 10% C SIDE-ADJ 1-TRN	28480	2100-3353
A24R7	2100-3353	8		RESISTOR-TRMR 20K 10% C SIDE-ADJ 1-TRN	28480	2100-3353
A24R8	2100-3353	8		RESISTOR-TRMR 20K 10% C SIDE-ADJ 1-TRN	28480	2100-3353
A24R9	2100-3353	8		RESISTOR-TRMR 20K 10% C SIDE-ADJ 1-TRN	28480	2100-3353
A24R10	2100-3353	8		RESISTOR-TRMR 20K 10% C SIDE-ADJ 1-TRN	28480	2100-3353
A24R11	2100-3353	8		RESISTOR-TRMR 20K 10% C SIDE-ADJ 1-TRN	28480	2100-3353
A24R12	2100-3351	6	1	RESISTOR-TRMR 500 10% C SIDE-ADJ 1-TRN	28480	2100-3351
A24R13	0698-3453	2	6	RESISTOR 196K 1% .125W F TC=0+100	24546	C4-1/8-T0-1963-F
A24R14	0698-3453	2		RESISTOR 196K 1% .125W F TC=0+100	24546	C4-1/8-T0-1963-F
A24R15	0698-3453	2		RESISTOR 196K 1% .125W F TC=0+100	24546	C4-1/8-T0-1963-F
A24R16	0698-3453	2		RESISTOR 196K 1% .125W F TC=0+100	24546	C4-1/8-T0-1963-F
A24R17	0698-3453	2		RESISTOR 196K 1% .125W F TC=0+100	24546	C4-1/8-T0-1963-F
A24R18	0698-3453	2		RESISTOR 196K 1% .125W F TC=0+100	24546	C4-1/8-T0-1963-F
A24R19	0698-3449	6	3	RESISTOR 28.7K 1% .125W F TC=0+100	24546	C4-1/8-T0-2872-F
A24R20	0698-3449	6		RESISTOR 28.7K 1% .125W F TC=0+100	24546	C4-1/8-T0-2872-F

See introduction to this section for ordering information
 *Indicates factory selected value

Table 6-3. Model 8340A Replaceable Parts

Reference Designation	HP Part Number	C D	Qty	Description	Mfr Code	Mfr Part Number
A24R21	0698-3449	6		RESISTOR 28.7K 1% .125W F TC=0+100	24546	C4-1/8-T0-2872-F
A24R22				NOT ASSIGNED		
A24R23	0757-0442	9	9	RESISTOR 10K 1% .125W F TC=0+100	24546	C4-1/8-T0-1002-F
A24R24	0757-0442	9		RESISTOR 10K 1% .125W F TC=0+100	24546	C4-1/8-T0-1002-F
A24R25	0757-0442	9		RESISTOR 10K 1% .125W F TC=0+100	24546	C4-1/8-T0-1002-F
A24R26	0757-0442	9		RESISTOR 10K 1% .125W F TC=0+100	24546	C4-1/8-T0-1002-F
A24R27	0757-0442	9		RESISTOR 10K 1% .125W F TC=0+100	24546	C4-1/8-T0-1002-F
A24R28	0757-0442	9		RESISTOR 10K 1% .125W F TC=0+100	24546	C4-1/8-T0-1002-F
A24R29	0757-0442	9		RESISTOR 10K 1% .125W F TC=0+100	24546	C4-1/8-T0-1002-F
A24R30	0757-0442	9		RESISTOR 10K 1% .125W F TC=0+100	24546	C4-1/8-T0-1002-F
A24R31	0757-0442	9		RESISTOR 10K 1% .125W F TC=0+100	24546	C4-1/8-T0-1002-F
A24R32	0757-0443	0	1	RESISTOR 11K 1% .125W F TC=0+100	24546	C4-1/8-T0-1102-F
A24R33	0698-3151	7	1	RESISTOR 2.87K 1% .125W F TC=0+100	24546	C4-1/8-T0-2871-F
A24R34	0698-0083	8	2	RESISTOR 1.96K 1% .125W F TC=0+100	24546	C4-1/8-T0-1961-F
A24R35	0698-0083	8		RESISTOR 1.96K 1% .125W F TC=0+100	24546	C4-1/8-T0-1961-F
A24R36	0698-3156	2	2	RESISTOR 14.7K 1% .125W F TC=0+100	24546	C4-1/8-T0-1472-F
A24R37	0698-3156	2		RESISTOR 14.7K 1% .125W F TC=0+100	24546	C4-1/8-T0-1472-F
A24R38	0698-7278	7	1	RESISTOR 56.2K 1% .05W F TC=0+100	28480	0698-7278
A24R39	0757-0394	0	1	RESISTOR 51.1K 1% .125W F TC=0+100	24546	C4-1/8-T0-5111-F
A24R40	0698-3160	8	1	RESISTOR 31.6K 1% .125W F TC=0+100	24546	C4-1/8-T0-3162-F
A24R41	0757-0280	3	2	RESISTOR 1K 1% .125W F TC=0+100	24546	C4-1/8-T0-1001-F
A24R42	0698-6624	5	1	RESISTOR 2K 1% .125W F TC=0+25	28480	0698-6624
A24R43	0811-3575	1	1	RESISTOR- 3K OHM 2% .12W	28480	0811-3575
A24R44	0757-0280	3		RESISTOR 1K 1% .125W F TC=0+100	24546	C4-1/8-T0-1001-F
A24R45	0698-8827	4	1	RESISTOR 1M 1% .125W F TC=0+100	28480	0698-8827
A24R46	0757-0401	0	1	RESISTOR 100 1% .125W F TC=0+100	24546	C4-1/8-T0-101-F
A24R47	0698-0085	0	1	RESISTOR 2.61K 1% .125W F TC=0+100	24546	C4-1/8-T0-2611-F
A24R48	0698-3162	0	1	RESISTOR 46.4K 1% .125W F TC=0+100	24546	C4-1/8-T0-4642-F
A24R49	0699-0068	1	1	RESISTOR- 1.47 MEGOHM 1% .12W	28480	0699-0068
A24R50	0757-0465	6	5	RESISTOR 100K 1% .125W F TC=0+100	24546	C4-1/8-T0-1003-F
A24R51	0757-0465	6		RESISTOR 100K 1% .125W F TC=0+100	24546	C4-1/8-T0-1003-F
A24R52	0757-0465	6		RESISTOR 100K 1% .125W F TC=0+100	24546	C4-1/8-T0-1003-F
A24R53	0757-0465	6		RESISTOR 100K 1% .125W F TC=0+100	24546	C4-1/8-T0-1003-F
A24R54	0757-0465	6		RESISTOR 100K 1% .125W F TC=0+100	24546	C4-1/8-T0-1003-F
A24R55	0757-0279	0	1	RESISTOR 3.16K 1% .125W F TC=0+100	24546	C4-1/8-T0-3161-F
A24R56	0757-0416	7	1	RESISTOR 511 1% .125W F TC=0+100	24546	C4-1/8-T0-5110-F
A24R57	0757-0441	8	1	RESISTOR 8.25K 1% .125W F TC=0+100	24546	C4-1/8-T0-8251-F
A24R58	0757-0444	1	1	RESISTOR 12.1K 1% .125W F TC=0+100	24546	C4-1/8-T0-1212-F
A24R59	0757-0278	9	1	RESISTOR 1.78K 1% .125W F TC=0+100	24546	C4-1/8-T0-1781-F
A24R60	0757-0438	3	1	RESISTOR 5.11K 1% .125W F TC=0+100	24546	C4-1/8-T0-5111-F
A24R61	0698-7205	0	1	RESISTOR 51.1K 1% .125W F TC=0+100	24546	C4-1/8-T0-5111-F
A24TP1	0360-0535	0	12	TERMINAL TEST POINT PCB	00000	ORDER BY DESCRIPTION
A24TP2	0360-0535	0		TERMINAL TEST POINT PCB	00000	ORDER BY DESCRIPTION
A24TP3	0360-0535	0		TERMINAL TEST POINT PCB	00000	ORDER BY DESCRIPTION
A24TP4	0360-0535	0		TERMINAL TEST POINT PCB	00000	ORDER BY DESCRIPTION
A24TP5	0360-0535	0		TERMINAL TEST POINT PCB	00000	ORDER BY DESCRIPTION
A24TP6	0360-0535	0		TERMINAL TEST POINT PCB	00000	ORDER BY DESCRIPTION
A24TP7	0360-0535	0		TERMINAL TEST POINT PCB	00000	ORDER BY DESCRIPTION
A24TP8	0360-0535	0		TERMINAL TEST POINT PCB	00000	ORDER BY DESCRIPTION
A24TP9	0360-0535	0		TERMINAL TEST POINT PCB	00000	ORDER BY DESCRIPTION
A24TP10	0360-0535	0		TERMINAL TEST POINT PCB	00000	ORDER BY DESCRIPTION
A24TP11	0360-0535	0		TERMINAL TEST POINT PCB	00000	ORDER BY DESCRIPTION
A24TP12	0360-0535	0		TERMINAL TEST POINT PCB	00000	ORDER BY DESCRIPTION
A24U1	1826-0785	1	1	IC OP AMP LOW-BIAS-H-IMPD DUAL 8-DIP-C	01295	TL072ACJG
A24U2	1826-0828	3	2	IC-15G M1 OP AMP	06665	OP-15GJ
A24U3	1826-0828	3		IC-15G M1 OP AMP	06665	OP-15GJ
A24U4	1826-0261	8	1	IC OP AMP LOW-NOISE TO-99 PKG	28480	1826-0261
A24U5	1820-1216	3	1	IC DCDR TTL LS 3-TO-8-LINE 3-INP	01295	SN74LS138N
A24U6	1810-0395	6	1	NETWORK-RES 8-SIP47.0K OHM X 7	11236	750-81-R47K
A24U7	1826-0138	8	2	IC COMPARATOR GP QUAD 14-DIP-P PKG	01295	LM339N
A24U8	1820-0535	7	4	IC DRVR TTL AND DUAL 2-INP	01295	SN75451BP
A24U9	1820-0535	7		IC DRVR TTL AND DUAL 2-INP	01295	SN75451BP
A24U10	1820-0535	7		IC DRVR TTL AND DUAL 2-INP	01295	SN75451BP
A24U11	1820-0535	7		IC DRVR TTL AND DUAL 2-INP	01295	SN75451BP
A24U12	1826-0138	8		IC COMPARATOR GP QUAD 14-DIP-P PKG	01295	LM339N
A24U13	1906-0074	1	1	DIODE-ARRAY 50V 400MA	28480	1906-0074
A24U14	1820-1491	6	1	IC BFR TTL LS NON-INV HEX 1-INP	01295	SN74LS367AN
A24U15	1820-1195	7	1	IC FF TTL LS D-TYPE POS-EDGE-TRIG COM	01295	SN74LS175N

See introduction to this section for ordering information
 *Indicates factory selected value

Table 6-3. Replaceable Parts

Reference Designation	HP Part Number	C D	Qty	Description	Mfr Code	Mfr Part Number
A25	08340-60020	3	1	ALC DETECTOR	28480	08340-60020
A25C1	0160-4535	4	8	CAPACITOR-FXD 1UF +10% 50VDC CER	28480	0160-4535
A25C2	0160-0575	4	5	CAPACITOR-FXD .047UF +20% 50VDC CER	28480	0160-0575
A25C3	0160-4385	2	1	CAPACITOR-FXD 15PF +5% 200VDC CER 0+30	28480	0160-4385
A25C4	0160-0575	4		CAPACITOR-FXD .047UF +20% 50VDC CER	28480	0160-0575
A25C5	0160-4535	4		CAPACITOR-FXD 1UF +10% 50VDC CER	28480	0160-4535
A25C6	0160-4535	4		CAPACITOR-FXD 1UF +10% 50VDC CER	28480	0160-4535
A25C7	0160-0575	4		CAPACITOR-FXD .047UF +20% 50VDC CER	28480	0160-0575
A25C8	0160-4387	4	1	CAPACITOR-FXD 47PF +5% 200VDC CER 0+30	28480	0160-4387
A25C9	0160-3879	7	4	CAPACITOR-FXD .01UF +20% 100VDC CER	28480	0160-3879
A25C10	0160-3878	6		CAPACITOR-FXD 1000PF +20% 100VDC CER	28480	0160-3878
A25C11*	0160-3878	6	5	CAPACITOR-FXD 1000PF +20% 100VDC CER	28480	0160-3878
A25C12	0160-4389	6	1	CAPACITOR-FXD 100PF +5PF 200VDC CER	28480	0160-4389
A25C13	0160-3878	6		CAPACITOR-FXD 1000PF +20% 100VDC CER	28480	0160-3878
A25C14	0160-0575	4		CAPACITOR-FXD .047UF +20% 50VDC CER	28480	0160-0575
A25C15	0160-3879	7		CAPACITOR-FXD .01UF +20% 100VDC CER	28480	0160-3879
A25C16	0160-3879	7		CAPACITOR-FXD .01UF +20% 100VDC CER	28480	0160-3879
A25C17	0160-4084	8	4	CAPACITOR-FXD .1UF +20% 50VDC CER	28480	0160-4084
A25C18	0160-3874	2	1	CAPACITOR-FXD 10PF +.5PF 200VDC CER	28480	0160-3874
A25C19	0160-3873	1	3	CAPACITOR-FXD 4.7PF +.5PF 200VDC CER	28480	0160-3873
A25C20	0160-3873	1		CAPACITOR-FXD 4.7PF +.5PF 200VDC CER	28480	0160-3873
A25C21	0160-4084	8		CAPACITOR-FXD .1UF +20% 50VDC CER	28480	0160-4084
A25C22	0160-4084	8		CAPACITOR-FXD .1UF +20% 50VDC CER	28480	0160-4084
A25C23	0160-4084	8		CAPACITOR-FXD .1UF +20% 50VDC CER	28480	0160-4084
A25C24	0160-4789	0	1	CAPACITOR-FXD 15PF 100VDC	28480	0160-4789
A25C25	0160-0153	4	1	CAPACITOR-FXD 1000PF +10% 200VDC POLYE	28480	0160-0153
A25C26	0160-3878	6		CAPACITOR-FXD 1000PF +20% 100VDC CER	28480	0160-3878
A25C27	0160-3875	3	1	CAPACITOR-FXD 22PF +5% 200VDC CER 0+30	28480	0160-3875
A25C28	0180-2208	6	1	CAPACITOR-FXD 220UF+10% 10VDC TA	56289	150D227X9010S2
A25C29	0160-4535	4		CAPACITOR-FXD 1UF +10% 50VDC CER	28480	0160-4535
A25C30	0160-4535	4		CAPACITOR-FXD 1UF +10% 50VDC CER	28480	0160-4535
A25C31	0180-0116	1	1	CAPACITOR-FXD 6.8UF+10% 35VDC TA	56289	150D685X9035B2
A25C32	0160-4535	4		CAPACITOR-FXD 1UF +10% 50VDC CER	28480	0160-4535
A25C33-35				NOT ASSIGNED		
A25C36	0160-3878	6		CAPACITOR-FXD 1000PF +20% 100VDC CER	28480	0160-3878
A25C37	0160-3405	5	1	CAPACITOR-FXD 2UF +10% 50VDC MET-POLYC	28480	0160-3405
A25C38	0160-3873	1		CAPACITOR-FXD 4.7PF +.5PF 200VDC CER	28480	0160-3873
A25C39	0160-0575	4		CAPACITOR-FXD .047UF +20% 50VDC CER	28480	0160-0575
A25C40	0160-3879	7		CAPACITOR-FXD .01UF +20% 100VDC CER	28480	0160-3879
A25C41	0160-4535	4		CAPACITOR-FXD 1UF +10% 50VDC CER	28480	0160-4535
A25C42	0160-4535	4		CAPACITOR-FXD 1UF +10% 50VDC CER	28480	0160-4535
A25CR1	1901-0539	3	5	DIODE-SM SIG SCHOTTKY	28480	1901-0539
A25CR2	1901-0539	3		DIODE-SM SIG SCHOTTKY	28480	1901-0539
A25CR3	1901-0539	3		DIODE-SM SIG SCHOTTKY	28480	1901-0539
A25CR4	1901-0050	3	2	DIODE-SWITCHING 80V 200MA 2NS DO-35	28480	1901-0050
A25CR5	1901-0050	3		DIODE-SWITCHING 80V 200MA 2NS DO-35	28480	1901-0050
A25CR6	1901-0539	3		DIODE-SM SIG SCHOTTKY	28480	1901-0539
A25CR7	1901-0376	6	1	DIODE-GEN PRP 35V 50MA DO-35 (RECOMMENDED REPLACEMENT)	28480	1901-0376
A25CR8	1901-0376	6	4	DIODE-GEN PRP 35V 50MA DO-35 (RECOMMENDED REPLACEMENT)	28480	1901-0376
A25CR9	1901-0033	2	3	DIODE-GEN PRP 180V 200MA DO-7	28480	1901-0033
A25CR10	1901-0033	2		DIODE-GEN PRP 180V 200MA DO-7	28480	1901-0033
A25CR11	1901-0033	2		DIODE-GEN PRP 180V 200MA DO-7	28480	1901-0033
A25CR12	1901-0539	3		DIODE-SM SIG SCHOTTKY	28480	1901-0539
A25J1	1250-0691	7	2	CONNECTOR-RF M SMB	28480	1250-0691
A25J2	1250-0691	7		CONNECTOR-RF M SMB	28480	1250-0691
A25L1	9100-3562	8	2	COIL-4.7 UH 5%	28480	9100-3562
A25L2	9100-3562	8		COIL-4.7 UH 5%	28480	9100-3562
A25MP1				NOT ASSIGNED		
A25MP2	4040-0750	7	1	EXTR-PC BD RED POLYC .062-BD-THKNS	28480	4040-0750
A25MP3	4040-0753	0	1	EXTR-PC BD GRN POLYC .062-BD-THKNS	28480	4040-0753
A25MP4	1480-0073	6	2	PIN-ROLL .062-IN-DIA .25-IN-LG BE-CU	28480	1480-0073
A25MP5	08340-20184	6	1	COMPARTMENT FILTER	28480	08340-20184
A25MP6	08340-20054	9	1	COVER-FILTER	28480	08340-20054
A25MP7	08340-00054	7	1	COVER-FILTER	28480	08340-00054
A25MP8-15	2200-0103	2	8	SCREW-MACH 4-40 .25-IN-LG PAN-HD-POZI	00000	ORDER BY DESCRIPTION
A25MP16, 17	2190-0124	4	2	WASHER-LK INTL T NO. 10 .195-IN-ID	28480	2190-0124
A25MP18, 19	2950-0078	9	2	NUT-HEX-DBL-CHAM 10-32-THD .067-IN-THK	28480	2950-0078
A25Q1	1855-0276	6	2	TRANSISTOR J-FET 2N4416A N-CHAN D-MODE	01295	2N4416A
A25Q2	1855-0276	6		TRANSISTOR J-FET 2N4416A N-CHAN D-MODE	01295	2N4416A
A25Q3	1854-0477	7	3	TRANSISTOR NPN 2N2222A SI TO-18 PD=500MW	04713	2N2222A
A25Q4	1853-0405	9	3	TRANSISTOR PNP SI PD=300MW FT=850MHZ	04713	2N4209
A25Q5	1854-0295	7	2	TRANSISTOR-DUAL NPN PD=400MW	28480	1854-0295

See introduction to this section for ordering information
*Indicates factory selected value

Table 6-3. Model 8340A Replaceable Parts

Reference Designation	HP Part Number	C D	Qty	Description	Mfr Code	Mfr Part Number
A25Q6	1853-0075	9	1	TRANSISTOR-DUAL PNP PD=400MW	28480	1853-0075
A25Q7	1854-0345	8	4	TRANSISTOR NPN 2N5179 SI TO-72 PD=200MW	04713	2N5179
A25Q8	1854-0345	8		TRANSISTOR NPN 2N5179 SI TO-72 PD=200MW	04713	2N5179
A25Q9	1854-0345	8		TRANSISTOR NPN 2N5179 SI TO-72 PD=200MW	04713	2N5179
A25Q10	1854-0477	7		TRANSISTOR NPN 2N2222A SI TO-18 PD=500MW	04713	2N2222A
A25Q11	1854-0477	7		TRANSISTOR NPN 2N2222A SI TO-18 PD=500MW	04713	2N2222A
A25Q12	1855-0235	7	2	TRANSISTOR J-FET N-CHAN D-MODE TO-52 SI	28480	1855-0235
A25Q13	1854-0546	1	2	TRANSISTOR NPN SI TO-72 PD=200MW	28480	1854-0546
A25Q14	1854-0546	1		TRANSISTOR NPN SI TO-72 PD=200MW	28480	1854-0546
A25Q15	1855-0235	7		TRANSISTOR J-FET N-CHAN D-MODE TO-52 SI	28480	1855-0235
A25Q16	1854-0295	7		TRANSISTOR-DUAL NPN PD=400MW	28480	1854-0295
A25Q17	1854-0475	5	2	TRANSISTOR-DUAL NPN PD=750MW	28480	1854-0475
A25Q18	1853-0451	5	2	TRANSISTOR PNP 2N3799 SI TO-18 PD=360MW	01295	2N3799
A25Q19	1853-0451	5		TRANSISTOR PNP 2N3799 SI TO-18 PD=360MW	01295	2N3799
A25Q20	1854-0688	2	1	TRANSISTOR-DUAL NPN TO-71	28480	1854-0688
A25Q21	1854-0475	5		TRANSISTOR-DUAL NPN PD=750MW	28480	1854-0475
A25Q22	1853-0269	3	1	TRANSISTOR-DUAL PNP 2N3809 PD=600MW	01295	2N3809
A25Q23	1854-0345	8		TRANSISTOR NPN 2N5179 SI TO-72 PD=200MW	04713	2N5179
A25Q24	1853-0281	9	1	TRANSISTOR PNP 2N2907A SI TO-18 PD=400MW	04713	2N2907A
A25Q25	1855-0414	4	1	TRANSISTOR J-FET 2N4393 N-CHAN D-MODE	04713	2N4393
A25Q26	1853-0316	1	1	TRANSISTOR-DUAL PNP PD=500MW	28480	1853-0316
A25Q27	1855-0386	9	3	TRANSISTOR J-FET 2N4392 N-CHAN D-MODE	04713	2N4392
A25Q28	1855-0386	9		TRANSISTOR J-FET 2N4392 N-CHAN D-MODE	04713	2N4392
A25Q29	1855-0386	9		TRANSISTOR J-FET 2N4392 N-CHAN D-MODE	04713	2N4392
A25Q30	1853-0405	9		TRANSISTOR PNP SI PD=300MW FT=850MHZ	04713	2N4209
A25Q31	1853-0405	9		TRANSISTOR PNP SI PD=300MW FT=850MHZ	04713	2N4209
A25R1	0698-7284	5	3	RESISTOR 100K 1% .05W F TC=0+100	24546	C3-1/8-T0-1003-F
A25R2	0698-7284	5		RESISTOR 100K 1% .05W F TC=0+100	24546	C3-1/8-T0-1003-F
A25R3	0698-7212	9	3	RESISTOR 100 1% .05W F TC=0+100	24546	C3-1/8-T0-100R-F
A25R4	0698-8827	4	2	RESISTOR 1M 1% .125W F TC=0+100	28480	0698-8827
A25R5	0698-7264	1	1	RESISTOR 14.7K 1% .05W F TC=0+100	24546	C3-1/8-T0-1472-F
A25R6	0698-7212	9		RESISTOR 100 1% .05W F TC=0+100	24546	C3-1/8-T0-100R-F
A25R7	0698-3429	2	2	RESISTOR 19.6 1% .125W F TC=0+100	03888	PME55-1/8-T0-19R6-F
A25R8	0698-0082	7	3	RESISTOR 464 1% .125W F TC=0+100	24546	C4-1/8-T0-4640-F
A25R9	0757-0280	3	4	RESISTOR 1K 1% .125W F TC=0+100	24546	C4-1/8-T0-1001-F
A25R10	0757-0420	3	2	RESISTOR 750 1% .125W F TC=0+100	24546	C4-1/8-T0-751-F
A25R11	0757-0280	3		RESISTOR 1K 1% .125W F TC=0+100	24546	C4-1/8-T0-1001-F
A25R12	0757-0280	3		RESISTOR 1K 1% .125W F TC=0+100	24546	C4-1/8-T0-1001-F
A25R13	0757-0424	7	2	RESISTOR 1.1K 1% .125W F TC=0+100	24546	C4-1/8-T0-1101-F
A25R14	0698-3154	0	4	RESISTOR 4.22K 1% .125W F TC=0+100	24546	C4-1/8-T0-4221-F
A25R15	0698-7209	4	3	RESISTOR 75 1% .05W F TC=0+100	24546	C3-1/8-T0-75R0-F
A25R16	0698-3154	0		RESISTOR 4.22K 1% .125W F TC=0+100	24546	C4-1/8-T0-4221-F
A25R17	0757-0424	7		RESISTOR 1.1K 1% .125W F TC=0+100	24546	C4-1/8-T0-1101-F
A25R18	0698-3429	2		RESISTOR 19.6 1% .125W F TC=0+100	03888	PME55-1/8-T0-19R6-F
A25R19	0698-7212	9		RESISTOR 100 1% .05W F TC=0+100	24546	C3-1/8-T0-100R-F
A25R20	0698-7209	4		RESISTOR 75 1% .05W F TC=0+100	24546	C3-1/8-T0-75R0-F
A25R21	0698-7209	4		RESISTOR 75 1% .05W F TC=0+100	24546	C3-1/8-T0-75R0-F
A25R22	0698-0083	8	3	RESISTOR 1.96K 1% .125W F TC=0+100	24546	C4-1/8-T0-1961-F
A25R23	0698-8821	8	1	RESISTOR 5.62 1% .125W F TC=0+100	28480	0698-8821
A25R24	2100-0589	6	1	RESISTOR-TRMR 10 10% C SIDE-ADJ 1-TRN	28480	2100-0589
A25R25	0698-7188	8	1	RESISTOR 10 1% .05W F TC=0+100	24546	C3-1/8-T0-10R-F
A25R26	0757-0459	8	1	RESISTOR 56.2K 1% .125W F TC=0+100	24546	C4-1/8-T0-5622-F
A25R27	0757-0419	0	2	RESISTOR 681 1% .125W F TC=0+100	24546	C4-1/8-T0-681R-F
A25R28	0698-3161	9	1	RESISTOR 38.3K 1% .125W F TC=0+100	24546	C4-1/8-T0-3832-F
A25R29	0698-3440	7	1	RESISTOR 196 1% .125W F TC=0+100	24546	C4-1/8-T0-196R-F
A25R30	0757-0460	1	1	RESISTOR 61.9K 1% .125W F TC=0+100	24546	C4-1/8-T0-6192-F
A25R31	0698-3157	3	4	RESISTOR 19.6K 1% .125W F TC=0+100	24546	C4-1/8-T0-1962-F
A25R32	0698-3157	3		RESISTOR 19.6K 1% .125W F TC=0+100	24546	C4-1/8-T0-1962-F
A25R33	2100-1762	9	4	RESISTOR-TRMR 20K 5% WW SIDE-ADJ 1-TRN	28480	2100-1762
A25R34	2100-1762	9		RESISTOR-TRMR 20K 5% WW SIDE-ADJ 1-TRN	28480	2100-1762
A25R35	0811-3596	6	1	RESISTOR- 320 OHM 2% .12W	28480	0811-3596
A25R36*	0757-0438	3	4	RESISTOR 5.11K 1% .125W F TC=0+100	24546	C4-1/8-T0-5111-F
A25R37*	0698-3154	0		RESISTOR 4.22K 1% .125W F TC=0+100	24546	C4-1/8-T0-4221-F
A25R38	2100-1759	4	2	RESISTOR-TRMR 2K 5% WW SIDE-ADJ 1-TRN	28480	2100-1759
A25R39	2100-1759	4		RESISTOR-TRMR 2K 5% WW SIDE-ADJ 1-TRN	28480	2100-1759
A25R40	0757-0418	9	2	RESISTOR 619 1% .125W F TC=0+100	24546	C4-1/8-T0-619R-F
A25R41	0757-0290	5	1	RESISTOR 6.19K 1% .125W F TC=0+100	19701	MF4C1/8-T0-6191-F
A25R42	0698-6320	8	3	RESISTOR 5K .1% .125W F TC=0+25	03888	PME55-1/8-T9-5001-B
A25R43	0757-0317	7	1	RESISTOR 1.33K 1% .125W F TC=0+100	24546	C4-1/8-T0-1331-F
A25R44	0698-6320	8		RESISTOR 5K .1% .125W F TC=0+25	03888	PME55-1/8-T9-5001-B
A25R45	0698-3152	8	2	RESISTOR 3.48K 1% .125W F TC=0+100	24546	C4-1/8-T0-3481-F
A25R46	0757-0279	0	1	RESISTOR 3.16K 1% .125W F TC=0+100	24546	C4-1/8-T0-3161-F
A25R47	0698-3438	3	1	RESISTOR 147 1% .125W F TC=0+100	24546	C4-1/8-T0-147R-F
A25R48	0757-0438	3		RESISTOR 5.11K 1% .125W F TC=0+100	24546	C4-1/8-T0-5111-F

See introduction to this section for ordering information
 *Indicates factory selected value

Table 6-3. Model 8340A Replaceable Parts

Reference Designation	HP Part Number	C D	Qty	Description	Mfr Code	Mfr Part Number
A25R49	0757-0438	3		RESISTOR 5.11K 1% .125W F TC=0+100	24546	C4-1/8-T0-5111-F
A25R50	0698-6377	5	1	RESISTOR 200 .1% .125W F TC=0+25	28480	0698-6377
A25R51	0757-0199	3	2	RESISTOR 21.5K 1% .125W F TC=0+100	24546	C4-1/8-T0-2152-F
A25R52	0699-1056	9	1	RESISTOR- 825 OHM .1% .12W	28480	0699-1056
A25R53	0757-0274	5	2	RESISTOR 1.21K 1% .125W F TC=0+100	24546	C4-1/8-T0-1211-F
A25R54	0698-0083	8		RESISTOR 1.96K 1% .125W F TC=0+100	24546	C4-1/8-T0-1961-F
A25R55	0757-0401	0	1	RESISTOR 100 1% .125W F TC=0+100	24546	C4-1/8-T0-101-F
A25R56	0757-0428	1	1	RESISTOR 1.62K 1% .125W F TC=0+100	24546	C4-1/8-T0-1621-F
A25R57	0698-3439	4	1	RESISTOR 178 1% .125W F TC=0+100	24546	C4-1/8-T0-178R-F
A25R58	2100-3351	6	1	RESISTOR-TRMR 500 10% C SIDE-ADJ 1-TRN	28480	2100-3351
A25R59	0757-0418	9		RESISTOR 619 1% .125W F TC=0+100	24546	C4-1/8-T0-619R-F
A25R60	0698-0082	7		RESISTOR 464 1% .125W F TC=0+100	24546	C4-1/8-T0-4640-F
A25R61	0698-3157	3		RESISTOR 19.6K 1% .125W F TC=0+100	24546	C4-1/8-T0-1962-F
A25R62	0757-0200	7	1	RESISTOR 5.62K 1% .125W F TC=0+100	24546	C4-1/8-T0-5621-F
A25R63	0698-0082	7		RESISTOR 464 1% .125W F TC=0+100	24546	C4-1/8-T0-4640-F
A25R64	0811-3575	1	2	RESISTOR- 3K OHM 2% .12W	28480	0811-3575
A25R65	0698-6624	5	2	RESISTOR 2K .1% .125W F TC=0+25	28480	0698-6624
A25R66	0811-3576	2	1	RESISTOR- 533 OHM 2% .12W	28480	0811-3576
A25R67	0699-0793	9	1	RESISTOR- 33.2K OHM .1% .12W	28480	0699-0793
A25R68	0757-0464	5	1	RESISTOR 90.9K 1% .125W F TC=0+100	24546	C4-1/8-T0-9092-F
A25R69	0698-6376	4	2	RESISTOR 200K .1% .125W F TC=0+25	19701	MF4C1/8-T9-2003-B
A25R70	0698-6376	4		RESISTOR 200K .1% .125W F TC=0+25	19701	MF4C1/8-T9-2003-B
A25R71	0698-3151	7	1	RESISTOR 2.87K 1% .125W F TC=0+100	24546	C4-1/8-T0-2871-F
A25R72	0698-3160	8	1	RESISTOR 31.6K .1% .125W F TC=0+25	28480	0698-3160
A25R73	0757-0346	2	3	RESISTOR 10 1% .125W F TC=0+100	24546	C4-1/8-T0-10R0-F
A25R74	0757-0280	3		RESISTOR 1K 1% .125W F TC=0+100	24546	C4-1/8-T0-1001-F
A25R75	0698-8827	4		RESISTOR 1M 1% .125W F TC=0+100	28480	0698-8827
A25R76	0698-3155	1	1	RESISTOR 4.64K 1% .125W F TC=0+100	24546	C4-1/8-T0-4641-F
A25R77	0698-3153	9	1	RESISTOR 3.83K 1% .125W F TC=0+100	24546	C4-1/8-T0-3831-F
A25R78	0757-0346	2		RESISTOR 10 1% .125W F TC=0+100	24546	C4-1/8-T0-10R0-F
A25R79	0698-3453	2	2	RESISTOR 196K 1% .125W F TC=0+100	24546	C4-1/8-T0-1963-F
A25R80	2100-1762	9		RESISTOR-TRMR 20K 5% WW SIDE-ADJ 1-TRN	28480	2100-1762
A25R81	0757-0419	0		RESISTOR 681 1% .125W F TC=0+100	24546	C4-1/8-T0-681R-F
A25R82	0757-0346	2		RESISTOR 10 1% .125W F TC=0+100	24546	C4-1/8-T0-10R0-F
A25R83	0698-3453	2		RESISTOR 196K 1% .125W F TC=0+100	24546	C4-1/8-T0-1963-F
A25R84	2100-1762	9		RESISTOR-TRMR 20K 5% WW SIDE-ADJ 1-TRN	28480	2100-1762
A25R85	0698-3446	3	1	RESISTOR 383 1% .125W F TC=0+100	24546	C4-1/8-T0-383R-F
A25R86	0757-1094	9	2	RESISTOR 1.47K 1% .125W F TC=0+100	24546	C4-1/8-T0-1471-F
A25R87	0698-3157	3		RESISTOR 19.6K 1% .125W F TC=0+100	24546	C4-1/8-T0-1962-F
A25R88	2100-0552	3	1	RESISTOR-TRMR 50 10% C SIDE-ADJ 1-TRN	28480	2100-0552
A25R89	0698-3154	0		RESISTOR 4.22K 1% .125W F TC=0+100	24546	C4-1/8-T0-4221-F
A25R90	0698-3152	8		RESISTOR 3.48K 1% .125W F TC=0+100	24546	C4-1/8-T0-3481-F
A25R91	0757-0465	6	5	RESISTOR 100K 1% .125W F TC=0+100	24546	C4-1/8-T0-1003-F
A25R92	0698-3458	7	1	RESISTOR 348K 1% .125W F TC=0+100	28480	0698-3458
A25R93	0699-0794	0	1	RESISTOR- 1.07K OHM .1% .12W	28480	0699-0794
A25R94	0698-6360	6	1	RESISTOR 10K .1% .125W F TC=0+25	28480	0698-6360
A25R95	0698-6362	8	1	RESISTOR 1K .1% .125W F TC=0+25	28480	0698-6362
A25R96	0757-0465	6		RESISTOR 100K 1% .125W F TC=0+100	24546	C4-1/8-T0-1003-F
A25R97	0757-0465	6		RESISTOR 100K 1% .125W F TC=0+100	24546	C4-1/8-T0-1003-F
A25R98	0757-0465	6		RESISTOR 100K 1% .125W F TC=0+100	24546	C4-1/8-T0-1003-F
A25R99	0698-6320	8		RESISTOR 5K .1% .125W F TC=0+25	03888	PME55-1/8-T9-5001-B
A25R100	0698-6624	5		RESISTOR 2K .1% .125W F TC=0+25	28480	0698-6624
A25R101	0811-3575	1		RESISTOR- 3K OHM 2% .12W	28480	0811-3575
A25R102	0698-3136	8	1	RESISTOR 17.8K 1% .125W F TC=0+100	24546	C4-1/8-T0-1782-F
A25R103	0757-1094	9		RESISTOR 1.47K 1% .125W F TC=0+100	24546	C4-1/8-T0-1471-F
A25R104	0757-0274	5		RESISTOR 1.21K 1% .125W F TC=0+100	24546	C4-1/8-T0-1211-F
A25R105	0698-0084	9	1	RESISTOR 2.15K 1% .125W F TC=0+100	24546	C4-1/8-T0-2151-F
A25R106	0698-3158	4	1	RESISTOR 23.7K 1% .125W F TC=0+100	24546	C4-1/8-T0-2372-F
A25R107	0757-0465	6		RESISTOR 100K 1% .125W F TC=0+100	24546	C4-1/8-T0-1003-F
A25R108	2100-1760	7	1	RESISTOR-TRMR 5K 5% WW SIDE-ADJ 1-TRN	28480	2100-1760
A25R109*	0698-0083	8		RESISTOR 1.96K 1% .125W F TC=0+100	24546	C4-1/8-T0-1961-F
A25R110	0698-7284	5		RESISTOR 100K 1% .05W F TC=0+100	24546	C3-1/8-T0-1003-F
A25R111	0757-0442	9	2	RESISTOR 10K 1% .125W F TC=0+100	24546	C4-1/8-T0-1002-F
A25R112	0757-0442	9		RESISTOR 10K 1% .125W F TC=0+100	24546	C4-1/8-T0-1002-F
A25R113	0757-0420	3		RESISTOR 750 1% .125W F TC=0+100	24546	C4-1/8-T0-751-F
A25R114				NOT ASSIGNED		
A25R115*	0757-0438	3		RESISTOR 5.11K 1% .125W F TC=0+100	24546	C4-1/8-T0-5111-F
A25R116	0757-0199	3		RESISTOR 21.5K 1% .125W F TC=0+100	24546	C4-1/8-T0-2152-F
A25R117	0757-0440	7	1	RESISTOR 7.5K 1% .125W F TC=0+100	24546	C4-1/8-T0-7501-F
A25TP1	0360-0535	0	7	TERMINAL TEST POINT PCB	00000	ORDER BY DESCRIPTION
A25TP2	0360-0535	0		TERMINAL TEST POINT PCB	00000	ORDER BY DESCRIPTION
A25TP3	0360-0535	0		TERMINAL TEST POINT PCB	00000	ORDER BY DESCRIPTION
A25TP4	0360-0535	0		TERMINAL TEST POINT PCB	00000	ORDER BY DESCRIPTION
A25TP5	0360-0535	0		TERMINAL TEST POINT PCB	00000	ORDER BY DESCRIPTION

See introduction to this section for ordering information
 *Indicates factory selected value

Table 6-3. Model 8340A Replaceable Parts

Reference Designation	HP Part Number	C D	Qty	Description	Mfr Code	Mfr Part Number
A25TP6	0360-0535	0		TERMINAL TEST POINT PCB	00000	ORDER BY DESCRIPTION
A25TP7	0360-0535	0		TERMINAL TEST POINT PCB	00000	ORDER BY DESCRIPTION
A25U1	1826-0845	4	1	IC OP AMP PRCN TO-99 PKG	06665	OP-07EJ
A25U2	1826-0306	2	2	IC COMPARATOR GP QUAD 14-DIP-C PKG	27014	LM339AJ
A25U3	1826-0471	2	4	IC OP AMP LOW-DRIFT TO-99 PKG	28480	1826-0471
A25U4	1826-0785	1	2	IC OP AMP LOW-BIAS-H-IMPD DUAL 8-DIP-C	01295	TL072ACJG
A25U5	1826-0785	1		IC OP AMP LOW-BIAS-H-IMPD DUAL 8-DIP-C	01295	TL072ACJG
A25U6	1826-0471	2		IC OP AMP LOW-DRIFT TO-99 PKG	28480	1826-0471
A25U7	1826-0471	2		IC OP AMP LOW-DRIFT TO-99 PKG	28480	1826-0471
A25U8	1826-0601	0	1	IC OP AMP PRCN TO-99 PKG	06665	OP-16FJ
A25U9	1826-0306	2		IC COMPARATOR GP QUAD 14-DIP-C PKG	27014	LM339AJ
A25U10	1826-0471	2		IC OP AMP LOW-DRIFT TO-99 PKG	28480	1826-0471

See introduction to this section for ordering information
 *Indicates factory selected value

Table 6-3. Replaceable Parts

Reference Designation	HP Part Number	C D	Qty	Description	Mfr Code	Mfr Part Number
A26	08340-60212	5	1	LINEAR MODULATOR	28480	08340-60212
A26C1	0160-4811	9	1	CAPACITOR-FXD 270PF +-5% 100VDC CER	28480	0160-4811
A26C2	0160-4385	2	1	CAPACITOR-FXD 15PF +-5% 200VDC CER 0+-30	28480	0160-4385
A26C3	0160-0575	4	10	CAPACITOR-FXD .047UF +-20% 50VDC CER	28480	0160-0575
A26C4	0160-0575	4	4	CAPACITOR-FXD .047UF +-20% 50VDC CER	28480	0160-0575
A26C5	0160-4791	4	1	CAPACITOR-FXD 10PF +-5% 100VDC CER 0+-30	28480	0160-4791
A26C6	0160-0153	4	1	CAPACITOR-FXD 1000PF +-10% 200VDC POLYE	28480	0160-0153
A26C7	0160-0162	5	1	CAPACITOR-FXD .022UF +-10% 200VDC POLYE	28480	0160-0162
A26C8	0160-0575	4	4	CAPACITOR-FXD .047UF +-20% 50VDC CER	28480	0160-0575
A26C9	0160-0575	4	4	CAPACITOR-FXD .047UF +-20% 50VDC CER	28480	0160-0575
A26C10	0160-4389	6	2	CAPACITOR-FXD 100PF +-5PF 200VDC CER	28480	0160-4389
A26C11	0160-0575	4		CAPACITOR-FXD .047UF +-20% 50VDC CER	28480	0160-0575
A26C12	0160-0575	4		CAPACITOR-FXD .047UF +-20% 50VDC CER	28480	0160-0575
A26C13	0160-4386	3	1	CAPACITOR-FXD 33PF +-5% 200VDC CER 0+-30	28480	0160-4386
A26C14	0160-4389	6		CAPACITOR-FXD 100PF +-5PF 200VDC CER	28480	0160-4389
A26C15	0160-0156	7	1	CAPACITOR-FXD 3900PF +-10% 200VDC POLYE	28480	0160-0156
A26C16	0160-3878	6	1	CAPACITOR-FXD 1000PF +-20% 100VDC CER	28480	0160-3878
A26C17	0160-4535	4	8	CAPACITOR-FXD 1UF +-10% 50VDC CER	28480	0160-4535
A26C18	0160-4535	4		CAPACITOR-FXD 1UF +-10% 50VDC CER	28480	0160-4535
A26C19	0160-4835	7	2	CAPACITOR-FXD .1UF +-10% 50VDC CER	28480	0160-4835
A26C20	0160-5098	6	2	CAPACITOR-CER .22UF 50VDC	16299	CAC05X7R224J050A
A26C21	0160-4835	7		CAPACITOR-FXD .1UF +-10% 50VDC CER	28480	0160-4835
A26C22	0160-5098	6		CAPACITOR-CER .22UF 50VDC	16299	CAC05X7R224J050A
A26C23	0160-4535	4		CAPACITOR-FXD 1UF +-10% 50VDC CER	28480	0160-4535
A26C24	0160-4535	4		CAPACITOR-FXD 1UF +-10% 50VDC CER	28480	0160-4535
A26C25	0160-4535	4		CAPACITOR-FXD 1UF +-10% 50VDC CER	28480	0160-4535
A26C26	0160-4535	4		CAPACITOR-FXD 1UF +-10% 50VDC CER	28480	0160-4535
A26C27	0160-4535	4		CAPACITOR-FXD 1UF +-10% 50VDC CER	28480	0160-4535
A26C28	0160-4535	4		CAPACITOR-FXD 1UF +-10% 50VDC CER	28480	0160-4535
A26C29	0160-4825	5	1	CAPACITOR-FXD 560PF +-5% 100VDC CER	28480	0160-4825
A26C30	0160-3879	7	1	CAPACITOR-FXD .01UF +-20% 100VDC CER	28480	0160-3879
A26C31	0160-0575	4		CAPACITOR-FXD .047UF +-20% 50VDC CER	28480	0160-0575
A26C32	0160-0575	4		CAPACITOR-FXD .047UF +-20% 50VDC CER	28480	0160-0575
A26C33	0160-0575	4		CAPACITOR-FXD .047UF +-20% 50VDC CER	28480	0160-0575
A26C34	0160-0575	4		CAPACITOR-FXD .047UF +-20% 50VDC CER	28480	0160-0575
A26C35				NOT ASSIGNED		
A26C36	0160-4825	5	1	CAPACITOR-FXD 560PF +-5% 100VDC CER	28480	0160-4825
A26CR1	1901-0033	2	9	DIODE-GEN PRP 180V 200MA DO-7	28480	1901-0033
A26CR2	1901-0033	2		DIODE-GEN PRP 180V 200MA DO-7	28480	1901-0033
A26CR3	1901-0050	3	5	DIODE-SWITCHING 80V 200MA 2NS DO-35	28480	1901-0050
A26CR4	1901-0033	2		DIODE-GEN PRP 180V 200MA DO-7	28480	1901-0033
A26CR5	1901-0033	2		DIODE-GEN PRP 180V 200MA DO-7	28480	1901-0033
A26CR6	1901-0033	2		DIODE-GEN PRP 180V 200MA DO-7	28480	1901-0033
A26CR7	1901-0539	3	2	DIODE-SM SIG SCHOTTKY	28480	1901-0539
A26CR8	1901-0539	3		DIODE-SM SIG SCHOTTKY	28480	1901-0539
A26CR9				NOT ASSIGNED		
A26CR10	1901-0050	3		DIODE-SWITCHING 180V 200MA 2NS DO-35	28480	1901-0050
A26CR11	1901-0033	2		DIODE-GEN PRP 180V 200MA DO-7	28480	1901-0033
A26CR12	1901-0033	2		DIODE-GEN PRP 180V 200MA DO-7	28480	1901-0033
A26CR13	1901-0050	3		DIODE-SWITCHING 80V 200MA 2NS DO-35	28480	1901-0050
A26CR14	1901-0050	3		DIODE-SWITCHING 80V 200MA 2NS DO-35	28480	1901-0050
A26L1	9100-1643	2	1	INDUCTOR RF-CH-MLD 300UH 5% .2DX.45LG	28480	9100-1643
A26L2	9140-0112	2	5	INDUCTOR RF-CH-MLD 4.7UH 10%	28480	9140-0112
A26L3	9140-0112	2		INDUCTOR RF-CH-MLD 4.7UH 10%	28480	9140-0112
A26L4	9140-0112	2		INDUCTOR RF-CH-MLD 4.7UH 10%	28480	9140-0112
A26L5	9140-0112	2		INDUCTOR RF-CH-MLD 4.7UH 10%	28480	9140-0112
A26L6	9140-0112	2		INDUCTOR RF-CH-MLD 4.7UH 10%	28480	9140-0112
A26L7	9100-1666	9	1	INDUCTOR RF-CH-MLD 3.6MH 5%	28480	9100-1666
A26MP1	4040-0750	7	1	EXTR-PC BD RED POLYC .062-BD-THKNS	28480	4040-0750
A26MP2	4040-0754	1	1	EXTR-PC BD BLU POLYC .062-BD-THKNS	28480	4040-0754
A26MP3, 4	1480-0073	6	2	PIN-ROLL .062-IN-DIA .25-IN-LG BE-CU	28480	1480-0073
A26Q1	1855-0420	2	1	TRANSISTOR J-FET 2N4391 N-CHAN D-MODE	01295	2N4391
A26Q2	1855-0414	4	10	TRANSISTOR J-FET 2N4393 N-CHAN D-MODE	04713	2N4393
A26Q3	1855-0414	4		TRANSISTOR J-FET 2N4393 N-CHAN D-MODE	04713	2N4393
A26Q4	1855-0414	4		TRANSISTOR J-FET 2N4393 N-CHAN D-MODE	04713	2N4393
A26Q5	1855-0414	4		TRANSISTOR J-FET 2N4393 N-CHAN D-MODE	04713	2N4393
A26Q6	1855-0414	4		TRANSISTOR J-FET 2N4393 N-CHAN D-MODE	04713	2N4393
A26Q7	1853-0451	5	2	TRANSISTOR PNP 2N3799 SI TO-18 PD=360MW	01295	2N3799
A26Q8	1853-0388	7	1	TRANSISTOR-DUAL PNP PD=600MW	28480	1853-0388
A26Q9	1854-0477	7		TRANSISTOR NPN 2N2222A SI TO-18 PD=500MW	04713	2N2222A
A26Q10	1855-0414	4		TRANSISTOR J-FET 2N4393 N-CHAN D-MODE	04713	2N4393
A26Q11	1853-0405	9	3	TRANSISTOR NPN SI TO-39 PD=1W FT=25 MHZ	02037	2N4209
A26Q12	1853-0405	9		TRANSISTOR NPN SI TO-39 PD=1W FT=25 MHZ	02037	2N4209
A26Q13	1853-0405	9		TRANSISTOR NPN SI TO-39 PD=1W FT=25 MHZ	02037	2N4209
A26Q14	1855-0421	3	4	TRANSISTOR J-FET 2N5114 P-CHAN D-MODE	17856	2N5114
A26Q15	1854-0475	5	1	TRANSISTOR-DUAL NPN PD=750MW	28480	1854-0475
A26Q16	1855-0386	9	2	TRANSISTOR J-FET 2N4392 N-CHAN D-MODE	04713	2N4392

See introduction to this section for ordering information.

*Indicates factory selected value.

Table 6-3. Replaceable Parts

Reference Designation	HP Part Number	C D	Qty	Description	Mfr Code	Mfr Part Number
A26Q17	1854-0477	7	5	TRANSISTOR NPN 2N2222A SI TO-18 PD=500MW	04713	2N2222A
A26Q18	1853-0281	9		TRANSISTOR PNP 2N2907A SI TO-18 PD=400MW	04713	2N2907A
A26Q19	1855-0414	4		TRANSISTOR J-FET 2N4393 N-CHAN D-MODE	04713	2N4393
A26Q20	1855-0414	4		TRANSISTOR J-FET 2N4393 N-CHAN D-MODE	04713	2N4393
A26Q21	1855-0421	3	1	TRANSISTOR J-FET 2N5114 P-CHAN D-MODE	17856	2N5114
A26Q22	1855-0421	3		TRANSISTOR J-FET 2N5114 P-CHAN D-MODE	17856	2N5114
A26Q23	1855-0386	9		TRANSISTOR J-FET 2N4392 N-CHAN D-MODE	04713	2N4392
A26Q24	1854-0475	5		TRANSISTOR-DUAL NPN PD=750MW	28480	1854-0475
A26Q25	1853-0451	5		TRANSISTOR PNP 2N3799 SI TO-18 PD=360MW	01295	2N3799
A26Q26	1854-0477	7	2	TRANSISTOR NPN 2N2222A SI TO-18 PD=500MW	04713	2N2222A
A26Q27	1853-0281	9		TRANSISTOR PNP 2N2907A SI TO-18 PD=400MW	04713	2N2907A
A26Q28	1855-0278	8		TRANSISTOR J-FET 2N5116 P-CHAN D-MODE	17856	2N5116
A26Q29	1855-0421	3		TRANSISTOR J-FET 2N5114 P-CHAN D-MODE	17856	2N5114
A26Q30	1855-0414	4		TRANSISTOR J-FET 2N4393 N-CHAN D-MODE	04713	2N4393
A26Q31	1854-0477	7	7	TRANSISTOR NPN 2N2222A SI TO-18 PD=500MW	04713	2N2222A
A26Q32	1854-0477	7		TRANSISTOR NPN 2N2222A SI TO-18 PD=500MW	04713	2N2222A
A26R1	0698-6362	8	2	RESISTOR 1K .1% .125W F TC=0+-25	28480	0698-6362
A26R2	0698-3450	9		RESISTOR 42.2K 1% .125W F TC=0+-100	24546	C4-1/8-T0-4222-F
A26R3	0698-8861	6		RESISTOR 6.66K .1% .125W F TC=0+-25	28480	0698-8861
A26R4	0757-0346	2		RESISTOR 10 1% .125W F TC=0+-100	24546	C4-1/8-T0-10R0-F
A26R5	0698-3136	8		RESISTOR 17.8K 1% .125W F TC=0+-100	24546	C4-1/8-T0-1782-F
A26R6	0757-0442	9	10	RESISTOR 10K 1% .125W F TC=0+-100	24546	C4-1/8-T0-1002-F
A26R7	2100-3274	2		RESISTOR-TRMR 10K 10% C SIDE-ADJ 1-TRN	28480	2100-3274
A26R8	0698-3151	7		RESISTOR 2.87K 1% .125W F TC=0+-100	24546	C4-1/8-T0-2871-F
A26R9	0757-0260	3		RESISTOR 1K 1% .125W F TC=0+-100	24546	C4-1/8-T0-1001-F
A26R10	0757-0260	3		RESISTOR 1K 1% .125W F TC=0+-100	24546	C4-1/8-T0-1001-F
A26R11	0757-0438	3	2	RESISTOR 5.11K 1% .125W F TC=0+-100	24546	C4-1/8-T0-5111-F
A26R12	0757-0260	3		RESISTOR 1K 1% .125W F TC=0+-100	24546	C4-1/8-T0-1001-F
A26R13	0757-0279	0		RESISTOR 3.16K 1% .125W F TC=0+-100	24546	C4-1/8-T0-3161-F
A26R14	0698-3458	7		RESISTOR 348K 1% .125W F TC=0+-100	28480	0698-3458
A26R15	0757-0465	6		RESISTOR 100K 1% .125W F TC=0+-100	24546	C4-1/8-T0-1003-F
A26R16	0698-3157	3	1	RESISTOR 19.6K 1% .125W F TC=0+-100	24546	C4-1/8-T0-1962-F
A26R17	0757-0260	3		RESISTOR 1K 1% .125W F TC=0+-100	24546	C4-1/8-T0-1001-F
A26R18	0757-0346	2		RESISTOR 10 1% .125W F TC=0+-100	24546	C4-1/8-T0-10R0-F
A26R19	0698-6323	1		RESISTOR 100 .1% .125W F TC=0+-25	28480	0698-6323
A26R20	0698-6317	3		RESISTOR 500 .1% .125W F TC=0+-25	03888	PME55-1/8-T9-500R-B
A26R21	0698-6360	6	1	RESISTOR 10K .1% .125W F TC=0+-25	28480	0698-6360
A26R22	0698-4433	0		RESISTOR 2.26K 1% .125W F TC=0+-100	24546	C4-1/8-T0-2261-F
A26R23	0698-6624	5		RESISTOR 2K .1% .125W F TC=0+-25	28480	0698-6624
A26R24	0757-0442	9		RESISTOR 10K 1% .125W F TC=0+-100	24546	C4-1/8-T0-1002-F
A26R25	0757-0428	1		RESISTOR 1.62K 1% .125W F TC=0+-100	24546	C4-1/8-T0-1621-F
A26R26	0698-6363	9	2	RESISTOR 40K .1% .125W F TC=0+-25	28480	0698-6363
A26R27	0757-0428	1		RESISTOR 1.62K 1% .125W F TC=0+-100	24546	C4-1/8-T0-1621-F
A26R28	0757-0260	3		RESISTOR 1K 1% .125W F TC=0+-100	24546	C4-1/8-T0-1001-F
A26R29	0698-6363	9		RESISTOR 40K .1% .125W F TC=0+-25	28480	0698-6363
A26R30	0757-0401	0		RESISTOR 100 1% .125W F TC=0+-100	24546	C4-1/8-T0-101-F
A26R31	0757-0442	9	6	RESISTOR 10K 1% .125W F TC=0+-100	24546	C4-1/8-T0-1002-F
A26R32	0757-0279	0		RESISTOR 3.16K 1% .125W F TC=0+-100	24546	C4-1/8-T0-3161-F
A26R33	0757-0442	9		RESISTOR 10K 1% .125W F TC=0+-100	24546	C4-1/8-T0-1002-F
A26R34	0698-8827	4		RESISTOR 1M 1% .125W F TC=0+-100	28480	0698-8827
A26R35	0698-3458	7		RESISTOR 348K 1% .125W F TC=0+-100	28480	0698-3458
A26R36	0698-8827	4	1	RESISTOR 1M 1% .125W F TC=0+-100	28480	0698-8827
A26R37	0698-6364	0		RESISTOR 50 OHM .1% .125W	28480	0698-6364
A26R38	0698-6317	3		RESISTOR 500 .1% .125W F TC=0+-25	03888	PME55-1/8-T9-500R-B
A26R39	0757-0260	3		RESISTOR 1K 1% .125W F TC=0+-100	24546	C4-1/8-T0-1001-F
A26R40	0757-0465	6		RESISTOR 100K 1% .125W F TC=0+-100	24546	C4-1/8-T0-1003-F
A26R41	0757-0442	9	3	RESISTOR 10K 1% .125W F TC=0+-100	24546	C4-1/8-T0-1002-F
A26R42	0698-6362	8		RESISTOR 1K .1% .125W F TC=0+-25	28480	0698-6362
A26R43	2100-3353	8		RESISTOR-TRMR 20K 10% C SIDE-ADJ 1-TRN	28480	2100-3353
A26R44	0757-0462	3		RESISTOR 75K 1% .125W F TC=0+-100	24546	C4-1/8-T0-7502-F
A26R45	2100-3353	8		RESISTOR-TRMR 20K 10% C SIDE-ADJ 1-TRN	28480	2100-3353
A26R46	0698-0084	9	2	RESISTOR 2.15K 1% .125W F TC=0+-100	24546	C4-1/8-T0-2151-F
A26R47	2100-3354	9		RESISTOR-TRMR 50K 10% C SIDE-ADJ 1-TRN	28480	2100-3354
A26R48	0698-3156	2		RESISTOR 14.7K 1% .125W F TC=0+-100	24546	C4-1/8-T0-1472-F
A26R49	2100-3355	0		RESISTOR-TRMR 100K 10% C SIDE-ADJ 1-TRN	28480	2100-3355
A26R50	0698-3450	9		RESISTOR 42.2K 1% .125W F TC=0+-100	24546	C4-1/8-T0-4222-F
A26R51	2100-3355	0	1	RESISTOR-TRMR 100K 10% C SIDE-ADJ 1-TRN	28480	2100-3355
A26R52	0757-0442	9		RESISTOR 10K 1% .125W F TC=0+-100	24546	C4-1/8-T0-1002-F
A26R53	0757-0401	0		RESISTOR 100 1% .125W F TC=0+-100	24546	C4-1/8-T0-101-F
A26R54	0698-3136	8		RESISTOR 17.8K 1% .125W F TC=0+-100	24546	C4-1/8-T0-1782-F
A26R55	0811-3619	4		RESISTOR- 260 OHM 2% .12W	28480	0811-3619
A26R56	0757-0816	1	1	RESISTOR 681 OHM 1% .5W F TC=0+-100	28480	0757-0816
A26R57	0698-8827	4		RESISTOR 1M 1% .125W F TC=0+-100	28480	0698-8827
A26R58	0698-8861	6		RESISTOR 6.66K .1% .125W F TC=0+-25	28480	0698-8861
A26R59	0757-0462	3		RESISTOR 75K 1% .125W F TC=0+-100	24546	C4-1/8-T0-7502-F
A26R60	0698-3152	8		RESISTOR 3.48K 1% .125W F TC=0+-100	24546	C4-1/8-T0-3481-F
A26R61	0698-3159	5	2	RESISTOR 26.1K 1% .125W F TC=0+-100	24546	C4-1/8-T0-2612-F
A26R62	0698-3159	5		RESISTOR 26.1K 1% .125W F TC=0+-100	24546	C4-1/8-T0-2612-F
A26R63	0757-0401	0		RESISTOR 100 1% .125W F TC=0+-100	24546	C4-1/8-T0-101-F

See introduction to this section for ordering information.

*Indicates factory selected value.

Table 6-3. Replaceable Parts

Reference Designation	HP Part Number	C D	Qty	Description	Mfr Code	Mfr Part Number
A26R64	0757-0280	3		RESISTOR 1K 1% .125W F TC=0+-100	24546	C4-1/B-T0-1001-F
A26R65	0757-0280	3		RESISTOR 1K 1% .125W F TC=0+-100	24546	C4-1/B-T0-1001-F
A26R66	0757-0440	7	2	RESISTOR 7.5K 1% .125W F TC=0+-100	24546	C4-1/B-T0-7501-F
A26R67	0698-3156	2	1	RESISTOR 14.7K 1% .125W F TC=0+-100	24546	C4-1/B-T0-1472-F
A26R68	0698-8827	4		RESISTOR 1M 1% .125W F TC=0+-100	28480	0698-8827
A26R69	0698-8827	4		RESISTOR 1M 1% .125W F TC=0+-100	28480	0698-8827
A26R70	0757-0442	9		RESISTOR 10K 1% .125W F TC=0+-100	24546	C4-1/B-T0-1002-F
A26R71	0757-0442	9		RESISTOR 10K 1% .125W F TC=0+-100	24546	C4-1/B-T0-1002-F
A26R72	0698-8959	3	1	RESISTOR 61.9K 1% .125W F TC=0+-100	28480	0698-8959
A26R73	0698-8827	4		RESISTOR 1M 1% .125W F TC=0+-100	28480	0698-8827
A26R74	0757-0465	6		RESISTOR 100K 1% .125W F TC=0+-100	24546	C4-1/B-T0-1003-F
A26R75	0757-0438	3		RESISTOR 5.11K 1% .125W F TC=0+-100	24546	C4-1/B-T0-5111-F
A26R76	0757-0465	6		RESISTOR 100K 1% .125W F TC=0+-100	24546	C4-1/B-T0-1003-F
A26R77	0757-0460	1		RESISTOR 61.9K 1% .125W F TC=0+-100	24546	C4-1/B-T0-6192-F
A26R78	0757-0465	6		RESISTOR 100K 1% .125W F TC=0+-100	24546	C4-1/B-T0-1003-F
A26R79	0698-0083	8	1	RESISTOR 1.96K 1% .125W F TC=0+-100	24546	C4-1/B-T0-1961-F
A26R80	0757-1094	9	2	RESISTOR 1.47K 1% .125W F TC=0+-100	24546	C4-1/B-T0-1471-F
A26R81	0698-3152	8		RESISTOR 3.48K 1% .125W F TC=0+-100	24546	C4-1/B-T0-3481-F
A26R82	0757-0280	3		RESISTOR 1K 1% .125W F TC=0+-100	24546	C4-1/B-T0-1001-F
A26R83	0757-0280	3		RESISTOR 1K 1% .125W F TC=0+-100	24546	C4-1/B-T0-1001-F
A26R84	0757-0442	9		RESISTOR 10K 1% .125W F TC=0+-100	24546	C4-1/B-T0-1002-F
A26R85	0698-3429	2	1	RESISTOR 19.6 1% .125W F TC=0+-100	03888	PME55-1/B-T0-19R6-F
A26R86	0698-3157	3	1	RESISTOR 19.6K 1% .125W F TC=0+-100	24546	C4-1/B-T0-1962-F
A26R87	0811-3575	1	1	RESISTOR- 3K OHM 2% .12W	28480	0811-3575
A26R88	2100-3353	8		RESISTOR-TRMR 20K 10% C SIDE-ADJ 1-TRN	28480	2100-3353
A26R89	0757-0416	7	1	RESISTOR 511 1% .125W F TC=0+-100	24546	C4-1/B-T0-511R-F
A26R90	0757-1094	9		RESISTOR 1.47K 1% .125W F TC=0+-100	24546	C4-1/B-T0-1471-F
A26R91	2100-3350	5	1	RESISTOR-TRMR 200 10% C SIDE-ADJ 1-TRN	28480	2100-3350
A26R92	0698-0084	9		RESISTOR 2.15K 1% .125W F TC=0+-100	24546	C4-1/B-T0-2151-F
A26R93	0757-0444	1	1	RESISTOR 12.1K 1% .125W F TC=0+-100	24546	C4-1/B-T0-1212-F
A26R94	0757-0465	6		RESISTOR 100K 1% .125W F TC=0+-100	03292	C4-1/B-T0-1003-F
A26R95	0698-0085	0	1	RESISTOR 2.61K 1% .125W F TC=0+-100	03292	C4-1/B-T0-2611-F
A26R96	2100-3757	6	1	RESISTOR-TRMR 100 10% C SIDE-ADJ 17 TRN	04568	67XR100
A26R97	0698-3443	0	1	RESISTOR 287 OHM 1% .125W F TC=0+-100	03292	C4-1/B-T0-287R-F
A26R98	0698-0082	7	1	RESISTOR 464 OHM 1% .125W F TC=0+-100	03292	C4-1/B-T0-4640-F
A26R99	0757-0441	8	1	RESISTOR 8.25K 1% .125W F TC=0+-100	24546	C4-1/B-T0-8251-F
A26R100	0698-0084	9		RESISTOR 2.15K 1% .125W F TC=0+-100	24546	C4-1/B-T0-2151-F
A26TP1-5	0360-0535	0	5	TERMINAL TEST POINT PCB	00000	ORDER BY DESCRIPTION
A26U1	1826-0601	0	3	IC OP AMP PRCN TO-99 PKG	06665	OP-16FJ
A26U2	1826-1007	2	1	IC- 27G M1 OP AMP	28480	1826-1007
A26U3	1826-0306	2	3	IC COMPARTOR GP QUAD 14-DIP-C PKG	27014	LM339AJ
A26U4	1820-1216	3	1	IC DCDR TTL LS 3-TO-B-LINE 3-INP	01295	SN74LS138N
A26U5	1810-0371	8	1	RESISTIVE NETWORK-100K OHM 8 PINS	01121	208A 104
A26U6	1826-0306	2		IC COMPARTOR GP QUAD 14-DIP-C PKG	27014	LM339AJ
A26U7	1828-0828	3	1	IC- 15G M1 OP AMP	06665	OP-15GJ
A26U8	1826-0601	0		IC OP AMP PRCN TO-99 PKG	06665	OP-16FJ
A26U9	1826-0306	2		IC COMPARTOR GP QUAD 14-DIP-C PKG	27014	LM339AJ
A26U10	1820-1197	9	1	IC GATE TTL LS NAND QUAD 2-INP	01295	SN74LS00N
A26U11	1826-0161	7	1	IC OP AMP GP QUAD 14-DIP-P PKG	04713	MLM324P
A26U12	1826-0601	0		IC OP AMP PRCN TO-99 PKG	06665	OP-16FJ
A26U13	1826-0026	3	2	IC COMPARTOR PRCN TO-99 PKG	01295	LM311L
A26U14	1826-0026	3		IC COMPARTOR PRCN TO-99 PKG	01295	LM311L
A26U15	1820-1730	6	1	IC FF TTL LS D-TYPE POS-EDGE-TRIG COM	01295	SN74LS273N
A26W1	8159-0005	0	1	RESISTOR-ZERO OHMS 22 AWG LEAD DIA	28480	8159-0005

See introduction to this section for ordering information.

*Indicates factory selected value.

Table 6-3. Model 8340A Replaceable Parts

Reference Designation	HP Part Number	C D	Qty	Description	Mfr Code	Mfr Part Number
A27	08340-60022	5	1	LEVEL CONTROL	28480	08340-60022
A27C1	0160-4084	8	16	CAPACITOR-FXD .1UF +20% 50VDC CER	28480	0160-4084
A27C2	0160-4084	8		CAPACITOR-FXD .1UF +20% 50VDC CER	28480	0160-4084
A27C3	0160-3878	6	3	CAPACITOR-FXD 1000PF +20% 100VDC CER	28480	0160-3878
A27C4	0160-3876	4	3	CAPACITOR-FXD 47PF +20% 200VDC CER	28480	0160-3876
A27C5	0160-3879	7	18	CAPACITOR-FXD .01UF +20% 100VDC CER	28480	0160-3879
A27C6	0160-3879	7		CAPACITOR-FXD .01UF +20% 100VDC CER	28480	0160-3879
A27C7	0160-3879	7		CAPACITOR-FXD .01UF +20% 100VDC CER	28480	0160-3879
A27C8	0160-3879	7		CAPACITOR-FXD .01UF +20% 100VDC CER	28480	0160-3879
A27C9	0160-3878	6		CAPACITOR-FXD 1000PF +20% 100VDC CER	28480	0160-3878
A27C10	0160-3876	4		CAPACITOR-FXD 47PF +20% 200VDC CER	28480	0160-3876
A27C11	0160-4084	8		CAPACITOR-FXD .1UF +20% 50VDC CER	28480	0160-4084
A27C12	0160-4084	8		CAPACITOR-FXD .1UF +20% 50VDC CER	28480	0160-4084
A27C13	0160-3878	6		CAPACITOR-FXD 1000PF +20% 100VDC CER	28480	0160-3878
A27C14	0160-3876	4		CAPACITOR-FXD 47PF +20% 200VDC CER	28480	0160-3876
A27C15	0160-3879	7		CAPACITOR-FXD .01UF +20% 100VDC CER	28480	0160-3879
A27C16	0160-3879	7		CAPACITOR-FXD .01UF +20% 100VDC CER	28480	0160-3879
A27C17	0160-4084	8		CAPACITOR-FXD .1UF +20% 50VDC CER	28480	0160-4084
A27C18	0160-4084	8		CAPACITOR-FXD .1UF +20% 50VDC CER	28480	0160-4084
A27C19	0160-3879	7		CAPACITOR-FXD .01UF +20% 100VDC CER	28480	0160-3879
A27C20	0160-4084	8		CAPACITOR-FXD .1UF +20% 50VDC CER	28480	0160-4084
A27C21	0160-3879	7		CAPACITOR-FXD .01UF +20% 100VDC CER	28480	0160-3879
A27C22				NOT ASSIGNED		
A27C23	0160-3879	7		CAPACITOR-FXD .01UF +20% 100VDC CER	28480	0160-3879
A27C24	0160-3879	7		CAPACITOR-FXD .01UF +20% 100VDC CER	28480	0160-3879
A27C25				NOT ASSIGNED		
A27C26	0160-3879	7		CAPACITOR-FXD .01UF +20% 100VDC CER	28480	0160-3879
A27C27	0160-3879	7		CAPACITOR-FXD .01UF +20% 100VDC CER	28480	0160-3879
A27C28	0160-3879	7		CAPACITOR-FXD .01UF +20% 100VDC CER	28480	0160-3879
A27C29				NOT ASSIGNED		
A27C30	0160-3879	7		CAPACITOR-FXD .01UF +20% 100VDC CER	28480	0160-3879
A27C31	0180-2661	5	2	CAPACITOR-FXD 1UF+10% 50VDC TA	25088	D1R0GS1A50K
A27C32	0160-4846	0	1	CAPACITOR-FXD 1500PF +5% 100VDC CER	28480	0160-4846
A27C33	0160-3879	7		CAPACITOR-FXD .01UF +20% 100VDC CER	28480	0160-3879
A27C34	0160-3879	7		CAPACITOR-FXD .01UF +20% 100VDC CER	28480	0160-3879
A27C35	0160-3879	7		CAPACITOR-FXD .01UF +20% 100VDC CER	28480	0160-3879
A27C36				NOT ASSIGNED		
A27C37	0160-3879	7		CAPACITOR-FXD .01UF +20% 100VDC CER	28480	0160-3879
A27C38	0160-4084	8		CAPACITOR-FXD .1UF +20% 50VDC CER	28480	0160-4084
A27C39	0160-4084	8		CAPACITOR-FXD .1UF +20% 50VDC CER	28480	0160-4084
A27C40	0160-4084	8		CAPACITOR-FXD .1UF +20% 50VDC CER	28480	0160-4084
A27C41	0160-4084	8		CAPACITOR-FXD .1UF +20% 50VDC CER	28480	0160-4084
A27C42	0160-4084	8		CAPACITOR-FXD .1UF +20% 50VDC CER	28480	0160-4084
A27C43	0180-0630	4	2	CAPACITOR-FXD 4.7UF+20% 50VDC TA	28480	0180-0630
A27C44	0180-2661	5		CAPACITOR-FXD 1UF+10% 50VDC TA	25088	D1R0GS1A50K
A27C45	0180-0630	4		CAPACITOR-FXD 4.7UF+20% 50VDC TA	28480	0180-0630
A27C46	0160-4084	8		CAPACITOR-FXD .1UF +20% 50VDC CER	28480	0160-4084
A27C47	0180-2617	1	2	CAPACITOR-FXD 6.8UF+10% 35VDC TA	25088	D6R8GS1B35K
A27C48	0160-4084	8		CAPACITOR-FXD .1UF +20% 50VDC CER	28480	0160-4084
A27C49	0180-2697	7	1	CAPACITOR-FXD 10UF+10% 25VDC TA	28480	0180-2697
A27C50	0160-4084	8		CAPACITOR-FXD .1UF +20% 50VDC CER	28480	0160-4084
A27C51	0180-2617	1		CAPACITOR-FXD 6.8UF+10% 35VDC TA	25088	D6R8GS1B35K
A27C52	0160-4084	8		CAPACITOR-FXD .1UF +20% 50VDC CER	28480	0160-4084
A27C53	0180-0500	7	1	CAPACITOR-FXD 47UF+20% 20VDC TA	28480	0180-0500
A27C54	0160-3875	3	2	CAPACITOR-FXD 22PF +5% 200VDC CER 0+30	28480	0160-3875
A27C55	0160-3875	3		CAPACITOR-FXD 22PF +5% 200VDC CER 0-30	28480	0160-3875
A27CR1	1901-0050	3	8	DIODE-SWITCHING 80V 200MA 2NS DO-35	28480	1901-0050
A27CR2	1901-0050	3		DIODE-SWITCHING 80V 200MA 2NS DO-35	28480	1901-0050
A27CR3	1901-0050	3		DIODE-SWITCHING 80V 200MA 2NS DO-35	28480	1901-0050
A27CR4	1901-0050	3		DIODE-SWITCHING 80V 200MA 2NS DO-35	28480	1901-0050
A27CR5	1901-0050	3		DIODE-SWITCHING 80V 200MA 2NS DO-35	28480	1901-0050
A27CR6	1901-0050	3		DIODE-SWITCHING 80V 200MA 2NS DO-35	28480	1901-0050
A27CR7	1901-0050	3		DIODE-SWITCHING 80V 200MA 2NS DO-35	28480	1901-0050
A27CR8	1901-0518	8	5	DIODE-SM SIG SCHOTTKY	28480	1901-0518
A27CR9	1901-0518	8		DIODE-SM SIG SCHOTTKY	28480	1901-0518
A27CR10	1901-0518	8		DIODE-SM SIG SCHOTTKY	28480	1901-0518
A27CR11	1901-0518	8		DIODE-SM SIG SCHOTTKY	28480	1901-0518
A27CR12	1901-0518	8		DIODE-SM SIG SCHOTTKY	28480	1901-0518
A27CR13	1901-0050	3		DIODE-SWITCHING 80V 200MA 2NS DO-35	28480	1901-0050
A27DS1	1990-0486	6	1	LED-LAMP LUM-INT=LMCD IF=20MA-MAX BVR=5V	28480	5082-4684
A27L1	9140-0210	1	4	INDUCTOR RF-CH-MLD 100UH 5% .166DX.385LG	28480	9140-0210
A27L2	9140-0210	1		INDUCTOR RF-CH-MLD 100UH 5% .166DX.385LG	28480	9140-0210
A27L3	9140-0210	1		INDUCTOR RF-CH-MLD 100UH 5% .166DX.385LG	28480	9140-0210

See introduction to this section for ordering information
 *Indicates factory selected value

Table 6-3. Replaceable Parts

Reference Designation	HP Part Number	C D	Qty	Description	Mfr Code	Mfr Part Number
A27L4	9140-0114	4	1	INDUCTOR RF-CH-MLD 10UH 10% .166DX.385LG	28480	9140-0114
A27L5	9140-0210	1		INDUCTOR RF-CH-MLD 100UH 5% .166DX.385LG	28480	9140-0210
A27MP1	1200-0173	5	2	INSULATOR-XSTR DAP-GL	28480	1200-0173
A27MP2	1205-0011	0	1	HEAT SINK TO-5/TO-39-CS	28480	1205-0011
A27MP3	4040-0750	7	1	EXTR-PC BD RED POLYC .062-BD-THKNS	28480	4040-0750
A27MP4, 5	1480-0073	6	2	PIN-ROLL .062-IN-DIA .25-IN-LG BE-CU	28480	1480-0073
A27MP6	4040-0755	2	1	EXTR-PC BD VIO POLYC .062-BD-THKNS	28480	4040-0755
A27Q1	1826-0730	6	1	IC V RGLTR-V-REF-FXD 10V TO-5 PKG	28480	1826-0730
A27Q2	1854-0477	7	1	TRANSISTOR NPN 2N2222A SI TO-18 PD=500MW	04713	2N2222A
A27Q3	1826-0512	2	1	IC 78M15C V RGLTR TO-39	04713	78M15CG
A27R1	0698-6360	6	7	RESISTOR 10K .1% .125W F TC=0+25	28480	0698-6360
A27R2	0698-6360	6		RESISTOR 10K .1% .125W F TC=0+25	28480	0698-6360
A27R3	0698-6977	1	1	RESISTOR 30K .1% .125W F TC=0+25 (RECOMMENDED REPLACEMENT)	28480	0698-6977
A27R4	2100-3353	8	1	RESISTOR-TRMR 20K 10% C SIDE-ADJ 1-TRN (RECOMMENDED REPLACEMENT)	28480	2100-3353
A27R5	0698-6360	6		RESISTOR 10K .1% .125W F TC=0+25	28480	0698-6360
A27R6	0698-6360	6		RESISTOR 10K .1% .125W F TC=0+25	28480	0698-6360
A27R7	0698-3136	8	1	RESISTOR 17.8K 1% .125W F TC=0+100	24546	C4-1/8-T0-1782-F
A27R8	2100-3207	1	1	RESISTOR-TRMR 5K 10% C SIDE-ADJ 1-TRN	28480	2100-3207
A27R9	0698-6630	3	1	RESISTOR 20K .1% .125W F TC=0+25	28480	0698-6630
A27R10	0698-6320	8	2	RESISTOR 5K .1% .125W F TC=0+25	03888	PME55-1/8-T9-5001-B
A27R11	0698-6347	9	1	RESISTOR 1.5K .1% .125W F TC=0+25	28480	0698-6347
A27R12	0698-6631	4	2	RESISTOR 2.5K .1% .125W F TC=0+25	28480	0698-6631
A27R13	0698-6624	5		RESISTOR 2K .1% .125W F TC=0+25	28480	0698-6624
A27R14				NOT ASSIGNED		
A27R15	0757-0442	9	6	RESISTOR 10K 1% .125W F TC=0+100	24546	C4-1/8-T0-1002-F
A27R16	0698-6360	6		RESISTOR 10K .1% .125W F TC=0+25	28480	0698-6360
A27R17	0698-6360	6		RESISTOR 10K .1% .125W F TC=0+25	28480	0698-6360
A27R18	0698-6320	8		RESISTOR 5K .1% .125W F TC=0+25	03888	PME55-1/8-T9-5001-B
A27R19	0698-6362	8	1	RESISTOR 1K .1% .125W F TC=0+25	28480	0698-6362
A27R20	0757-0418	9	1	RESISTOR 619 1% .125W F TC=0+100	24546	C4-1/8-T0-619R-F
A27R21	0757-0421	4	1	RESISTOR 825 1% .125W F TC=0+100	24546	C4-1/8-T0-825R-F
A27R22	0698-3446	3	3	RESISTOR 383 1% .125W F TC=0+100	24546	C4-1/8-T0-383R-F
A27R23	0699-0118	2	1	RESISTOR- 20K OHM .1% .1W	28480	0699-0118
A27R24	0699-0144	4	2	RESISTOR- 10K OHM .1% .1W	28480	0699-0144
A27R25	0699-0144	4		RESISTOR- 10K OHM .1% .1W	28480	0699-0144
A27R26	0698-6360	6		RESISTOR 10K .1% .125W F TC=0+25	28480	0698-6360
A27R27				NOT ASSIGNED		
A27R28	0698-6353	7	8	RESISTOR 50K .1% .125W F TC=0+25	28480	0698-6353
A27R29	0698-6353	7		RESISTOR 50K .1% .125W F TC=0+25	28480	0698-6353
A27R30	0698-6353	7		RESISTOR 50K .1% .125W F TC=0+25	28480	0698-6353
A27R31	0698-6353	7		RESISTOR 50K .1% .125W F TC=0+25	28480	0698-6353
A27R32	0698-8191	5	1	RESISTOR 12.5K .1% .125W F TC=0+25	19701	MF4CL/8-T9-1252-B
A27R33	0698-6353	7		RESISTOR 50K .1% .125W F TC=0+25	28480	0698-6353
A27R34	0698-6977	1	1	RESISTOR 30K .1% .125W F TC=0+25	28480	0698-6977
A27R35	0698-6353	7		RESISTOR 50K .1% .125W F TC=0+25	28480	0698-6353
A27R36	0698-6353	7		RESISTOR 50K .1% .125W F TC=0+25	28480	0698-6353
A27R37				NOT ASSIGNED		
A27R38	0698-6353	7		RESISTOR 50K .1% .125W F TC=0+25	28480	0698-6353
A27R39	0757-0346	2	2	RESISTOR 10 1% .125W F TC=0+100	24546	C4-1/8-T0-10R0-F
A27R40	0757-0280	3	5	RESISTOR 1K 1% .125W F TC=0+100	24546	C4-1/8-T0-1001-F
A27R41	0757-0280	3		RESISTOR 1K 1% .125W F TC=0+100	24546	C4-1/8-T0-1001-F
A27R42	0757-0458	7	1	RESISTOR 51.1K 1% .125W F TC=0+100	24546	C4-1/8-T0-5112-F
A27R43	0698-6631	4		RESISTOR 2.5K .1% .125W F TC=0+25	28480	0698-6631
A27R44	0757-0465	6	1	RESISTOR 100K 1% .125W F TC=0+100	24546	C4-1/8-T0-1003-F
A27R45	0757-0438	3	2	RESISTOR 5.11K 1% .125W F TC=0+100	24546	C4-1/8-T0-5111-F
A27R46	0757-0280	3		RESISTOR 1K 1% .125W F TC=0+100	24546	C4-1/8-T0-1001-F
A27R47	0757-0442	9		RESISTOR 10K 1% .125W F TC=0+100	24546	C4-1/8-T0-1002-F
A27R48	0757-0398	4	2	RESISTOR 75 1% .125W F TC=0+100	24546	C4-1/8-T0-75R0-F
A27R49	0757-0442	9		RESISTOR 10K 1% .125W F TC=0+100	24546	C4-1/8-T0-1002-F
A27R50	0757-0442	9		RESISTOR 10K 1% .125W F TC=0+100	24546	C4-1/8-T0-1002-F
A27R51	0757-0422	5	2	RESISTOR 909 1% .125W F TC=0+100	24546	C4-1/8-T0-909R-F
A27R52	0698-3446	3		RESISTOR 383 1% .125W F TC=0+100	24546	C4-1/8-T0-383R-F
A27R53	0757-0422	5		RESISTOR 909 1% .125W F TC=0+100	24546	C4-1/8-T0-909R-F
A27R54	0698-3446	3		RESISTOR 383 1% .125W F TC=0+100	24546	C4-1/8-T0-383R-F
A27R55	0757-0280	3		RESISTOR 1K 1% .125W F TC=0+100	24546	C4-1/8-T0-1001-F
A27R56	0757-0346	2		RESISTOR 10 1% .125W F TC=0+100	24546	C4-1/8-T0-10R0-F
A27R57	0757-0279	0	1	RESISTOR 3.16K 1% .125W F TC=0+100	24546	C4-1/8-T0-3161-F
A27R58	0757-0444	1	1	RESISTOR 12.1K 1% .125W F TC=0+100	24546	C4-1/8-T0-1212-F
A27R59	0757-0442	9		RESISTOR 10K 1% .125W F TC=0+100	24546	C4-1/8-T0-1002-F
A27R60	0757-0398	4		RESISTOR 75 1% .125W F TC=0+100	24546	C4-1/8-T0-75R0-F
A27R61	0698-6358	2	3	RESISTOR 100K .1% .125W F TC=0+25	28480	0698-6358
A27R62	0698-6358	2		RESISTOR 100K .1% .125W F TC=0+25	28480	0698-6358

See introduction to this section for ordering information
 *Indicates factory selected value

Table 6-3. Replaceable Parts

Reference Designation	HP Part Number	C D	Qty	Description	Mfr Code	Mfr Part Number
A27R63	0698-6358	2		RESISTOR 100K 1% .125W F TC=0+25	28480	0698-6358
A27R64				NOT ASSIGNED		
A27R65	0811-3575	1	1	RESISTOR- 3K OHM 2% .12W	28480	0811-3575
A27R66	0757-0280	3		RESISTOR 1K 1% .125W F TC=0+100	24546	C4-1/8-T0-1001-F
A27R67	0757-0442	9		RESISTOR 10K 1% .125W F TC=0+100	24546	C4-1/8-T0-1002-F
A27R68	0757-0438	3		RESISTOR 5.11K 1% .125W F TC=0+100	24546	C4-1/8-T0-5111-F
A27R69	0698-8824	1	1	RESISTOR 562K 1% .125W F TC=0+100	28480	0698-8824
A27R70	0698-3150	6	1	RESISTOR 2.37K 1% .125W F TC=0+100 STANDARD INSTRUMENT	24546	C4-1/8-T0-2371-F
A27R71	0698-0085	0	1	OPTION 004 AND 005, R.P. RF OUT, REPLACE A27R70 WITH A SHORT CIRCUIT RESISTOR 2.61K 1% .125W F TC=0+100 STANDARD INSTRUMENT	24546	C4-1/8-T0-2611-F
A27RT1	0837-0105	1	1	OPTION 004 AND 005 INSTRUMENTS DELETE A27R71 THERMISTOR BEAD 200K-OHM TC=-4.9%/C-DEG	28480	0837-0105
A27TP1-21	0360-0535	0	21	TERMINAL TEST POINT PCB	00000	ORDER BY DESCRIPTION
A27U1	1820-1435	8	1	IC CNTR TTL LS BIN UP/DOWN SYNCHRO	01295	SN74LS669N
A27U2	1826-0026	3	2	IC COMPARATOR PRCN TO-99 PKG	01295	LM311L
A27U3	1826-0026	3		IC COMPARATOR PRCN TO-99 PKG	01295	LM311L
A27U4	1826-0092	3	3	IC OP AMP GP DUAL TO-99 PKG	28480	1826-0092
A27U5	1826-0092	3		IC OP AMP GP DUAL TO-99 PKG	28480	1826-0092
A27U6	1820-1415	4	1	IC SCHMITT-TRIG TTL LS NAND DUAL 4-INP	01295	SN74LS13N
A27U7	1826-0471	2	3	IC OP AMP LOW-DRIFT TO-99 PKG	28480	1826-0471
A27U8	1826-0798	6	3	IC-5018 C1 DAC	18324	NE5018F
A27U9	1826-0798	6		IC-5018 C1 DAC	18324	NE5018F
A27U10	1826-0798	6		IC-5018 C1 DAC	18324	NE5018F
A27U11	1826-0881	8	1	IC-8560 C1 ADC	28480	1826-0881
A27U12	1820-1491	6	3	IC BFR TTL LS NON-INV HEX 1-INP	01295	SN74LS367AN
A27U13	1820-1196	8	5	IC FF TTL LS D-TYPE POS-EDGE-TRIG COM	01295	SN74LS174N
A27U14	1826-0921	7	2	D/A 10-BIT 16 CBRZ/SDR CMOS (RECOMMENDED REPLACEMENT)	07050	MP7533MP
A27U15	1820-1491	6		IC BFR TTL LS NON-INV HEX 1-INP	01295	SN74LS367AN
A27U16	1820-1196	8		IC FF TTL LS D-TYPE POS-EDGE-TRIG COM	01295	SN74LS174N
A27U17	1826-0471	2		IC OP AMP LOW-DRIFT TO-99 PKG	28480	1826-0471
A27U18	1826-0092	3		IC OP AMP GP DUAL TO-99 PKG	28480	1826-0092
A27U19	1820-1297	0	1	IC GATE TTL LS EXCL-NOR QUAD 2-INP	01295	SN74LS266N
A27U20	1820-1216	3	2	IC DCDR TTL LS 3-TO-8-LINE 3-INP	01295	SN74LS138N
A27U21	1820-1112	8	1	IC FF TTL LS D-TYPE POS-EDGE-TRIG	01295	SN74LS74AN
A27U22	1820-1491	6		IC BFR TTL LS NON-INV HEX 1-INP	01295	SN74LS367AN
A27U23	1820-1196	8		IC FF TTL LS D-TYPE POS-EDGE-TRIG COM	01295	SN74LS174N
A27U24	1826-0921	7		D/A 10-BIT 16 CBRZ/SDR CMOS (RECOMMENDED REPLACEMENT)	07050	MP7533MP
A27U25	1826-0609	8	1	IC MULTIPLEXR ANLG 16-DIP-C PKG	06665	MUX08FQ
A27U26	1820-1197	9	1	IC GATE TTL LS NAND QUAD 2-INP	01295	SN74LS00N
A27U27	1820-1216	3		IC DCDR TTL LS 3-TO-8-LINE 3-INP	01295	SN74LS138N
A27U28	1820-1195	7	1	IC FF TTL LS D-TYPE POS-EDGE-TRIG COM	01295	SN74LS175N
A27U29	1820-1196	8		IC FF TTL LS D-TYPE POS-EDGE-TRIG COM	01295	SN74LS174N
A27U30	1820-1196	8		IC FF TTL LS D-TYPE POS-EDGE-TRIG COM	01295	SN74LS174N
A27U31	1826-0471	2		IC OP AMP LOW-DRIFT TO-99 PKG	28480	1826-0471
A27U32	1810-0318	3	4	RESISTIVE NETWORK- 6 PINS	01121	206A102
A27U33	1810-0318	3		RESISTIVE NETWORK- 6 PINS	01121	206A102
A27U34	1810-0318	3		RESISTIVE NETWORK- 6 PINS	01121	206A102
A27U35	1810-0318	3		RESISTIVE NETWORK- 6 PINS	01121	206A102
A27VR1	1902-3171	7	1	DIODE-2NR 11V 5% DO-35 PD=.4W TC=+.062%	28480	1902-3171

See introduction to this section for ordering information
*Indicates factory selected value

Table 6-3. Replaceable Parts

Reference Designation	HP Part Number	C D	Qty	Description	Mfr Code	Mfr Part Number
A28	08340-60159	8	1	SYTM DRIVER	28480	08340-60159
A28C1				NOT ASSIGNED		
A28C2	0160-4841	5	25	CAPACITOR-FXD .1UF +80-20% 50VDC CER	28480	0160-4841
A28C3	0160-4841	5		CAPACITOR-FXD .1UF +80-20% 50VDC CER	28480	0160-4841
A28C4	0160-4841	5		CAPACITOR-FXD .1UF +80-20% 50VDC CER	28480	0160-4841
A28C5	0160-4801	7	3	CAPACITOR-FXD 100PF +-5% 100VDC CER	28480	0160-4801
A28C6	0160-4841	5		CAPACITOR-FXD .1UF +80-20% 50VDC CER	02798	CAC325U1042050A
A28C7	0160-4841	5		CAPACITOR-FXD .1UF +80-20% 50VDC CER	28480	0160-4841
A28C8	0160-4841	5		CAPACITOR-FXD .1UF +80-20% 50VDC CER	28480	0160-4841
A28C9	0160-4801	7		CAPACITOR-FXD 100PF +-5% 100VDC CER	28480	0160-4801
A28C10, 11	0160-4841	5		CAPACITOR-FXD .1UF +80-20% 50VDC CER	02798	CAC325U1042050A
A28C12				NOT ASSIGNED		
A28C13	0160-0163	6	2	CAPACITOR-FXD .033UF +-10% 200VDC POLYE	28480	0160-0163
A28C14	0160-0163	6		CAPACITOR-FXD .033UF +-10% 200VDC POLYE	28480	0160-0163
A28C15	0160-4841	5		CAPACITOR-FXD .1UF +80-20% 50VDC CER	28480	0160-4841
A28C16	0160-4801	7		CAPACITOR-FXD 100PF +-5% 100VDC CER	28480	0160-4801
A28C17	0160-4841	5		CAPACITOR-FXD .1UF +80-20% 50VDC CER	28480	0160-4841
A28C18	0160-4841	5		CAPACITOR-FXD .1UF +80-20% 50VDC CER	28480	0160-4841
A28C19	0160-4805	1	1	CAPACITOR-FXD 47PF +-5% 100VDC CER 0+-30	28480	0160-4805
A28C20	0160-4841	5		CAPACITOR-FXD .1UF +80-20% 50VDC CER	28480	0160-4841
A28C21	0160-4841	5		CAPACITOR-FXD .1UF +80-20% 50VDC CER	28480	0160-4841
A28C22	0160-4841	5		CAPACITOR-FXD .1UF +80-20% 50VDC CER	28480	0160-4841
A28C23	0160-4841	5		CAPACITOR-FXD .1UF +80-20% 50VDC CER	28480	0160-4841
A28C24	0160-4841	5		CAPACITOR-FXD .1UF +80-20% 50VDC CER	28480	0160-4841
A28C25	0160-4841	5		CAPACITOR-FXD .1UF +80-20% 50VDC CER	28480	0160-4841
A28C26	0160-4833	5	1	CAPACITOR-FXD .022UF +-10% 100VDC CER	28480	0160-4833
A28C27				NOT ASSIGNED		
A28C28	0160-4841	5		CAPACITOR-FXD .1UF +80-20% 50VDC CER	28480	0160-4841
A28C29	0160-4841	5		CAPACITOR-FXD .1UF +80-20% 50VDC CER	28480	0160-4841
A28C30	0160-4841	5		CAPACITOR-FXD .1UF +80-20% 50VDC CER	28480	0160-4841
A28C31	0160-4841	5		CAPACITOR-FXD .1UF +80-20% 50VDC CER	28480	0160-4841
A28C32	0160-4841	5		CAPACITOR-FXD .1UF +80-20% 50VDC CER	28480	0160-4841
A28C33	0180-0269	5	4	CAPACITOR-FXD .1UF +50-10% 150VDC AL	56289	30D105G150BA2
A28C34	0160-4841	5		CAPACITOR-FXD .1UF +80-20% 50VDC CER	28480	0160-4841
A28C35	0180-0269	5		CAPACITOR-FXD .1UF +50-10% 150VDC AL	56289	30D105G150BA2
A28C36	0180-0269	5		CAPACITOR-FXD .1UF +50-10% 150VDC AL	56289	30D105G150BA2
A28C37	0180-0269	5		CAPACITOR-FXD .1UF +50-10% 150VDC AL	56289	30D105G150BA2
A28C38	0160-4841	5		CAPACITOR-FXD .1UF +80-20% 50VDC CER	28480	0160-4841
A28C39	0160-0300	3	1	CAPACITOR-FXD 2700PF +-10% 200VDC POLYE	28480	0160-0300
A28C40	0160-3572	7	1	CAPACITOR-FXD 330PF +-10% 500VDC CER	28480	0160-3572
A28C41	0160-4574	1	1	CAPACITOR-FXD 1000PF +-10% 100VDC CER	28480	0160-4574
A28CR1	1901-0033	2	3	DIODE-GEN PRP 180V 200MA DO-7	28480	1901-0033
A28CR2	1901-0033	2		DIODE-GEN PRP 180V 200MA DO-7	28480	1901-0033
A28CR3	1901-0033	2		DIODE-GEN PRP 180V 200MA DO-7	28480	1901-0033
A28CR4	1901-0518	8	4	DIODE-SM SIG SCHOTTKY	28480	1901-0518
A28CR5	1901-0518	8		DIODE-SM SIG SCHOTTKY	28480	1901-0518
A28CR6	1901-0028	5	2	DIODE-PWR RECT 400V 750MA DO-29	28480	1901-0028
A28CR7	1901-0028	5		DIODE-PWR RECT 400V 750MA DO-29	28480	1901-0028
A28CR8	1901-0518	8		DIODE-SM SIG SCHOTTKY	28480	1901-0518
A28CR9	1901-0518	8		DIODE-SM SIG SCHOTTKY	28480	1901-0518
A28CR10-14	1901-0050	3	4	DIODE-SWITCHING 80V 200MA 2NS DO-35	28480	1901-0050
A28CR15				NOT ASSIGNED		
A28CR16	1901-0050	3		DIODE-SWITCHING 80V 200MA 2NS DO-35	28480	1901-0050
A28CR17				NOT ASSIGNED		
A28CR18	1901-0050	3		DIODE-SWITCHING 80V 200MA 2NS DO-35	28480	1901-0050
A28L1	9140-0144	0	4	INDUCTOR RF-CH-MLD 4.7UH 10% .105DX.26LG	28480	9140-0144
A28L2	9140-0144	0		INDUCTOR RF-CH-MLD 4.7UH 10% .105DX.26LG	28480	9140-0144
A28L3	9140-0144	0		INDUCTOR RF-CH-MLD 4.7UH 10% .105DX.26LG	28480	9140-0144
A28L4	9140-0144	0		INDUCTOR RF-CH-MLD 4.7UH 10% .105DX.26LG	28480	9140-0144
A28MP1	4040-0750	7	1	EX TR-PC BD RED POLYC .062-BD-THKNS	28480	4040-0750
A28MP2	1205-0011	0	2	HEAT SINK TO-5/TO-39-CS	28480	1205-0011
A28MP3-8				NOT ASSIGNED		
A28MP9, 10	1480-0073	6	2	PIN-ROLL .062-IN-DIA .25-IN-LG BE-CU	28480	1480-0073
A28MP11	4040-0747	2	1	EX TR-PC BD GRA POLYC .062-BD-THKNS	28480	4040-0747
A28Q1	1854-0361	8	1	TRANSISTOR NPN 2N4239 SI TO-5 PD=6W	04713	2N4239
A28Q2	1854-0404	0	1	TRANSISTOR NPN SI TO-18 PD=360MW	28480	1854-0404
A28Q3	1855-0421	3	1	TRANSISTOR J-FET 2N5114 P-CHAN D-MODE	17956	2N5114
A28Q4	1855-0414	4	13	TRANSISTOR J-FET 2N4393 N-CHAN D-MODE	04713	2N4393
A28Q5	1855-0414	4		TRANSISTOR J-FET 2N4393 N-CHAN D-MODE	04713	2N4393
A28Q6	1853-0038	4	3	TRANSISTOR PNP SI TO-39 PD=1W FT=100MHZ	28480	1853-0038
A28Q7	1854-0475	5	3	TRANSISTOR-DUAL NPN PD=750MW	28480	1854-0475
A28Q8	1853-0316	1	1	TRANSISTOR-DUAL PNP PD=500MW	28480	1853-0316
A28Q9	1855-0414	4		TRANSISTOR J-FET 2N4393 N-CHAN D-MODE	04713	2N4393
A28Q10	1855-0414	4		TRANSISTOR J-FET 2N4393 N-CHAN D-MODE	04713	2N4393
A28Q11	1855-0414	4		TRANSISTOR J-FET 2N4393 N-CHAN D-MODE	04713	2N4393
A28Q12	1855-0414	4		TRANSISTOR J-FET 2N4393 N-CHAN D-MODE	04713	2N4393
A28Q13	1855-0414	4		TRANSISTOR J-FET 2N4393 N-CHAN D-MODE	04713	2N4393
A28Q14	1855-0414	4		TRANSISTOR J-FET 2N4393 N-CHAN D-MODE	04713	2N4393
A28Q15	1855-0414	4		TRANSISTOR J-FET 2N4393 N-CHAN D-MODE	04713	2N4393

See introduction to this section for ordering information.

*Indicates factory selected value.

Table 6-3. Replaceable Parts

Reference Designation	HP Part Number	C D	Qty	Description	Mfr Code	Mfr Part Number
A2BQ16	1855-0414	4		TRANSISTOR J-FET 2N4393 N-CHAN D-MODE	04713	2N4393
A2BQ17	1855-0414	4		TRANSISTOR J-FET 2N4393 N-CHAN D-MODE	04713	2N4393
A2BQ18	1855-0414	4		TRANSISTOR J-FET 2N4393 N-CHAN D-MODE	04713	2N4393
A2BQ19	1854-0475	5		TRANSISTOR-DUAL NPN PD=750MW	28480	1854-0475
A2BQ20	1854-0809	9	3	TRANSISTOR NPN 2N2369A SI TO-18 PD=360MW	28480	1854-0809
A2BQ21	1855-0278	8	2	TRANSISTOR J-FET 2N5116 P-CHAN D-MODE	17856	2N5116
A2BQ22	1855-0278	8		TRANSISTOR J-FET 2N5116 P-CHAN D-MODE	03714	2N5116
A2BQ23	1854-0809	9		TRANSISTOR NPN 2N2369A SI TO-18 PD=360MW	28480	1854-0809
A2BQ24	1854-0475	5		TRANSISTOR-DUAL NPN PD=750MW	28480	1854-0475
A2BQ25	1855-0414	4		TRANSISTOR J-FET 2N4393 N-CHAN D-MODE	04713	2N4393
A2BQ26	1853-0038	4		TRANSISTOR PNP SI TO-39 PD=1W FT=100MHZ	28480	1853-0038
A2BQ27	1853-0038	4		TRANSISTOR PNP SI TO-39 PD=1W FT=100MHZ	28480	1853-0038
A2BR1	2100-4004	8	4	RESISTOR-TRMR 10K 5% WW SIDE-ADJ 1-TRN	28480	2100-4004
A2BR2	2100-3094	4	3	RESISTOR-TRMR 100K 10% C SIDE-ADJ 17-TRN	02111	43P104
A2BR3	2100-3094	4		RESISTOR-TRMR 100K 10% C SIDE-ADJ 17-TRN	02111	43P104
A2BR4	2100-3161	6	2	RESISTOR-TRMR 20K 10% C SIDE-ADJ 17-TRN	02111	43P203
A2BR5	2100-3352	7	2	RESISTOR-TRMR 1K 10% C SIDE-ADJ 1-TRN	28480	2100-3352
A2BR6	2100-3094	4		RESISTOR-TRMR 100K 10% C SIDE-ADJ 17-TRN	02111	43P104
A2BR7	2100-3161	6		RESISTOR-TRMR 20K 10% C SIDE-ADJ 17-TRN	02111	43P203
A2BR8	2100-4004	8		RESISTOR-TRMR 10K 5% WW SIDE-ADJ 1-TRN	28480	2100-4004
A2BR9	2100-3352	7		RESISTOR-TRMR 1K 10% C SIDE-ADJ 1-TRN	28480	2100-3352
A2BR10	2100-3274	2	1	RESISTOR-TRMR 10K 10% C SIDE-ADJ 1-TRN	28480	2100-3274
A2BR11	0698-3637	4	1	RESISTOR 820 5% 2W MO TC=0+-200	28480	0698-3637
A2BR12	0698-6353	7	2	RESISTOR 50K .1% .125W F TC=0+-25	28480	0698-6353
A2BR13	0698-6624	5	6	RESISTOR 2K .1% .125W F TC=0+-25	28480	0698-6624
A2BR14	0757-0440	7	3	RESISTOR 7.5K 1% .125W F TC=0+-100	24546	C4-1/B-T0-7502-F
A2BR15	0757-0288	1	1	RESISTOR 9.09K 1% .125W F TC=0+-100	19701	MF4C1/B-T0-9091-F
A2BR16	0757-0346	2	22	RESISTOR 10 1% .125W F TC=0+-100	24546	C4-1/B-T0-10R0-F
A2BR17	0757-0279	0	1	RESISTOR 3.16K 1% .125W F TC=0+-100	24546	C4-1/B-T0-3161-F
A2BR18	0698-3487	2	1	RESISTOR 255 1% .125W F TC=0+-100	24546	C4-1/B-T0-255R-F
A2BR19	0757-0462	3	1	RESISTOR 75K 1% .125W F TC=0+-100	24546	C4-1/B-T0-7502-F
A2BR20	0757-0424	7	1	RESISTOR 1.1K 1% .125W F TC=0+-100	24546	C4-1/B-T0-1101-F
A2BR21	0698-3447	4	1	RESISTOR 422 1% .125W F TC=0+-100	24546	C4-1/B-T0-422R-F
A2BR22	0757-0405	4	2	RESISTOR 162 1% .125W F TC=0+-100	24546	C4-1/B-T0-162R-F
A2BR23	0698-6360	6	10	RESISTOR 10K .1% .125W F TC=0+-25	28480	0698-6360
A2BR24	0698-3162	0	6	RESISTOR 46.4K 1% .125W F TC=0+-100	24546	C4-1/B-T0-4642-F
A2BR25	0698-3156	2	3	RESISTOR 14.7K 1% .125W F TC=0+-100	24546	C4-1/B-T0-1472-F
A2BR26	0698-3150	6	1	RESISTOR 2.37K 1% .125W F TC=0+-100	24546	C4-1/B-T0-2371-F
A2BR27	0757-0442	9	5	RESISTOR 10K 1% .125W F TC=0+-100	24546	C4-1/B-T0-1002-F
A2BR28	0698-6624	5		RESISTOR 2K .1% .125W F TC=0+-25	28480	0698-6624
A2BR29	0698-6360	6		RESISTOR 10K .1% .125W F TC=0+-25	28480	0698-6360
A2BR30	0698-3442	9	1	RESISTOR 237 1% .125W F TC=0+-100	24546	C4-1/B-T0-237R-F
A2BR31	0698-6624	5		RESISTOR 2K .1% .125W F TC=0+-25	28480	0698-6624
A2BR32	0757-0438	3	3	RESISTOR 5.11K 1% .125W F TC=0+-100	24546	C4-1/B-T0-5111-F
A2BR33	0698-0083	8	1	RESISTOR 1.96K 1% .125W F TC=0+-100	24546	C4-1/B-T0-1961-F
A2BR34	0757-0416	7	1	RESISTOR 5.11 1% .125W F TC=0+-100	24546	C4-1/B-T0-511R-F
A2BR35	0698-3268	7	1	RESISTOR 11.5K 1% .125W F TC=0+-100	24546	C4-1/B-T0-1152-F
A2BR36	0698-8038	9	1	RESISTOR 5.9K .25% .125W F TC=0+-50	19701	MF4C1/B-T2-5901-C
A2BR37	0757-0447	4	1	RESISTOR 18.2K 1% .125W F TC=0+-100	24546	C4-1/B-T0-1822-F
A2BR38	0757-0394	0	2	RESISTOR 51.1 1% .125W F TC=0+-100	24546	C4-1/B-T0-51R1-F
A2BR39	0698-6360	6		RESISTOR 10K .1% .125W F TC=0+-25	28480	0698-6360
A2BR40	0698-6360	6		RESISTOR 10K .1% .125W F TC=0+-25	28480	0698-6360
A2BR41	0698-3153	9	2	RESISTOR 3.83K 1% .125W F TC=0+-100	24546	C4-1/B-T0-3831-F
A2BR42	0757-0346	2		RESISTOR 10 1% .125W F TC=0+-100	24546	C4-1/B-T0-10R0-F
A2BR43	0757-0346	2		RESISTOR 10 1% .125W F TC=0+-100	24546	C4-1/B-T0-10R0-F
A2BR44	0757-0346	2		RESISTOR 10 1% .125W F TC=0+-100	24546	C4-1/B-T0-10R0-F
A2BR45	0757-0346	2		RESISTOR 10 1% .125W F TC=0+-100	24546	C4-1/B-T0-10R0-F
A2BR46	0698-3157	3	4	RESISTOR 19.6K 1% .125W F TC=0+-100	24546	C4-1/B-T0-1962-F
A2BR47	0698-3157	3		RESISTOR 19.6K 1% .125W F TC=0+-100	24546	C4-1/B-T0-1962-F
A2BR48	0757-0440	7	2	RESISTOR 7.5K .1% .125W F TC=0+-100	24546	C4-1/B-T0-7501-F
A2BR49	0698-6320	8		RESISTOR 5K .1% .125W F TC=0+-25	03888	PME55-1/B-T9-5001-B
A2BR50	0757-0280	3	7	RESISTOR 1K 1% .125W F TC=0+-100	24546	C4-1/B-T0-1001-F
A2BR51	0757-0439	4	2	RESISTOR 6.81K 1% .125W F TC=0+-100	24546	C4-1/B-T0-6811-F
A2BR52	0698-3136	8	1	RESISTOR 17.8K 1% .125W F TC=0+-100	24546	C4-1/B-T0-1782-F
A2BR53	0698-6360	6		RESISTOR 10K .1% .125W F TC=0+-25	28480	0698-6360
A2BR54	0698-6360	6		RESISTOR 10K .1% .125W F TC=0+-25	28480	0698-6360
A2BR55	0698-6631	4	4	RESISTOR 25K .1% .125W F TC=0+-25	28480	0698-6631
A2BR56	0698-3450	9	1	RESISTOR 42.2K 1% .125W F TC=0+-100	24546	C4-1/B-T0-4222-F
A2BR57	0698-6624	5		RESISTOR 2K .1% .125W F TC=0+-25	28480	0698-6624
A2BR58	0698-6624	5		RESISTOR 2K .1% .125W F TC=0+-25	28480	0698-6624
A2BR59	0698-6624	5		RESISTOR 2K .1% .125W F TC=0+-25	28480	0698-6624
A2BR60	0698-6631	4		RESISTOR 25K .1% .125W F TC=0+-25	28480	0698-6631
A2BR61	0698-6631	4		RESISTOR 2.5K .1% .125W F TC=0+-25	28480	0698-6631
A2BR62	0698-6631	4		RESISTOR 2.5K .1% .125W F TC=0+-25	28480	0698-6631
A2BR63	0698-6353	7		RESISTOR 50K .1% .125W F TC=0+-25	28480	0698-6353
A2BR64	0698-3162	0		RESISTOR 46.4K 1% .125W F TC=0+-100	24546	C4-1/B-T0-4642-F
A2BR65	0757-0802	5	1	RESISTOR 162 1% .5W F TC=0+-100	28480	0757-0802
A2BR66	0698-3156	2		RESISTOR 14.7K 1% .125W F TC=0+-100	24546	C4-1/B-T0-1472-F

See introduction to this section for ordering information

*Indicates factory selected value

Table 6-3. Replaceable Parts

Reference Designation	HP Part Number	C D	Qty	Description	Mfr Code	Mfr Part Number
A28R67	0757-0346	2		RESISTOR 10 1% .125W F TC=0+-100	24546	C4-1/B-T0-10R0-F
A28R68	0698-8039	0	1	RESISTOR 8.87K .1% .125W F TC=0+-25	19701	MF4C1/B-T9-8871-B
A28R69	0698-8498	5	1	RESISTOR 1.02K .1% .125W F TC=0+-25	28480	0698-8498
A28R70	0698-8061	8	1	RESISTOR 8.25K .1% .125W F TC=0+-25	19701	MF4C1/B-T9-8251-B
A28R71	0698-3157	3		RESISTOR 19.6K 1% .125W F TC=0+-100	24546	C4-1/B-T0-1962-F
A28R72	0757-0394	0		RESISTOR 51.1 1% .125W F TC=0+-100	24546	C4-1/B-T0-51R1-F
A28R73	0757-0442	9		RESISTOR 10K 1% .125W F TC=0+-100	24546	C4-1/B-T0-1002-F
A28R74	0698-6363	9	2	RESISTOR 40K .1% .125W F TC=0+-25	28480	0698-6363
A28R75	0698-6363	9		RESISTOR 40K .1% .125W F TC=0+-25	28480	0698-6363
A28R76	0698-6360	6		RESISTOR 10K .1% .125W F TC=0+-25	28480	0698-6360
A28R77	0698-0084	9	2	RESISTOR 2.15K 1% .125W F TC=0+-100	24546	C4-1/B-T0-2151-F
A28R78	0698-3162	0		RESISTOR 46.4K 1% .125W F TC=0+-100	24546	C4-1/B-T0-4642-F
A28R79	0698-6360	6		RESISTOR 10K .1% .125W F TC=0+-25	28480	0698-6360
A28R80	0757-0346	2		RESISTOR 10 1% .125W F TC=0+-100	24546	C4-1/B-T0-10R0-F
A28R81	0757-0440	7		RESISTOR 7.5K 1% .125W F TC=0+-100	24546	C4-1/B-T0-7501-F
A28R82	0757-0405	4		RESISTOR 162 1% .125W F TC=0+-100	24546	C4-1/B-T0-162R-F
A28R83	0698-3162	0		RESISTOR 46.4K 1% .125W F TC=0+-100	24546	C4-1/B-T0-4642-F
A28R84	0698-0084	9		RESISTOR 2.15K 1% .125W F TC=0+-100	24546	C4-1/B-T0-2151-F
A28R85	2100-4004	8		RESISTOR-TRMR 10k 5% WW SID-ADJ 1-TRN	28480	2100-4004
A28R86	0698-6360	6		RESISTOR 10K .1% .125W F TC=0+-25	28480	0698-6360
A28R87	0698-6320	8		RESISTOR 5K .1% .125W F TC=0+-25	03868	PME55-1/B-T9-5001-B
A28R88	0698-6360	6		RESISTOR 10K .1% .125W F TC=0+-25	28480	0698-6360
A28R89	0698-3162	0		RESISTOR 46.4K 1% .125W F TC=0+-100	24546	C4-1/B-T0-4642-F
A28R90	0757-0346	2		RESISTOR 10 1% .125W F TC=0+-100	24546	C4-1/B-T0-10R0-F
A28R91	0757-0346	2		RESISTOR 10 1% .125W F TC=0+-100	24546	C4-1/B-T0-10R0-F
A28R92	0757-0280	3		RESISTOR 1K 1% .125W F TC=0+-100	24546	C4-1/B-T0-1001-F
A28R93	0698-3160	8	5	RESISTOR 31.6K 1% .125W F TC=0+-100	24546	C4-1/B-T0-3162-F
A28R94	0757-0442	9		RESISTOR 10K 1% .125W F TC=0+-100	24546	C4-1/B-T0-1002-F
A28R95	0698-3162	0		RESISTOR 46.4K 1% .125W F TC=0+-100	24546	C4-1/B-T0-4642-F
A28R96	0757-0280	3		RESISTOR 1K 1% .125W F TC=0+-100	24546	C4-1/B-T0-1001-F
A28R97	0757-0346	2		RESISTOR 10 1% .125W F TC=0+-100	24546	C4-1/B-T0-10R0-F
A28R98	0757-0346	2		RESISTOR 10 1% .125W F TC=0+-100	24546	C4-1/B-T0-10R0-F
A28R99	0757-0346	2		RESISTOR 10 1% .125W F TC=0+-100	24546	C4-1/B-T0-10R0-F
A28R100	0757-0280	3		RESISTOR 1K 1% .125W F TC=0+-100	24546	C4-1/B-T0-1001-F
A28R101	0698-3449	6	1	RESISTOR 28.7K 1% .125W F TC=0+-100	24546	C4-1/B-T0-2872-F
A28R102	0757-0346	2		RESISTOR 10 1% .125W F TC=0+-100	24546	C4-1/B-T0-10R0-F
A28R103	0698-3160	8		RESISTOR 31.6K 1% .125W F TC=0+-100	24546	C4-1/B-T0-3162-F
A28R104	0698-3160	8		RESISTOR 31.6K 1% .125W F TC=0+-100	24546	C4-1/B-T0-3162-F
A28R105	0757-0346	2		RESISTOR 10 1% .125W F TC=0+-100	24546	C4-1/B-T0-10R0-F
A28R106	0698-3159	5	2	RESISTOR 26.1K 1% .125W F TC=0+-100	24546	C4-1/B-T0-2612-F
A28R107	0698-3160	8		RESISTOR 31.6K 1% .125W F TC=0+-100	24546	C4-1/B-T0-3162-F
A28R108	0757-0280	3		RESISTOR 1K 1% .125W F TC=0+-100	24546	C4-1/B-T0-1001-F
A28R109	0757-0438	3		RESISTOR 5.11K 1% .125W F TC=0+-100	24546	C4-1/B-T0-5111-F
A28R110	0698-3153	9		RESISTOR 3.83K 1% .125W F TC=0+-100	24546	C4-1/B-T0-3831-F
A28R111	0757-0458	7	1	RESISTOR 51.1K 1% .125W F TC=0+-100	24546	C4-1/B-T0-5112-F
A28R112	0757-0280	3		RESISTOR 1K 1% .125W F TC=0+-100	24546	C4-1/B-T0-1001-F
A28R113	2100-4004	8		RESISTOR-TRMR 10K 5% WW SIDE-ADJ 1-TRN	28480	2100-4004
A28R114	0757-0442	9		RESISTOR 10K 1% .125W F TC=0+-100	24546	C4-1/B-T0-1002-F
A28R115	0698-3156	2		RESISTOR 14.7K 1% .125W F TC=0+-100	24546	C4-1/B-T0-1472-F
A28R116	0757-0443	0	1	RESISTOR 11K 1% .125W F TC=0+-100	24546	C4-1/B-T0-1102-F
A28R117	0698-3156	2		RESISTOR 14.7K 1% .125W F TC=0+-100	24546	C4-1/B-T0-1472-F
A28R118-122	0757-0346	2		RESISTOR 10 1% .125W F TC=0+-100	24546	C4-1/B-T0-10R0-F
A28R123	0698-0085	0	1	RESISTOR 2.61K 1% .125W F TC=0+-100	03292	CT4-1/B-T0-2611-F
A28R124, 125	0757-0346	2		RESISTOR 10 1% .125W F TC=0+-100	24546	C4-1/B-T0-10R0-F
A28R126	0757-0465	6		RESISTOR 100K 1% .125W F TC=0+-100	24546	C4-1/B-T0-1003-F
A28R127	0757-0442	9		RESISTOR 10K 1% .125W F TC=0+-100	24546	C4-1/B-T0-1002-F
A28R128	0757-0290	5	1	RESISTOR 6.19K 1% .125W F TC=0+-100	02995	5033R-1/B-T0-6191-F
A28R129	0757-0465	6	2	RESISTOR 100K 1% .125W F TC=0+-100	03292	CT4-1/B-T0-1003-F
A28R130	0698-3157	3		RESISTOR 19.6K 1% .125W F TC=0+-100	24546	C4-1/B-T0-1962-F
A28R131	0757-0439	4		RESISTOR 6.81K 1% .125W F TC=0+-100	24546	C4-1/B-T0-6811-F
A28R132	0698-3160	8		RESISTOR 31.6K 1% .125W F TC=0+-100	24546	C4-1/B-T0-3162-F
A28R133	0698-3159	5		RESISTOR 26.1K 1% .125W F TC=0+-100	24546	C4-1/B-T0-2612-F
A28R134	0698-4037	0	1	RESISTOR 46.4 1% .125W F TC=0+-100	03292	LO4D
A28R135	0757-0346	2		RESISTOR 10 1% .125W F TC=0+-100	24546	C4-1/B-T0-10R0-F
A28TP1	0360-0535	0	5	TERMINAL TEST POINT PCB	00000	ORDER BY DESCRIPTION
A28TP2	0360-0535	0		TERMINAL TEST POINT PCB	00000	ORDER BY DESCRIPTION
A28TP3	0360-0535	0		TERMINAL TEST POINT PCB	00000	ORDER BY DESCRIPTION
A28TP4	0360-0535	0		TERMINAL TEST POINT PCB	00000	ORDER BY DESCRIPTION
A28TP5	0360-0535	0		TERMINAL TEST POINT PCB	00000	ORDER BY DESCRIPTION
A28U1	1826-0471	2	5	IC OP AMP LOW-DRIFT TO-99 PKG	28480	1826-0471
A28U2	1826-0616	7	1	IC OP AMP PRON QUAD 14-DIP-C PKG	06665	OP-11EY
A28U3	1820-1934	2	2	IC CONV B-B-D/A 16-DIP-C PKG	06665	DAC-08EQ
A28U4	1820-1934	2		IC CONV B-B-D/A 16-DIP-C PKG	06665	DAC-08EQ
A28U5	1826-0785	1	1	IC OP AMP LOW-BIAS-H-IMPED DUAL B-DIP-C	01295	TL072ACJG
A28U6	1826-0471	2		IC OP AMP LOW-DRIFT TO-99 PKG	28480	1826-0471
A28U7	1826-0026	3	2	IC COMPARATOR PRON TO-99 PKG	01295	LM311L
A28U8	1826-0471	2		IC OP AMP LOW-DRIFT TO-99 PKG	28480	1826-0471
A28U9	1826-0853	4	1		28480	1826-0853
A28U10	1826-0471	2		IC OP AMP LOW-DRIFT TO-99 PKG	28480	1826-0471

See Introduction to this section for end-user information.

*Indicates factory selected value.

Table 6-3. Replaceable Parts

Reference Designation	HP Part Number	C D	Qty	Description	Mfr Code	Mfr Part Number
A2BU11	1826-0512	2	1	IC 78M15C V RGLTR TO-39	04713	MC78M15CG
A2BU12	1820-1203	8	1	IC GATE TTL LS AND TPL 3-INP	01295	SN74LS11N
A2BU13	1820-2056	1	1	IC FF TTL LS D-TYPE POS-EDGE-TRIG COM	01295	SN74LS378N
A2BU14	1820-1997	7	2	IC FF TTL LS D-TYPE POS-EDGE-TRIG PRL-IN	01295	SN74LS374N
A2BU15	1820-1997	7	1	IC FF TTL LS D-TYPE POS-EDGE-TRIG PRL-IN	01295	SN74LS374N
A2BU16	1820-1216	3	1	IC DCDR TTL LS 3-TO-8-LINE 3-INP	01295	SN74LS138N
A2BU17	1826-0759	9	3	IC COMPARATOR GP QUAD 14-DIP-C PKG	04713	LM339J
A2BU18	1826-0759	9	1	IC COMPARATOR GP QUAD 14-DIP-C PKG	04713	LM339J
A2BU19	1826-0759	9	1	IC COMPARATOR GP QUAD 14-DIP-C PKG	04713	LM339J
A2BU20	1810-0395	6	1	NETWORK-RES 8-SIP47.0K OHM X 7	11236	750-81-R47K
A2BU21	1810-0535	6	1	NETWORK-RES 16-DIP2.5K OHM X 8	28480	1810-0535
A2BU22	1826-0471	2	1	IC OP AMP LOW-DRIFT TO-99 PKG	28480	1826-0471
A2BU23	1826-0026	3	1	IC COMPARATOR PRCN TO-99 PKG	01295	LM311L
A2BVR1	1902-3171	7	1	DIODE-ZNR 11V 5% DO-35 PD=4W TC=+.062%	28480	1902-3171
A2BVR2	1902-0175	5	1	DIODE-ZNR 100V 5% PD=1W IR=5UA	28480	1902-0175
A2BW1	1460-1489	B	2	WIREFORM BE CU AG	28480	1460-1489
A2BW2	1460-1489	B	1	WIREFORM BE CU AG	28480	1460-1489

See introduction to this section for ordering information.

*Indicates factory stocked value.

Table 6-3. Replaceable Parts

Reference Designation	HP Part Number	C D	Qty	Description	Mfr Code	Mfr Part Number
A29	0B340-60034	9	1	REFERENCE PHASE DETECTOR	2B480	0B340-60034
A29C1	0160-2141	6	2	CAPACITOR-FXD 3.3UF+-10% 50VDC TA	04200	150D335X9050B2
A29C2	0160-0197	8	5	CAPACITOR-FXD 2.2UF+-10% 20VDC TA	56289	150D225X9020A2
A29C3	0160-1746	5	4	CAPACITOR-FXD 15UF+-10% 20VDC TA	56289	150D156X9020B2
A29C4	0160-3879	7	6	CAPACITOR-FXD .01UF +-20% 100VDC CER	2B480	0160-3879
A29C5	0140-0190	7	1	CAPACITOR-FXD 39PF +-5% 300VDC MICA	72136	DM15E390J0300WV1CR
A29C6	0160-3879	7		CAPACITOR-FXD .01UF +-20% 100VDC CER	2B480	0160-3879
A29C7	0160-2055	9	24	CAPACITOR-FXD .01UF +-20% 100VDC CER	2B480	0160-2055
A29C8	0160-2141	6		CAPACITOR-FXD 3.3UF+-10% 50VDC TA	04200	150D335X9050B2
A29C9	0160-3879	7		CAPACITOR-FXD .01UF +-20% 100VDC CER	2B480	0160-3879
A29C10	0160-2055	9		CAPACITOR-FXD .01UF +-20% 100VDC CER	2B480	0160-2055
A29C11	0160-0197	8		CAPACITOR-FXD 2.2UF+-10% 20VDC TA	56289	150D225X9020A2
A29C12	0160-2199	2	1	CAPACITOR-FXD 30PF +-5% 300VDC MICA	2B480	0160-2199
A29C13	0160-0197	8		CAPACITOR-FXD 2.2UF+-10% 20VDC TA	56289	150D225X9020A2
A29C14	0160-2204	0	3	CAPACITOR-FXD 100PF +-5% 300VDC MICA	2B480	0160-2204
A29C15	0160-0197	8		CAPACITOR-FXD 2.2UF+-10% 20VDC TA	56289	150D225X9020A2
A29C16	0160-2055	9		CAPACITOR-FXD .01UF +-20% 100VDC CER	2B480	0160-2055
A29C17	0160-2055	9		CAPACITOR-FXD .01UF +-20% 100VDC CER	2B480	0160-2055
A29C18	0160-2055	9		CAPACITOR-FXD .01UF +-20% 100VDC CER	2B480	0160-2055
A29C19	0160-2055	9		CAPACITOR-FXD .01UF +-20% 100VDC CER	2B480	0160-2055
A29C20	0160-2055	9		CAPACITOR-FXD .01UF +-20% 100VDC CER	2B480	0160-2055
A29C21	0160-2055	9		CAPACITOR-FXD .01UF +-20% 100VDC CER	2B480	0160-2055
A29C22	0160-2055	9		CAPACITOR-FXD .01UF +-20% 100VDC CER	2B480	0160-2055
A29C23	0160-0553	0	2	CAPACITOR-FXD 22UF+-20% 25VDC TA	2B480	0160-0553
A29C24	0160-2055	9		CAPACITOR-FXD .01UF +-20% 100VDC CER	2B480	0160-2055
A29C25	0160-2055	9		CAPACITOR-FXD .01UF +-20% 100VDC CER	2B480	0160-2055
A29C26	0160-2204	0		CAPACITOR-FXD 100PF +-5% 300VDC MICA	2B480	0160-2204
A29C27	0140-0193	0	4	CAPACITOR-FXD B2PF +-5% 300VDC MICA	72136	DM15EB20J0300WV1CR
A29C28	0160-0553	0		CAPACITOR-FXD 22UF+-20% 25VDC TA	2B480	0160-0553
A29C29	0160-2055	9		CAPACITOR-FXD .01UF +-20% 100VDC CER	2B480	0160-2055
A29C30	0140-0193	0		CAPACITOR-FXD B2PF +-5% 300VDC MICA	72136	DM15EB20J0300WV1CR
A29C31	0160-1746	5		CAPACITOR-FXD 15UF+-10% 20VDC TA	56289	150D156X9020B2
A29C32	0170-0066	9	1	CAPACITOR-FXD .027UF +-10% 200VDC POLYE	2B480	0170-0066
A29C33	0160-2055	9		CAPACITOR-FXD .01UF +-20% 100VDC CER	2B480	0160-2055
A29C34	0160-2055	9		CAPACITOR-FXD .01UF +-20% 100VDC CER	2B480	0160-2055
A29C35	0140-0193	0		CAPACITOR-FXD B2PF +-5% 300VDC MICA	72136	DM15EB20J0300WV1CR
A29C36	0160-2055	9		CAPACITOR-FXD .01UF +-20% 100VDC CER	2B480	0160-2055
A29C37	0160-2055	9		CAPACITOR-FXD .01UF +-20% 100VDC CER	2B480	0160-2055
A29C38	0140-0193	0		CAPACITOR-FXD B2PF +-5% 300VDC MICA	72136	DM15EB20J0300WV1CR
A29C39	0160-3879	7		CAPACITOR-FXD .01UF +-20% 100VDC CER	2B480	0160-3879
A29C40	0160-1746	5		CAPACITOR-FXD 15UF+-10% 20VDC TA	56289	150D156X9020B2
A29C41	0160-2055	9		CAPACITOR-FXD .01UF +-20% 100VDC CER	2B480	0160-2055
A29C42	0160-2055	9		CAPACITOR-FXD .01UF +-20% 100VDC CER	2B480	0160-2055
A29C43	0160-2206	2	1	CAPACITOR-FXD 160PF +-5% 300VDC MICA	2B480	0160-2206
A29C44	0160-2055	9		CAPACITOR-FXD .01UF +-20% 100VDC CER	2B480	0160-2055
A29C45	0160-2055	9		CAPACITOR-FXD .01UF +-20% 100VDC CER	2B480	0160-2055
A29C46	0140-0210	2	3	CAPACITOR-FXD 270PF +-5% 300VDC MICA	72136	DM15F271J0300WV1CR
A29C47	0160-2055	9		CAPACITOR-FXD .01UF +-20% 100VDC CER	2B480	0160-2055
A29C48	0140-0210	2		CAPACITOR-FXD 270PF +-5% 300VDC MICA	72136	DM15F271J0300WV1CR
A29C49	0160-2201	7	1	CAPACITOR-FXD 51PF +-5% 300VDC MICA	2B480	0160-2201
A29C50	0160-2055	9		CAPACITOR-FXD .01UF +-20% 100VDC CER	2B480	0160-2055
A29C51	0140-0210	2		CAPACITOR-FXD 270PF +-5% 300VDC MICA	72136	DM15F271J0300WV1CR
A29C52	0160-2055	9		CAPACITOR-FXD .01UF +-20% 100VDC CER	2B480	0160-2055
A29C53	0160-2055	9		CAPACITOR-FXD .01UF +-20% 100VDC CER	2B480	0160-2055
A29C54	0160-0163	2	1	CAPACITOR-FXD 10UF+75-10% 50VDC AL	56289	30D106G050CB2
A29C55	0160-1746	5		CAPACITOR-FXD 15UF+-10% 20VDC TA	56289	150D156X9020B2
A29C56	0160-0229	7	1	CAPACITOR-FXD 33UF+-10% 10VDC TA	56289	150D336X9010B2
A29C57	0160-2204	0		CAPACITOR-FXD 100PF +-5% 300VDC MICA	2B480	0160-2204
A29C58	0160-3879	7		CAPACITOR-FXD .01UF +-20% 100VDC CER	2B480	0160-3879
A29C59	0160-3878	6	2	CAPACITOR-FXD 1000PF +-20% 100VDC CER	2B480	0160-3878
A29C60	0160-3879	7		CAPACITOR-FXD .01UF +-20% 100VDC CER	2B480	0160-3879
A29C61	0160-3454	4	1	CAPACITOR-FXD 220PF +-10% 1KVDC CER	2B480	0160-3454
A29C62	0160-3878	6		CAPACITOR-FXD 1000PF +-20% 100VDC CER	2B480	0160-3878
A29CR1	1901-0518	8	6	DIODE-SM SIG SCHOTTKY	2B480	1901-0518
A29CR2	1901-0518	8		DIODE-SM SIG SCHOTTKY	2B480	1901-0518
A29CR3	1901-0518	8		DIODE-SM SIG SCHOTTKY	2B480	1901-0518
A29CR4	1901-0518	8		DIODE-SM SIG SCHOTTKY	2B480	1901-0518
A29CR5	1901-0518	8		DIODE-SM SIG SCHOTTKY	2B480	1901-0518
A29CR6	1901-0518	8		DIODE-SM SIG SCHOTTKY	2B480	1901-0518
A29J1	1250-0544	9	5	CONNECTOR- RF MALE SMB	2B480	1250-0544
A29J2	1250-0544	9		CONNECTOR- RF MALE SMB	2B480	1250-0544
A29J3	1250-0544	9		CONNECTOR- RF MALE SMB	2B480	1250-0544

See Introduction to this section for ordering information.

*Indicates factory selected value.

Table 6-3. Model 8340A Replaceable Parts

Reference Designation	HP Part Number	C D	Qty	Description	Mfr Code	Mfr Part Number
A29J4	1250-0544	9		CONNECTOR- RF MALE SMB	28480	1250-0544
A29J5	1250-0544	9		CONNECTOR- RF MALE SMB	28480	1250-0544
A29L1	9140-0238	3	2	INDUCTOR RF-CH-MLD 82UH 5% .166DX.385LG	28480	9140-0238
A29L2	9140-0238	3		INDUCTOR RF-CH-MLD 82UH 5% .166DX.385LG	28480	9140-0238
A29L3	9140-0143	9	2	INDUCTOR RF-CH-MLD 3.3UH 10% .105DX.26LG	28480	9140-0143
A29L4	9140-0143	9		INDUCTOR RF-CH-MLD 3.3UH 10% .105DX.26LG	28480	9140-0143
A29L5	9100-2261	2	1	INDUCTOR RF-CH-MLD 2.7UH 10% .105DX.26LG	28480	9100-2261
A29L6	9140-0114	4	1	INDUCTOR RF-CH-MLD 10UH 10% .166DX.385LG	28480	9140-0114
A29L7	9100-2255	4	4	INDUCTOR RF-CH-MLD 470NH 10% .105DX.26LG	28480	9100-2255
A29L8	9100-0368	6	1	INDUCTOR RF-CH-MLD 330NH 10% .105DX.26LG	28480	9100-0368
A29L9	9100-2257	6	3	INDUCTOR RF-CH-MLD 820NH 10% .105DX.26LG	28480	9100-2257
A29L10	9100-2255	4		INDUCTOR RF-CH-MLD 470NH 10% .105DX.26LG	28480	9100-2255
A29L11	9100-2257	6		INDUCTOR RF-CH-MLD 820NH 10% .105DX.26LG	28480	9100-2257
A29L12	9100-2255	4		INDUCTOR RF-CH-MLD 470NH 10% .105DX.26LG	28480	9100-2255
A29L13	9100-2257	6		INDUCTOR RF-CH-MLD 820NH 10% .105DX.26LG	28480	9100-2257
A29L14	9100-2255	4		INDUCTOR RF-CH-MLD 470NH 10% .105DX.26LG	28480	9100-2255
A29L15	9100-2256	5	1	INDUCTOR RF-CH-MLD 560NH 10% .105DX.26LG	28480	9100-2256
A29L16	9100-2891	4	1	INDUCTOR RF-CH-MLD 50NH 10% .105DX.26LG	28480	9100-2891
A29MP1	1205-0250	9	1	THERMISTOR LINK T0-5/T0-39	28480	1205-0250
A29MP2	2190-0124	4	1	WASHER-LK INTL T NO. 10 .195-IN-ID	28480	2190-0124
A29MP3	2200-0101	0	3	SCREW-MACH 4-40 .188-IN-LG PAN-HD-POZI	00000	ORDER BY DESCRIPTION
A29MP4	2200-0101	0		SCREW-MACH 4-40 .188-IN-LG PAN-HD-POZI	00000	ORDER BY DESCRIPTION
A29MP5	2200-0101	0		SCREW-MACH 4-40 .188-IN-LG PAN-HD-POZI	00000	ORDER BY DESCRIPTION
A29MP6	2950-0078	9	1	NUT-HEX-DBL-CHAM 10-32-THD .067-IN-THK	28480	2950-0078
A29MP7	08340-20090	3	1	COVER-PC REF. PHASE DETECTOR	28480	08340-20090
A29MP8	86701-40001	9	2	EXTRACTOR-PC BOARD	28480	86701-40001
A29MP9	86701-40001	9		EXTRACTOR-PC BOARD	28480	86701-40001
A29Q1	1854-0019	3	3	TRANSISTOR NPN SI T0-18 PD=360MW	28480	1854-0019
A29Q2	1854-0019	3		TRANSISTOR NPN SI T0-18 PD=360MW	28480	1854-0019
A29Q3	1854-0019	3		TRANSISTOR NPN SI T0-18 PD=360MW	28480	1854-0019
A29Q4	1855-0049	1	1	TRANSISTOR-JFET DUAL N-CHAN D-MODE SI	28480	1855-0049
A29Q5	1853-0451	5	2	TRANSISTOR PNP 2N3799 SI T0-18 PD=360MW	01295	2N3799
A29Q6	1853-0451	5		TRANSISTOR PNP 2N3799 SI T0-18 PD=360MW	01295	2N3799
A29Q7	1853-0034	0	1	TRANSISTOR PNP SI T0-18 PD=360MW	28480	1853-0034
A29R1	0757-0399	5	2	RESISTOR 82.5 1% .125W F TC=0+100	24546	C4-1/8-T0-82R5-F
A29R2	0757-0417	8	1	RESISTOR 562 1% .125W F TC=0+100	24546	C4-1/8-T0-562R-F
A29R3	0757-0416	7	4	RESISTOR 511 1% .125W F TC=0+100	24546	C4-1/8-T0-511R-F
A29R4	0757-0401	0	3	RESISTOR 100 1% .125W F TC=0+100	24546	C4-1/8-T0-101R-F
A29R5	0698-3156	2	1	RESISTOR 14.7K 1% .125W F TC=0+100	24546	C4-1/8-T0-1472-F
A29R6	0757-0401	0		RESISTOR 100 1% .125W F TC=0+100	24546	C4-1/8-T0-101R-F
A29R7	0757-0420	3	1	RESISTOR 750 1% .125W F TC=0+100	24546	C4-1/8-T0-751R-F
A29R8	0757-0438	3	1	RESISTOR 5.11K 1% .125W F TC=0+100	24546	C4-1/8-T0-5111R-F
A29R9	0757-0399	5	3	RESISTOR 82.5 1% .125W F TC=0+100	24546	C4-1/8-T0-82R5-F
A29R10	0698-7222	1	1	RESISTOR 261 1% .05W F TC=0+100	24546	C3-1/8-T0-261R-F
A29R11	0698-7219	6	1	RESISTOR 196 1% .05W F TC=0+100	24546	C3-1/8-T0-196R-F
A29R12	0757-0442	9	5	RESISTOR 10K 1% .125W F TC=0+100	24546	C4-1/8-T0-1002-F
A29R13	0698-3453	2	3	RESISTOR 196K 1% .125W F TC=0+100	24546	C4-1/8-T0-1963-F
A29R14	0757-0442	9	2	RESISTOR 10K 1% .125W F TC=0+100	24546	C4-1/8-T0-1002-F
A29R15	0698-3453	2		RESISTOR 196K 1% .125W F TC=0+100	24546	C4-1/8-T0-1963-F
A29R16	0757-0441	8	2	RESISTOR 8.25K 1% .125W F TC=0+100	24546	C4-1/8-T0-8251-F
A29R17	0698-3438	3	2	RESISTOR 147 1% .125W F TC=0+100	24546	C4-1/8-T0-147R-F
A29R18	0757-0346	2	6	RESISTOR 10 1% .125W F TC=0+100	24546	C4-1/8-T0-10R0-F
A29R19	0757-0346	2		RESISTOR 10 1% .125W F TC=0+100	24546	C4-1/8-T0-10R0-F
A29R20	0757-0441	8		RESISTOR 8.25K 1% .125W F TC=0+100	24546	C4-1/8-T0-8251-F
A29R21	0698-3438	3		RESISTOR 147 1% .125W F TC=0+100	24546	C4-1/8-T0-147R-F
A29R22	0698-3136	8	1	RESISTOR 17.8K 1% .125W F TC=0+100	24546	C4-1/8-T0-1782-F
A29R23	0757-0346	2		RESISTOR 10 1% .125W F TC=0+100	24546	C4-1/8-T0-10R0-F
A29R24	0698-3154	0	5	RESISTOR 4.22K 1% .125W F TC=0+100	24546	C4-1/8-T0-4221-F
A29R25	0757-0346	2		RESISTOR 10 1% .125W F TC=0+100	24546	C4-1/8-T0-10R0-F
A29R26	0757-0280	3	5	RESISTOR 1K 1% .125W F TC=0+100	24546	C4-1/8-T0-1001-F
A29R27	0698-3154	0		RESISTOR 4.22K 1% .125W F TC=0+100	24546	C4-1/8-T0-4221-F
A29R28	0698-3450	9	1	RESISTOR 42.2K 1% .125W F TC=0+100	24546	C4-1/8-T0-4222-F
A29R29	0698-3449	6	1	RESISTOR 28.7K 1% .125W F TC=0+100	24546	C4-1/8-T0-2872-F
A29R30	0757-0444	1	2	RESISTOR 12.1K 1% .125W F TC=0+100	24546	C4-1/8-T0-1212-F
A29R31	0698-3154	0		RESISTOR 4.22K 1% .125W F TC=0+100	24546	C4-1/8-T0-4221-F
A29R32	0757-0346	2		RESISTOR 10 1% .125W F TC=0+100	24546	C4-1/8-T0-10R0-F
A29R33	0698-3154	0		RESISTOR 4.22K 1% .125W F TC=0+100	24546	C4-1/8-T0-4221-F
A29R34	0757-0346	2		RESISTOR 10 1% .125W F TC=0+100	24546	C4-1/8-T0-10R0-F
A29R35	0757-0280	3		RESISTOR 1K 1% .125W F TC=0+100	24546	C4-1/8-T0-1001-F
A29R36	0757-0444	1		RESISTOR 12.1K 1% .125W F TC=0+100	24546	C4-1/8-T0-1212-F
A29R37	0757-0200	7	1	RESISTOR 5.62K 1% .125W F TC=0+100	24546	C4-1/8-T0-5621-F
A29R38	0757-0421	4	2	RESISTOR 825 1% .125W F TC=0+100	24546	C4-1/8-T0-825R-F
A29R39	0757-0440	7	1	RESISTOR 7.5K 1% .125W F TC=0+100	24546	C4-1/8-T0-7501-F

See introduction to this section for ordering information
 *Indicates factory selected value

Table 6-3. Model 8340A Replaceable Parts

Reference Designation	HP Part Number	C D	Qty	Description	Mfr Code	Mfr Part Number
A29R40	0757-0394	0	2	RESISTOR 51.1 1% .125W F TC=0+100	24546	C4-1/8-T0-51R1-F
A29R41	0698-3446	3	2	RESISTOR 383 1% .125W F TC=0+100	24546	C4-1/8-T0-383R-F
A29R42	0698-0085	0	3	RESISTOR 2.61K 1% .125W F TC=0+100	24546	C4-1/8-T0-2611-F
A29R43	0757-0442	9		RESISTOR 10K 1% .125W F TC=0+100	24546	C4-1/8-T0-1002-F
A29R44	0757-0442	9		RESISTOR 10K 1% .125W F TC=0+100	24546	C4-1/8-T0-1002-F
A29R45	0757-0280	3		RESISTOR 1K 1% .125W F TC=0+100	24546	C4-1/8-T0-1001-F
A29R46	0698-3154	0		RESISTOR 4.22K 1% .125W F TC=0+100	24546	C4-1/8-T0-4221-F
A29R47	0698-3453	2		RESISTOR 196K 1% .125W F TC=0+100	24546	C4-1/8-T0-1963-F
A29R48	0757-0442	9		RESISTOR 10K 1% .125W F TC=0+100	24546	C4-1/8-T0-1002-F
A29R49	0698-7285	6	1	RESISTOR 110K 1% .05W F TC=0+100	24546	C3-1/8-T0-1103-F
A29R50	0698-3157	3	2	RESISTOR 19.6K 1% .125W F TC=0+100	24546	C4-1/8-T0-1962-F
A29R51	0698-3157	3		RESISTOR 19.6K 1% .125W F TC=0+100	24546	C4-1/8-T0-1962-F
A29R52	0757-0401	0		RESISTOR 100 1% .125W F TC=0+100	24546	C4-1/8-T0-1001-F
A29R53	0698-3440	7	2	RESISTOR 196 1% .125W F TC=0+100	24546	C4-1/8-T0-196R-F
A29R54	0698-7234	5	1	RESISTOR 825 1% .05W F TC=0+100	24546	C4-1/8-T0-825R-F
A29R55	0698-7257	2	1	RESISTOR 7.5K 1% .05W F TC=0+100	24546	C3-1/8-T0-7501-F
A29R56	0757-0394	0		RESISTOR 51.1 1% .125W F TC=0+100	24546	C4-1/8-T0-51R1-F
A29R57	0698-3446	3		RESISTOR 383 1% .125W F TC=0+100	24546	C4-1/8-T0-383R-F
A29R58	0698-7246	9	1	RESISTOR 2.61K 1% .05W F TC=0+100	24546	C3-1/8-T0-2611-F
A29R59	0698-3440	7		RESISTOR 196 1% .125W F TC=0+100	24546	C4-1/8-T0-196R-F
A29R60				NOT ASSIGNED		
A29R61	0757-0280	3		RESISTOR 1K 1% .125W F TC=0+100	24546	C4-1/8-T0-1001-F
A29R62	0757-0278	9	1	RESISTOR 1.78K 1% .125W F TC=0+100	24546	C4-1/8-T0-1781-F
A29R63	0698-0085	0		RESISTOR 2.61K 1% .125W F TC=0+100	24546	C4-1/8-T0-2611-F
A29R64	0698-3132	4	2	RESISTOR 261 1% .125W F TC=0+100	24546	C4-1/8-T0-2610-F
A29R65	0698-0085	0		RESISTOR 2.61K 1% .125W F TC=0+100	24546	C4-1/8-T0-2611-F
A29R66	0757-0421	4		RESISTOR 825 1% .125W F TC=0+100	24546	C4-1/8-T0-825R-F
A29R67	0757-0280	3		RESISTOR 1K 1% .125W F TC=0+100	24546	C4-1/8-T0-1001-F
A29R68	0757-0416	7		RESISTOR 511 1% .125W F TC=0+100	24546	C4-1/8-T0-511R-F
A29R69	0757-0416	7		RESISTOR 511 1% .125W F TC=0+100	24546	C4-1/8-T0-511R-F
A29R70	0757-0416	7		RESISTOR 511 1% .125W F TC=0+100	24546	C4-1/8-T0-511R-F
A29R71	0757-0274	5	1	RESISTOR 1.21K 1% .125W F TC=0+100	24546	C4-1/8-T0-1211-F
A29R72	0698-3132	4		RESISTOR 261 1% .125W F TC=0+100	24546	C4-1/8-T0-2610-F
A29R73	0757-0317	7	1	RESISTOR 1.33K 1% .125W F TC=0+100	24546	C4-1/8-T0-1331-F
A29R74	0757-0289	2	1	RESISTOR 13.3K 1% .125W F TC=0+100	19701	MF4C1/8-T0-1332-F
A29R75	0698-7236	7	1	RESISTOR 1K 1% .05W F TC=0+100	24546	C3-1/8-T0-1001-F
A29T1	08552-6044	1	2	TRANSFORMER-RF 5 PIN	28480	08552-6044
A29T2	08552-6044	1		TRANSFORMER-RF 5 PIN	28480	08552-6044
A29TP1	0360-0535	0	1	TERMINAL TEST POINT PCB	00000	ORDER BY DESCRIPTION
A29U1	1858-0032	8	1	TRANSISTOR ARRAY 14-PIN PLSTC DIP	3L585	CA3146E
A29U2	1820-0328	6	1	IC GATE TTL NOR QUAD 2-INP	01295	SN7402N
A29U3	1820-1383	5	1	IC CNTR ECL BCD POS-EDGE-TRIG	04713	MC10138L
A29U4	1820-0802	1	1	IC GATE ECL NOR QUAD 2-INP	04713	MC10102P
A29U5	1820-0223	0	1	IC OP AMP GP TO-99 PKG	3L585	CA301AT
A29U6	1820-0429	8	1	IC V RGLTR TO-39	18324	LM309H
A29VR1	1902-3082	9	1	DIODE-ZNR 4.64V 5% DO-35 PD=.4W	28480	1902-3082
A29VR2	1902-3256	9	1	DIODE-ZNR 23.7V 5% DO-35 PD=.4W	28480	1902-3256
A29W1	08340-60101	1	1	CABLE ASSEMBLY- A29	28480	08340-60101

See introduction to this section for ordering information
 *Indicates factory selected value

Table 6-3. Model 8340A Replaceable Parts

Reference Designation	HP Part Number	C D	Qty	Description	Mfr Code	Mfr Part Number
A30	08340-60035	0	1	100 MHZ VCXO	28480	08340-60035
A30C1	0121-0495	5	3	CAPACITOR-V TRMR-AIR 1.9-15.7PF 175V	74970	187-0309-125
A30C2	0121-0495	5		CAPACITOR-V TRMR-AIR 1.9-15.7PF 175V	74970	187-0309-125
A30C3	0121-0495	5		CAPACITOR-V TRMR-AIR 1.9-15.7PF 175V	74970	187-0309-125
A30C4	0121-0493	3	1	CAPACITOR-V TRMR-AIR 1.7-11PF 175V	74970	187-0306-125
A30C5	0180-0049	9	1	CAPACITOR-FXD 20UF+75-10% 50VDC AL	56289	30D206G050CC2
A30C6	0160-3456	6	5	CAPACITOR-FXD 1000PF +10% 1KVDC CER	28480	0160-3456
A30C7	0160-3454	4	19	CAPACITOR-FXD 220PF +10% 1KVDC CER	28480	0160-3454
A30C8*	0160-2253	9	1	CAPACITOR-FXD 6.8PF +.5PF 100VDC CER	28480	0160-2253
A30C9	0160-4084	8	1	CAPACITOR-FXD .1UF +20% 50VDC CER	28480	0160-4084
A30C10	0140-0191	8	1	CAPACITOR-FXD 56PF +5% 300VDC MICA	72136	DML5E560J0300WV1CR
A30C11	0160-2204	0	1	CAPACITOR-FXD 100PF +5% 300VDC MICA	28480	0160-2204
A30C12	0160-3454	4		CAPACITOR-FXD 220PF +10% 1KVDC CER	28480	0160-3454
A30C13	0160-3454	4		CAPACITOR-FXD 220PF +10% 1KVDC CER	28480	0160-3454
A30C14	0160-3454	4		CAPACITOR-FXD 220PF +10% 1KVDC CER	28480	0160-3454
A30C15	0160-2261	9	8	CAPACITOR-FXD 15PF +5% 500VDC CER 0+30	28480	0160-2261
A30C16	0160-2261	9		CAPACITOR-FXD 15PF +5% 500VDC CER 0+30	28480	0160-2261
A30C17	0160-3454	4		CAPACITOR-FXD 220PF +10% 1KVDC CER	28480	0160-3454
A30C18	0160-3454	4		CAPACITOR-FXD 220PF +10% 1KVDC CER	28480	0160-3454
A30C19	0160-2261	9		CAPACITOR-FXD 15PF +5% 500VDC CER 0+30	28480	0160-2261
A30C20	0160-2261	9		CAPACITOR-FXD 15PF +5% 500VDC CER 0+30	28480	0160-2261
A30C21	0160-3454	4		CAPACITOR-FXD 220PF +10% 1KVDC CER	28480	0160-3454
A30C22	0160-3454	4		CAPACITOR-FXD 220PF +10% 1KVDC CER	28480	0160-3454
A30C23	0160-3454	4		CAPACITOR-FXD 220PF +10% 1KVDC CER	28480	0160-3454
A30C24	0160-3454	4		CAPACITOR-FXD 220PF +10% 1KVDC CER	28480	0160-3454
A30C25	0160-3454	4		CAPACITOR-FXD 220PF +10% 1KVDC CER	28480	0160-3454
A30C26	0160-2261	9		CAPACITOR-FXD 15PF +5% 500VDC CER 0+30	28480	0160-2261
A30C27	0160-2261	9		CAPACITOR-FXD 15PF +5% 500VDC CER 0+30	28480	0160-2261
A30C28	0160-3872	0	2	CAPACITOR-FXD 2.2PF +.25PF 200VDC CER	28480	0160-3872
A30C29	0160-3872	0		CAPACITOR-FXD 2.2PF +.25PF 200VDC CER	28480	0160-3872
A30C30	0160-3454	4		CAPACITOR-FXD 220PF +10% 1KVDC CER	28480	0160-3454
A30C31	0160-3454	4		CAPACITOR-FXD 220PF +10% 1KVDC CER	28480	0160-3454
A30C32	0160-2261	9		CAPACITOR-FXD 15PF +5% 500VDC CER 0+30	28480	0160-2261
A30C33	0160-2261	9		CAPACITOR-FXD 15PF +5% 500VDC CER 0+30	28480	0160-2261
A30C34	0160-3454	4		CAPACITOR-FXD 220PF +10% 1KVDC CER	28480	0160-3454
A30C35	0160-3454	4		CAPACITOR-FXD 220PF +10% 1KVDC CER	28480	0160-3454
A30C36	0160-3878	6	7	CAPACITOR-FXD 1000PF +20% 100VDC CER	28480	0160-3878
A30C37	0160-3878	6		CAPACITOR-FXD 1000PF +20% 100VDC CER	28480	0160-3878
A30C38	0160-3878	6		CAPACITOR-FXD 1000PF +20% 100VDC CER	28480	0160-3878
A30C39	0160-3454	4		CAPACITOR-FXD 220PF +10% 1KVDC CER	28480	0160-3454
A30C40	0160-2238	0	1	CAPACITOR-FXD 1.5PF +.25PF 500VDC CER	28480	0160-2238
A30C41	0160-3878	6		CAPACITOR-FXD 1000PF +20% 100VDC CER	28480	0160-3878
A30C42	0160-3878	6		CAPACITOR-FXD 1000PF +20% 100VDC CER	28480	0160-3878
A30C43	0180-0116	1	2	CAPACITOR-FXD 6.8UF+10% 35VDC TA	56289	150D685X9035B2
A30C44	0160-2253	9	1	CAPACITOR-FXD 6.8PF +.25PF 500VDC CER	28480	0160-2253
A30C45	0160-3878	6		CAPACITOR-FXD 1000PF +20% 100VDC CER	28480	0160-3878
A30C46	0160-3878	6		CAPACITOR-FXD 1000PF +20% 100VDC CER	28480	0160-3878
A30C47	0160-3454	4		CAPACITOR-FXD 220PF +10% 1KVDC CER	28480	0160-3454
A30C48	0160-3456	6		CAPACITOR-FXD 1000PF +10% 1KVDC CER	28480	0160-3456
A30C49	0160-3456	6		CAPACITOR-FXD 1000PF +10% 1KVDC CER	28480	0160-3456
A30C50	0180-0116	1		CAPACITOR-FXD 6.8UF+10% 35VDC TA	56289	150D685X9035B2
A30C51	0160-4299	7	1	CAPACITOR-FXD 2200PF +20% 250VDC CER	56289	C067F251F222MS22-CDH
A30C52	0160-3456	6		CAPACITOR-FXD 1000PF +10% 1KVDC CER	28480	0160-3456
A30C53	0160-3456	6		CAPACITOR-FXD 1000PF +10% 1KVDC CER	28480	0160-3456
A30C54	0160-3454	4		CAPACITOR-FXD 220PF +10% 1KVDC CER	28480	0160-3454
A30C55	0160-3454	4		CAPACITOR-FXD 220PF +10% 1KVDC CER	28480	0160-3454
A30C56	0160-2437	1	1	CAPACITOR-FDTHRU 5000PF +80 -20% 200V	28480	0160-2437
A30CR1	0122-0245	5	1	DIODE-VVC 1N5139 6.8PF 10%	01281	1N5139
A30CR2				NOT ASSIGNED		
A30CR3	1901-0539	3	2	DIODE-SM SIG SCHOTTKY	28480	1901-0539
A30CR4	1901-0539	3		DIODE-SM SIG SCHOTTKY	28480	1901-0539
A30E1	9170-0029	3	1	CORE-SHIELDING BEAD	28480	9170-0029
A30J1	1250-0544	9	3	CONNECTOR-RF MALE SMB	28480	1250-0544
A30J2	1250-0544	9		CONNECTOR-RF MALE SMB	28480	1250-0544
A30J3	1250-0544	9		CONNECTOR-RF MALE SMB	28480	1250-0544
A30L1				NOT ASSIGNED		
A30L2	9100-2250	7	1	INDUCTOR RF-CH-MLD 180NH 10% .105DX.26LG	28480	9100-2250
A30L3	9140-0158	6	3	INDUCTOR RF-CH-MLD 1UH 10% .105DX.26LG	28480	9140-0158
A30L4*	9100-0368	6	1	INDUCTOR RF-CH-MLD 330NH 10% .105DX.26LG	28480	9100-0368
A30L5	9100-2538	6	1	INDUCTOR RF-CH-MLD 1UH 10% .161DX.385LG	28480	9100-2538
A30L6	9100-2251	0	4	INDUCTOR RF-CH-MLD 220NH 10% .105DX.26LG	28480	9100-2251
A30L7	9100-2251	0		INDUCTOR RF-CH-MLD 220NH 10% .105DX.26LG	28480	9100-2251

See introduction to this section for ordering information
 *Indicates factory selected value

Table 6-3. Model 8340A Replaceable Parts

Reference Designation	HP Part Number	C D	Qty	Description	Mfr Code	Mfr Part Number
A30L8	9100-2251	0		INDUCTOR RF-CH-MLD 220NH 10% .105DX.26LG	28480	9100-2251
A30L9	9100-2251	0		INDUCTOR RF-CH-MLD 220NH 10% .105DX.26LG	28480	9100-2251
A30L10-13				NOT ASSIGNED		
A30L14	9100-2247	4	2	INDUCTOR RF-CH-MLD 100NH 10% .105DX.26LG	28480	9100-2247
A30L15	9100-2247	4		INDUCTOR RF-CH-MLD 100NH 10% .105DX.26LG	28480	9100-2247
A30L16	9140-0158	6		INDUCTOR RF-CH-MLD 1UH 10% .105DX.26LG	28480	9140-0158
A30L17	9140-0158	6		INDUCTOR RF-CH-MLD 1UH 10% .105DX.26LG	28480	9140-0158
A30L18	9140-0144	0	2	INDUCTOR RF-CH-MLD 4.7UH 10% .105DX.26LG	28480	9140-0144
A30L19	9140-0144	0		INDUCTOR RF-CH-MLD 4.7UH 10% .105DX.26LG	28480	9140-0144
A30MP1				NOT ASSIGNED		
A30MP2				NOT ASSIGNED		
A30MP3	2190-0009	4	1	WASHER-LK INT'L T NO. 8 .168-IN-ID	28480	2190-0009
A30MP4	2190-0124	4	1	WASHER-LK INT'L T NO. 10 .195-IN-ID	28480	2190-0124
A30MP5	2200-0101	0	2	SCREW-MACH 4-40 .188-IN-LG PAN-HD-POZI	00000	ORDER BY DESCRIPTION
A30MP6	2200-0101	0		SCREW-MACH 4-40 .188-IN-LG PAN-HD-POZI	00000	ORDER BY DESCRIPTION
A30MP7	2200-0103	2	3	SCREW-MACH 4-40 .25-IN-LG PAN-HD-POZI	00000	ORDER BY DESCRIPTION
A30MP8	2200-0103	2		SCREW-MACH 4-40 .25-IN-LG PAN-HD-POZI	00000	ORDER BY DESCRIPTION
A30MP9	2200-0103	2		SCREW-MACH 4-40 .25-IN-LG PAN-HD-POZI	00000	ORDER BY DESCRIPTION
A30MP10	2580-0002	4	1	NUT-HEX-DBL-CHAM 8-32-THD .085-IN-THK	00000	ORDER BY DESCRIPTION
A30MP11	2950-0078	9	1	NUT-HEX-DBL-CHAM 10-32-THD .067-IN-THK	28480	2950-0078
A30MP12	4330-0145	9	1	INS. BEAD GL.062L	28480	4330-0145
A30MP13	08340-20091	4	1	COVER-PC VCXO	28480	08340-20091
A30MP14	86701-40001	9	2	EXTRACTOR-PC BOARD	28480	86701-40001
A30MP15	86701-40001	9		EXTRACTOR-PC BOARD	28480	86701-40001
A30MP16	86701-00045	7	1	SHIELD	28480	86701-00045
A30MP17	0460-0683	1	1	TAPE-FILM 1.5	28480	0460-0683
A30MP18	0460-1303	4	1	TAPE-SILICON SPONGE	28480	0460-1303
A30MP19	6960-0059	1	1	PLUG-HOLE RND-HD FOR .187-D-HOLE NYL	28480	6960-0059
A30Q1	1854-0345	8	9	TRANSISTOR NPN 2N5179 SI TO-72 PD=200MW	04713	2N5179
A30Q2	1854-0345	8		TRANSISTOR NPN 2N5179 SI TO-72 PD=200MW	04713	2N5179
A30Q3	1854-0345	8		TRANSISTOR NPN 2N5179 SI TO-72 PD=200MW	04713	2N5179
A30Q4	1854-0345	8		TRANSISTOR NPN 2N5179 SI TO-72 PD=200MW	04713	2N5179
A30Q5	1854-0247	9	1	TRANSISTOR NPN SI TO-39 PD=1W FT=800MHZ	28480	1854-0247
A30Q6	1854-0345	8		TRANSISTOR NPN 2N5179 SI TO-72 PD=200MW	04713	2N5179
A30Q7	1854-0345	8		TRANSISTOR NPN 2N5179 SI TO-72 PD=200MW	04713	2N5179
A30Q8	1854-0345	8		TRANSISTOR NPN 2N5179 SI TO-72 PD=200MW	04713	2N5179
A30Q9	1854-0345	8		TRANSISTOR NPN 2N5179 SI TO-72 PD=200MW	04713	2N5179
A30Q10	1854-0404	0	1	TRANSISTOR NPN SI TO-18 PD=360MW	28480	1854-0404
A30Q11	1854-0345	8		TRANSISTOR NPN 2N5179 SI TO-72 PD=200MW	04713	2N5179
A30R1	0757-0279	0	3	RESISTOR 3.16K 1% .125W F TC=0+100	24546	C4-1/8-T0-3161-F
A30R2	0757-0419	0	1	RESISTOR 681 1% .125W F TC=0+100	24546	C4-1/8-T0-681R-F
A30R3	0698-3440	7	1	RESISTOR 196 1% .125W F TC=0+100	24546	C4-1/8-T0-196R-F
A30R4	0757-0422	5	6	RESISTOR 909 1% .125W F TC=0+100	24546	C4-1/8-T0-909R-F
A30R5	0698-3155	1	2	RESISTOR 4.64K 1% .125W F TC=0+100	24546	C4-1/8-T0-4641-F
A30R6	0698-7224	3	1	RESISTOR 316 1% .05W F TC=0+100	24546	C3-1/8-T0-316R-F
A30R7	0757-0346	2	2	RESISTOR 10 1% .125W F TC=0+100	24546	C4-1/8-T0-10R0-F
A30R8	0757-0422	5		RESISTOR 909 1% .125W F TC=0+100	24546	C4-1/8-T0-909R-F
A30R9	0757-0442	9	1	RESISTOR 10K 1% .125W F TC=0+100	24546	C4-1/8-T0-1002-F
A30R10	0757-0401	0	7	RESISTOR 100 1% .125W F TC=0+100	24546	C4-1/8-T0-101-F
A30R11	0757-0394	0	5	RESISTOR 51.1 1% .125W F TC=0+100	24546	C4-1/8-T0-511R1-F
A30R12	0757-0416	7	6	RESISTOR 511 1% .125W F TC=0+100	24546	C4-1/8-T0-511R-F
A30R13	0757-0394	0		RESISTOR 51.1 1% .125W F TC=0+100	24546	C4-1/8-T0-511R1-F
A30R14	0757-0416	7		RESISTOR 511 1% .125W F TC=0+100	24546	C4-1/8-T0-511R-F
A30R15	0757-0422	5		RESISTOR 909 1% .125W F TC=0+100	24546	C4-1/8-T0-909R-F
A30R16	0757-0401	0		RESISTOR 100 1% .125W F TC=0+100	24546	C4-1/8-T0-101-F
A30R17	0698-3150	6	8	RESISTOR 2.37K 1% .125W F TC=0+100	24546	C4-1/8-T0-2371-F
A30R18	0698-3150	6		RESISTOR 2.37K 1% .125W F TC=0+100	24546	C4-1/8-T0-2371-F
A30R19	0698-7198	0	2	RESISTOR 26.1 1% .05W F TC=0+100	24546	C3-1/8-T0-26R1-F
A30R20	0698-3443	0	5	RESISTOR 287 1% .125W F TC=0+100	24546	C4-1/8-T0-287R-F
A30R21	0698-3429	2	3	RESISTOR 19.6 1% .125W F TC=0+100	03888	PME55-1/8-T0-19R6-F
A30R22	0698-3443	0		RESISTOR 287 1% .125W F TC=0+100	24546	C4-1/8-T0-287R-F
A30R23	0698-3150	6		RESISTOR 2.37K 1% .125W F TC=0+100	24546	C4-1/8-T0-2371-F
A30R24	0757-0401	0		RESISTOR 100 1% .125W F TC=0+100	24546	C4-1/8-T0-101-F
A30R25	0698-3150	6		RESISTOR 2.37K 1% .125W F TC=0+100	24546	C4-1/8-T0-2371-F
A30R26	0757-0416	7		RESISTOR 511 1% .125W F TC=0+100	24546	C4-1/8-T0-511R-F
A30R27	0757-0346	2		RESISTOR 10 1% .125W F TC=0+100	24546	C4-1/8-T0-10R0-F
A30R28	0757-0422	5		RESISTOR 909 1% .125W F TC=0+100	24546	C4-1/8-T0-909R-F
A30R29	0698-7198	0		RESISTOR 26.1 1% .05W F TC=0+100	24546	C3-1/8-T0-26R1-F
A30R30	0698-3443	0		RESISTOR 287 1% .125W F TC=0+100	24546	C4-1/8-T0-287R-F
A30R31	0698-3429	2		RESISTOR 19.6 1% .125W F TC=0+100	03888	PME55-1/8-T0-19R6-F
A30R32	0698-3443	0		RESISTOR 287 1% .125W F TC=0+100	24546	C4-1/8-T0-287R-F
A30R33	0698-3443	0		RESISTOR 287 1% .125W F TC=0+100	24546	C4-1/8-T0-287R-F
A30R34	0698-3429	2		RESISTOR 19.6 1% .125W F TC=0+100	03888	PME55-1/8-T0-19R6-F

See introduction to this section for ordering information
 *Indicates factory selected value

Table 6-3. Model 8340A Replaceable Parts

Reference Designation	HP Part Number	C D	Qty	Description	Mfr Code	Mfr Part Number
A30R35	0698-7223	2	1	RESISTOR 287 1% .05W F TC=0+100	24546	C3-1/8-T0-287R-F
A30R36	0698-3150	6		RESISTOR 2.37K 1% .125W F TC=0+100	24546	C4-1/8-T0-2371-F
A30R37	0757-0422	5		RESISTOR 909 1% .125W F TC=0+100	24546	C4-1/8-T0-909R-F
A30R38	0757-0401	0		RESISTOR 100 1% .125W F TC=0+100	24546	C4-1/8-T0-101-F
A30R39	0698-3150	6		RESISTOR 2.37K 1% .125W F TC=0+100	24546	C4-1/8-T0-2371-F
A30R40	0757-0416	7		RESISTOR 511 1% .125W F TC=0+100	24546	C4-1/8-T0-511R-F
A30R41	0757-0394	0		RESISTOR 51.1 1% .125W F TC=0+100	24546	C4-1/8-T0-511R1-F
A30R42	0698-0084	9	3	RESISTOR 2.15K 1% .125W F TC=0+100	24546	C4-1/8-T0-2151-F
A30R43	0698-3155	1		RESISTOR 4.64K 1% .125W F TC=0+100	24546	C4-1/8-T0-4641-F
A30R44	0698-0084	9		RESISTOR 2.15K 1% .125W F TC=0+100	24546	C4-1/8-T0-2151-F
A30R45	0698-0084	9		RESISTOR 2.15K 1% .125W F TC=0+100	24546	C4-1/8-T0-2151-F
A30R46	0757-0279	0		RESISTOR 3.16K 1% .125W F TC=0+100	24546	C4-1/8-T0-3161-F
A30R47	0757-0439	4	2	RESISTOR 6.81K 1% .125W F TC=0+100	24546	C4-1/8-T0-6811-F
A30R48	0757-0416	7		RESISTOR 511 1% .125W F TC=0+100	24546	C4-1/8-T0-511R-F
A30R49	0757-0279	0		RESISTOR 3.16K 1% .125W F TC=0+100	24546	C4-1/8-T0-3161-F
A30R50	0757-0439	4		RESISTOR 6.81K 1% .125W F TC=0+100	24546	C4-1/8-T0-6811-F
A30R51	0757-0416	7		RESISTOR 511 1% .125W F TC=0+100	24546	C4-1/8-T0-511R-F
A30R52	0757-0280	3	2	RESISTOR 1K 1% .125W F TC=0+100	24546	C4-1/8-T0-1001-F
A30R53	0757-0394	0		RESISTOR 51.1 1% .125W F TC=0+100	24546	C4-1/8-T0-511R1-F
A30R54	0757-0394	0		RESISTOR 51.1 1% .125W F TC=0+100	24546	C4-1/8-T0-511R1-F
A30R55	0757-0422	5		RESISTOR 909 1% .125W F TC=0+100	24546	C4-1/8-T0-909R-F
A30R56	0698-3150	6		RESISTOR 2.37K 1% .125W F TC=0+100	24546	C4-1/8-T0-2371-F
A30R57	0757-0401	0		RESISTOR 100 1% .125W F TC=0+100	24546	C4-1/8-T0-101-F
A30R58	0757-0401	0		RESISTOR 100 1% .125W F TC=0+100	24546	C4-1/8-T0-101-F
A30R59	0698-3150	6		RESISTOR 2.37K 1% .125W F TC=0+100	24546	C4-1/8-T0-2371-F
A30R60	0757-0280	3		RESISTOR 1K 1% .125W F TC=0+100	24546	C4-1/8-T0-1001-F
A30R61	0757-0397	3	1	RESISTOR 68.1 1% .125W F TC=0+100	24546	C4-1/8-T0-6811-F
A30R62	0757-0401	0		RESISTOR 100 1% .125W F TC=0+100	24546	C4-1/8-T0-101-F
A30R63-66				NOT ASSIGNED		
A30R67*	0698-3437	2	2	RESISTOR 133 1% .125W F TC=0+100	24546	C4-1/8-T0-133R-F
A30R68*	0698-4037	0	1	RESISTOR 46.4 1% .125W F TC=0+100	24546	C4-1/8-T0-464R-F
A30R69*	0698-3437	2		RESISTOR 133 1% .125W F TC=0+100	24546	C4-1/8-T0-133R-F
A30T1	08553-6012	5	3	TRANSFORMER-RF (BLUE)	28480	08553-6012
A30T2	08553-6012	5		TRANSFORMER-RF (BLUE)	28480	08553-6012
A30T3	08553-6012	5		TRANSFORMER-RF (BLUE)	28480	08553-6012
A30TP1				NOT ASSIGNED		
A30TP2	0360-0535	0	3	TERMINAL TEST POINT PCB	00000	ORDER BY DESCRIPTION
A30TP3	0360-0535	0		TERMINAL TEST POINT PCB	00000	ORDER BY DESCRIPTION
A30TP4	0360-0535	0		TERMINAL TEST POINT PCB	00000	ORDER BY DESCRIPTION
A30W1	08340-60102	2	1	CABLE ASSEMBLY- A30	28480	08340-60102
A30Y1	0410-1086	5	1	CRYSTAL- 100.0 MHZ	28480	0410-1086

See introduction to this section for ordering information
 *Indicates factory selected value

Table 6-3. Model 8340A Replaceable Parts

Reference Designation	HP Part Number	C D	Qty	Description	Mfr Code	Mfr Part Number
A31	08340-60036	1	1	M/N PHASE DETECTOR	28480	08340-60036
A31C1	0160-4299	7	4	CAPACITOR-FXD 2200PF +20% 250VDC CER	56289	C067F251F222MS22-CDH
A31C2	0160-0574	3	6	CAPACITOR-FXD .022UF ±20% 100VDC CER	28480	0160-0574
A31C3	0160-4299	7		CAPACITOR-FXD 2200PF ±20% 250VDC CER	56289	C067F251F222MS22-CDH
A31C4	0180-0100	3	1	CAPACITOR-FXD 4.7UF+10% 35VDC TA	56289	150D475X9035B2
A31C5	0160-0572	1	2	CAPACITOR-FXD 2200PF +20% 100VDC CER	28480	0160-0572
A31C6	0160-0572	1		CAPACITOR-FXD 2200PF +20% 100VDC CER	28480	0160-0572
A31C7	0160-3876	4	2	CAPACITOR-FXD 47PF ±20% 200VDC CER	28480	0160-3876
A31C8	0160-3877	5	1	CAPACITOR-FXD 100PF +20% 200VDC CER	28480	0160-3877
A31C9	0160-3876	4		CAPACITOR-FXD 47PF ±20% 200VDC CER	28480	0160-3876
A31C10	0160-0574	3		CAPACITOR-FXD .022UF ±20% 100VDC CER	28480	0160-0574
A31C11	0160-3873	1	1	CAPACITOR-FXD 4.7PF +.5PF 200VDC CER	28480	0160-3873
A31C12	0160-0574	3		CAPACITOR-FXD .022UF ±20% 100VDC CER	28480	0160-0574
A31C13	0160-3878	6	3	CAPACITOR-FXD 1000PF ±20% 100VDC CER	28480	0160-3878
A31C14	0160-0574	3		CAPACITOR-FXD .022UF ±20% 100VDC CER	28480	0160-0574
A31C15	0160-3878	6		CAPACITOR-FXD 1000PF ±20% 100VDC CER	28480	0160-3878
A31C16	0160-3878	6		CAPACITOR-FXD 1000PF +20% 100VDC CER	28480	0160-3878
A31C17	0180-0197	8	1	CAPACITOR-FXD 2.2UF+10% 20VDC TA	56289	150D25X9020A2
A31C18	0160-4299	7		CAPACITOR-FXD 2200PF +20% 250VDC CER	56289	C067F251F222MS22-CDH
A31C19	0180-0291	3	1	CAPACITOR-FXD 1UF+10% 35VDC TA	56289	150D15X9035A2
A31C20	0160-0574	3		CAPACITOR-FXD .022UF ±20% 100VDC CER	28480	0160-0574
A31C21	0160-4299	7		CAPACITOR-FXD 2200PF +20% 250VDC CER	56289	C067F251F222MS22-CDH
A31C22	0160-0574	3		CAPACITOR-FXD .022UF ±20% 100VDC CER	28480	0160-0574
A31J1	1250-0690	6	1	CONNECTOR-RF MALE SMB	28480	1250-0690
A31L1	9100-1641	0	2	INDUCTOR RF-CH-MLD 240UH 5% .166DX.385LG	28480	9100-1641
A31L2	9100-2259	8	1	INDUCTOR RF-CH-MLD 1.5UH 10% .105DX.26LG	28480	9100-2259
A31L3	9100-1641	0		INDUCTOR RF-CH-MLD 240UH 5% .166DX.385LG	28480	9100-1641
A31L4	9100-2891	4	1	INDUCTOR RF-CH-MLD 50NH 10% .105DX.26LG	28480	9100-2891
A31L5				NOT ASSIGNED		
A31L6	9100-2248	5	3	INDUCTOR RF-CH-MLD 120NH 10% .105DX.26LG	28480	9100-2248
A31L7	9100-2248	5		INDUCTOR RF-CH-MLD 120NH 10% .105DX.26LG	28480	9100-2248
A31L8	9100-2248	5		INDUCTOR RF-CH-MLD 120NH 10% .105DX.26LG	28480	9100-2248
A31MP1, 2				NOT ASSIGNED		
A31MP3	0520-0129	8	13	SCREW-MACH 2-56 .312-IN-LG PAN-HD-POZI	00000	ORDER BY DESCRIPTION
A31MP4	0520-0129	8		SCREW-MACH 2-56 .312-IN-LG PAN-HD-POZI	00000	ORDER BY DESCRIPTION
A31MP5	0520-0129	8		SCREW-MACH 2-56 .312-IN-LG PAN-HD-POZI	00000	ORDER BY DESCRIPTION
A31MP6	0520-0129	8		SCREW-MACH 2-56 .312-IN-LG PAN-HD-POZI	00000	ORDER BY DESCRIPTION
A31MP7	0520-0129	8		SCREW-MACH 2-56 .312-IN-LG PAN-HD-POZI	00000	ORDER BY DESCRIPTION
A31MP8	0520-0129	8		SCREW-MACH 2-56 .312-IN-LG PAN-HD-POZI	00000	ORDER BY DESCRIPTION
A31MP9	0520-0129	8		SCREW-MACH 2-56 .312-IN-LG PAN-HD-POZI	00000	ORDER BY DESCRIPTION
A31MP10	0520-0129	8		SCREW-MACH 2-56 .312-IN-LG PAN-HD-POZI	00000	ORDER BY DESCRIPTION
A31MP11	0520-0129	8		SCREW-MACH 2-56 .312-IN-LG PAN-HD-POZI	00000	ORDER BY DESCRIPTION
A31MP12	0520-0129	8		SCREW-MACH 2-56 .312-IN-LG PAN-HD-POZI	00000	ORDER BY DESCRIPTION
A31MP13	0520-0129	8		SCREW-MACH 2-56 .312-IN-LG PAN-HD-POZI	00000	ORDER BY DESCRIPTION
A31MP14	0520-0129	8		SCREW-MACH 2-56 .312-IN-LG PAN-HD-POZI	00000	ORDER BY DESCRIPTION
A31MP15	0520-0129	8		SCREW-MACH 2-56 .312-IN-LG PAN-HD-POZI	00000	ORDER BY DESCRIPTION
A31MP16	0590-0533	5		THREADED INSERT-NUT 2-56 .06-IN-LG SST	28480	0590-0533
A31MP17	0590-0533	5		THREADED INSERT-NUT 2-56 .06-IN-LG SST	28480	0590-0533
A31MP18	0590-0533	5		THREADED INSERT-NUT 2-56 .06-IN-LG SST	28480	0590-0533
A31MP19	0590-0533	5		THREADED INSERT-NUT 2-56 .06-IN-LG SST	28480	0590-0533
A31MP20	0590-0533	5		THREADED INSERT-NUT 2-56 .06-IN-LG SST	28480	0590-0533
A31MP21	0590-0533	5		THREADED INSERT-NUT 2-56 .06-IN-LG SST	28480	0590-0533
A31MP22	0590-0533	5		THREADED INSERT-NUT 2-56 .06-IN-LG SST	28480	0590-0533
A31MP23	0590-0533	5		THREADED INSERT-NUT 2-56 .06-IN-LG SST	28480	0590-0533
A31MP24	0590-0533	5		THREADED INSERT-NUT 2-56 .06-IN-LG SST	28480	0590-0533
A31MP25	0590-0533	5		THREADED INSERT-NUT 2-56 .06-IN-LG SST	28480	0590-0533
A31MP26	0590-0533	5		THREADED INSERT-NUT 2-56 .06-IN-LG SST	28480	0590-0533
A31MP27	0590-0533	5		THREADED INSERT-NUT 2-56 .06-IN-LG SST	28480	0590-0533
A31MP28	0590-0533	5		THREADED INSERT-NUT 2-56 .06-IN-LG SST	28480	0590-0533
A31MP29	1205-0285	0	5	HEAT SINK SGL DIP	28480	1205-0285
A31MP30	1205-0285	0		HEAT SINK SGL DIP	28480	1205-0285
A31MP31	1205-0285	0		HEAT SINK SGL DIP	28480	1205-0285
A31MP32	1205-0285	0		HEAT SINK SGL DIP	28480	1205-0285
A31MP33	1205-0285	0		HEAT SINK SGL DIP	28480	1205-0285
A31MP34	2190-0014	1	3	WASHER-LK INTL T NO. 2 .06-IN-ID	28480	2190-0014
A31MP35	2190-0014	1		WASHER-LK INTL T NO. 2 .06-IN-ID	28480	2190-0014
A31MP36	2190-0014	1		WASHER-LK INTL T NO. 2 .06-IN-ID	28480	2190-0014
A31MP37	2190-0124	4	6	WASHER-LK INTL T NO. 10 .11-IN-ID	28480	2190-0124
A31MP38	2190-0124	4		WASHER-LK INTL T NO. 10 .11-IN-ID	28480	2190-0124
A31MP39	2190-0124	4		WASHER-LK INTL T NO. 10 .11-IN-ID	28480	2190-0124
A31MP40	2190-0124	4		WASHER-LK INTL T NO. 10 .11-IN-ID	28480	2190-0124
A31MP41	2190-0124	4		WASHER-LK INTL T NO. 10 .11-IN-ID	28480	2190-0124

See introduction to this section for ordering information
 *Indicates factory selected value.

Table 6-3. Model 8340A Replaceable Parts

Reference Designation	HP Part Number	C D	Qty	Description	Mfr Code	Mfr Part Number
A31MP42	2190-0124	4	10	WASHER-LK INTL T NO. 10 .195-IN-ID	28480	2190-0124
A31MP43	2190-0890	1		WASHER-LK HLCL NO. 2 .088-IN-ID	28480	2190-0890
A31MP44	2190-0890	1		WASHER-LK HLCL NO. 2 .088-IN-ID	28480	2190-0890
A31MP45	2190-0890	1		WASHER-LK HLCL NO. 2 .088-IN-ID	28480	2190-0890
A31MP46	2190-0890	1		WASHER-LK HLCL NO. 2 .088-IN-ID	28480	2190-0890
A31MP47	2190-0890	1		WASHER-LK HLCL NO. 2 .088-IN-ID	28480	2190-0890
A31MP48	2190-0890	1		WASHER-LK HLCL NO. 2 .088-IN-ID	28480	2190-0890
A31MP49	2190-0890	1		WASHER-LK HLCL NO. 2 .088-IN-ID	28480	2190-0890
A31MP50	2190-0890	1		WASHER-LK HLCL NO. 2 .088-IN-ID	28480	2190-0890
A31MP51	2190-0890	1		WASHER-LK HLCL NO. 2 .088-IN-ID	28480	2190-0890
A31MP52	2190-0890	1	WASHER-LK HLCL NO. 2 .088-IN-ID	28480	2190-0890	
A31MP53	2200-0101	0	2	SCREW-MACH 4-40 .188-IN-LG PAN-HD-POZI	00000	ORDER BY DESCRIPTION
A31MP54	2200-0101	0		SCREW-MACH 4-40 .188-IN-LG PAN-HD-POZI	00000	ORDER BY DESCRIPTION
A31MP55	2200-0103	2	2	SCREW-MACH 4-40 .25-IN-LG PAN-HD-POZI	00000	ORDER BY DESCRIPTION
A31MP56	2200-0103	2		SCREW-MACH 4-40 .25-IN-LG PAN-HD-POZI	00000	ORDER BY DESCRIPTION
A31MP57	2950-0078	9	3	NUT-HEX-DBL-CHAM 10-32-THD .067-IN-THK	28480	2950-0078
A31MP58	2950-0078	9		NUT-HEX-DBL-CHAM 10-32-THD .067-IN-THK	28480	2950-0078
A31MP59	2950-0078	9		NUT-HEX-DBL-CHAM 10-32-THD .067-IN-THK	28480	2950-0078
A31MP60	08340-20092	5	1	COVER-PC M/N PHASE DETECTOR	28480	08340-20092
A31MP61	85660-20068	4	2	GROUND LUG	28480	85660-20068
A31MP62	85660-20068	4		GROUND LUG	28480	85660-20068
A31MP63	86701-00032	2	1	HEAT SINK-IC	28480	86701-00032
A31MP64	86701-00033	3	1	BRACKET-HEAT SINK	28480	86701-00033
A31MP65	86701-40001	9	1	EXTRACTOR-PC BOARD	28480	86701-40001
A31MP66	1200-0172	4	1	INSULATOR-XSTR DAP-GL	28480	1200-0172
A31Q1	1853-0451	5	2	TRANSISTOR PNP 2N3799 SI TO-18 PD=360MW	01295	2N3799
A31Q2	1853-0451	5		TRANSISTOR PNP 2N3799 SI TO-18 PD=360MW	01295	2N3799
A31Q3	1854-0345	8	2	TRANSISTOR NPN 2N5179 SI TO-72 PD=200MW	04713	2N5179
A31Q4	1854-0345	8		TRANSISTOR NPN 2N5179 SI TO-72 PD=200MW	04713	2N5179
A31R1	0698-3154	0	5	RESISTOR 4.22K 1% .125W F TC=0+100	24546	C4-1/8-T0-4221-F
A31R2	0698-3154	0		RESISTOR 4.22K 1% .125W F TC=0+100	24546	C4-1/8-T0-4221-F
A31R3	0698-3154	0		RESISTOR 4.22K 1% .125W F TC=0+100	24546	C4-1/8-T0-4221-F
A31R4	0698-3154	0		RESISTOR 4.22K 1% .125W F TC=0+100	24546	C4-1/8-T0-4221-F
A31R5	0698-7267	4	1	RESISTOR 19.6K 1% .05W F TC=0+100	24546	C3-1/8-T0-1962-F
A31R6	0757-0401	0	1	RESISTOR 100 1% .125W F TC=0+100	24546	C4-1/8-T0-101-F
A31R7	0698-0083	8	2	RESISTOR 1.96K 1% .125W F TC=0+100	24546	C4-1/8-T0-1961-F
A31R8	0698-7192	4	2	RESISTOR 14.7 1% .05W F TC=0+100	24546	C3-1/8-T0-147-F
A31R9	0757-0280	3	2	RESISTOR 1K 1% .125W F TC=0+100	24546	C4-1/8-T0-1001-F
A31R10	0757-0280	3		RESISTOR 1K 1% .125W F TC=0+100	24546	C4-1/8-T0-1001-F
A31R11	0698-3154	0		RESISTOR 4.22K 1% .125W F TC=0+100	24546	C4-1/8-T0-4221-F
A31R12	0698-7212	9	1	RESISTOR 100 1% .05W F TC=0+100	24546	C3-1/8-T0-100R-F
A31R13	0698-3157	3	2	RESISTOR 19.6K 1% .125W F TC=0+100	24546	C4-1/8-T0-1962-F
A31R14	0757-0416	7	4	RESISTOR 511 1% .125W F TC=0+100	24546	C4-1/8-T0-511R-F
A31R15	0757-0416	7		RESISTOR 511 1% .125W F TC=0+100	24546	C4-1/8-T0-511R-F
A31R16	0698-7248	1	3	RESISTOR 3.16K 1% .05W F TC=0+100	24546	C3-1/8-T0-3161-F
A31R17	0698-7248	1		RESISTOR 3.16K 1% .05W F TC=0+100	24546	C3-1/8-T0-3161-F
A31R18	0698-7223	2	1	RESISTOR 287 1% .05W F TC=0+100	24546	C3-1/8-T0-287R-F
A31R19	0698-7256	1	1	RESISTOR 6.81K 1% .05W F TC=0+100	24546	C3-1/8-T0-6811-F
A31R20	0698-7248	1		RESISTOR 3.16K 1% .05W F TC=0+100	24546	C3-1/8-T0-3161-F
A31R21	0698-7220	9	2	RESISTOR 215 1% .05W F TC=0+100	24546	C3-1/8-T0-215R-F
A31R22	0698-7220	9		RESISTOR 215 1% .05W F TC=0+100	24546	C3-1/8-T0-215R-F
A31R23	0698-7192	4		RESISTOR 14.7 1% .05W F TC=0+100	24546	C3-1/8-T0-147-F
A31R24	0757-0416	7		RESISTOR 511 1% .125W F TC=0+100	24546	C4-1/8-T0-511R-F
A31R25	0757-0416	7		RESISTOR 511 1% .125W F TC=0+100	24546	C4-1/8-T0-511R-F
A31R26	0757-0441	8	2	RESISTOR 8.25K 1% .125W F TC=0+100	24546	C4-1/8-T0-8251-F
A31R27	0757-0441	8		RESISTOR 8.25K 1% .125W F TC=0+100	24546	C4-1/8-T0-8251-F
A31R28	0698-3157	3		RESISTOR 19.6K 1% .125W F TC=0+100	24546	C4-1/8-T0-1962-F
A31R29	0698-3162	0	1	RESISTOR 46.4K 1% .125W F TC=0+100	24546	C4-1/8-T0-4642-F
A31R30	0698-0083	8		RESISTOR 1.96K 1% .125W F TC=0+100	24546	C4-1/8-T0-1961-F
A31TP1	0360-0535	0	7	TERMINAL TEST POINT PCB	00000	ORDER BY DESCRIPTION
A31TP2	0360-0535	0		TERMINAL TEST POINT PCB	00000	ORDER BY DESCRIPTION
A31TP3	0360-0535	0		TERMINAL TEST POINT PCB	00000	ORDER BY DESCRIPTION
A31TP4	0360-0535	0		TERMINAL TEST POINT PCB	00000	ORDER BY DESCRIPTION
A31TP5	0360-0535	0		TERMINAL TEST POINT PCB	00000	ORDER BY DESCRIPTION
A31TP6	0360-0535	0		TERMINAL TEST POINT PCB	00000	ORDER BY DESCRIPTION
A31TP7	0360-0535	0		TERMINAL TEST POINT PCB	00000	ORDER BY DESCRIPTION
A31U1	1820-1344	8	1	IC PL LOOP 14-DIP-C PKG	04713	MC12040L
A31U2	1826-0092	3	1	IC OP AMP GP DUAL TO-99 PKG	28480	1826-0092
A31U3	1810-0251	3	3	NETWORK-RES 10-SIP MULTI-VALUE	28480	1810-0251
A31U4	1820-1225	4	2	IC FF ECL D-M/S DUAL	04713	MC10231P
A31U5	1810-0204	6	6	NETWORK-RES 8-SIP1.0K OHM X 7	01121	208A102
A31U6	1820-0821	4	2	IC CNTR ECL BIN UP/DOWN SYNCHRO	28480	1820-0821
A31U7	1820-0802	1	4	IC GATE ECL NOR QUAD 2-INP	04713	MC10102P
A31U8	1810-0204	6		NETWORK-RES 8-SIP1.0K OHM X 7	01121	208A102

See introduction to this section for ordering information
 *Indicates factory selected value

Table 6-3. Model 8340A Replaceable Parts

Reference Designation	HP Part Number	C D	Qty	Description	Mfr Code	Mfr Part Number
A31U9	1820-0806	5	2	IC GATE ECL OR-NOR DUAL 4-5-INP	04713	MC10109P
A31U10	1820-0820	3	2	IC FF ECL J-BAR K-BAR COM CLOCK DUAL	04713	MC10135L
A31U11	1810-0204	6		NETWORK-RES 8-SIP1.0K OHM X 7	01121	208A102
A31U12	1820-0802	1		IC GATE ECL NOR QUAD 2-INP	04713	MC10102P
A31U13	1810-0251	3		NETWORK-RES 10-SIP MULTI-VALUE	28480	1810-0251
A31U14	1820-1225	4		IC FF ECL D-M/S DUAL	04713	MC10231P
A31U15	1810-0204	6		NETWORK-RES 8-SIP1.0K OHM X 7	01121	208A102
A31U16	1820-0821	4		IC CNTR ECL BIN UP/DOWN SYNCHRO	28480	1820-0821
A31U17	1810-0251	3		NETWORK-RES 10-SIP MULTI-VALUE	28480	1810-0251
A31U18	1820-0802	1		IC GATE ECL NOR QUAD 2-INP	04713	MC10102P
A31U19	1810-0204	6		NETWORK-RES 8-SIP1.0K OHM X 7	01121	208A102
A31U20	1820-0806	5		IC GATE ECL OR-NOR DUAL 4-5-INP	04713	MC10109P
A31U21	1820-0820	3		IC FF ECL J-BAR K-BAR COM CLOCK DUAL	04713	MC10135L
A31U22	1810-0204	6		NETWORK-RES 8-SIP1.0K OHM X 7	01121	208A102
A31U23	1820-0802	1		IC GATE ECL NOR QUAD 2-INP	04713	MC10102P
A31U24	0955-0063	0	1	MIXER-DOUBLER 5-500 MH	28480	0955-0063
A31VR1	1902-3082	9	1	DIODE-ZNR 4.64V 5% DO-35 PD=.4W	28480	1902-3082
A31W1	08340-60103	3	1	CABLE ASSEMBLY- A31	28480	08340-60103
A31W2	08340-60104	4	1	CABLE ASSEMBLY- A31	28480	08340-60104

See introduction to this section for ordering information
 *Indicates factory selected value

Table 6-3. Model 8340A Replaceable Parts

Reference Designation	HP Part Number	C D	Qty	Description	Mfr Code	Mfr Part Number
A32	08340-60091	8	1	M/N VCO ASSEMBLY (08340-60091 INCLUDES A32A1 M/N VCO PC BD AND A32A2 VCO)	28480	08340-60091
A32/A33	08340-60092	9	1	M/N-VCO/OUTPUT ASSEMBLY (INCLUDES A32 M/N VCO ASSY. AND A33 M/N OUTPUT ASSY)	28480	08340-60092
A32A1				M/N VCO PC BOARD ASSEMBLY (NSR)		
A32A1C1	0160-3878	6	21	CAPACITOR-FXD 1000PF +20% 100VDC CER	28480	0160-3878
A32A1C2	0160-3878	6		CAPACITOR-FXD 1000PF ±20% 100VDC CER	28480	0160-3878
A32A1C3	0160-3879	7	2	CAPACITOR-FXD .01UF +20% 100VDC CER	28480	0160-3879
A32A1C4	0160-3878	6		CAPACITOR-FXD 1000PF +20% 100VDC CER	28480	0160-3878
A32A1C5	0180-0116	1	1	CAPACITOR-FXD 6.8UF±10% 35VDC TA	56289	150D685X9035B2
A32A1C6	0160-3878	6		CAPACITOR-FXD 1000PF +20% 100VDC CER	28480	0160-3878
A32A1C7	0160-3878	6		CAPACITOR-FXD 1000PF ±20% 100VDC CER	28480	0160-3878
A32A1C8	0160-3873	1	3	CAPACITOR-FXD 4.7PF +.5PF 200VDC CER	28480	0160-3873
A32A1C9	0160-3878	6		CAPACITOR-FXD 1000PF +20% 100VDC CER	28480	0160-3878
A32A1C10	0160-3879	7		CAPACITOR-FXD .01UF ±20% 100VDC CER	28480	0160-3879
A32A1C11	0180-2161	0	1	CAPACITOR-FXD .75UF±10% 50VDC TA	56289	150D754X9050A2
A32A1J1	1251-0600	0	3	CONNECTOR-SGL CONT PIN 1.14-MM-BSC-SZ SQ	28480	1251-0600
A32A1J2	1251-0600	0		CONNECTOR-SGL CONT PIN 1.14-MM-BSC-SZ SQ	28480	1251-0600
A32A1J3	1251-0600	0		CONNECTOR-SGL CONT PIN 1.14-MM-RSC-SZ SQ	28480	1251-0600
A32A1L1	9100-0346	0	2	INDUCTOR RF-CH-MLD 50NH 20% .105DX.26LG	28480	9100-0346
A32A1L2	9100-0346	0		INDUCTOR RF-CH-MLD 50NH 20% .105DX.26LG	28480	9100-0346
A32A1L3	86701-20051	7	1	INDUCTOR	28480	86701-20051
A32A1L4	9140-0158	6	3	INDUCTOR RF-CH-MLD 1UH 10% .105DX.26LG	28480	9140-0158
A32A1MPI	0590-0526	6	1	THREADED INSERT-NUT 4-40 .065-IN-LG SST	28480	0590-0526
A32A1Q1	1854-0686	0	1	TRANSISTOR NPN SI TO-72 PD=200MW FT=4GHZ	28480	1854-0686
A32A1Q2	1854-0610	0	1	TRANSISTOR NPN SI TO-46 FT=800MHZ	28480	1854-0610
A32A1R1	0757-0280	3	2	RESISTOR 1K 1% .125W F TC=0+100	24546	C4-1/8-T0-1001-F
A32A1R2	0698-7219	6	1	RESISTOR 196 1% .05W F TC=0±100	24546	C3-1/8-T0-196R-F
A32A1R3	0698-7193	5	1	RESISTOR 16.2 1% .05W F TC=0+100	24546	C3-1/8-T0-16R2-F
A32A1R4	0698-3154	0	1	RESISTOR 4.22K 1% .125W F TC=0+100	24546	C4-1/8-T0-4221-F
A32A1R5	0757-0428	1	2	RESISTOR 1.62K 1% .125W F TC=0±100	24546	C4-1/8-T0-1621-F
A32A1R6	0698-7262	9	1	RESISTOR 12.1K 1% .05W F TC=0+100	24546	C3-1/8-T0-1212-F
A32A1R7	0757-0428	1		RESISTOR 1.62K 1% .125W F TC=0+100	24546	C4-1/8-T0-1621-F
A32A1R8	0698-7254	9	1	RESISTOR 5.62K 1% .05W F TC=0+100	24546	C3-1/8-T0-5621-F
A32A1R9	0698-7205	0	2	RESISTOR 51.1 1% .05W F TC=0+100	24546	C3-1/8-T0-51R1-F
A32A1R10	0698-7265	2	1	RESISTOR 16.2K 1% .05W F TC=0+100	24546	C3-1/8-T0-1622-F
A32A1R11	0698-7250	5	1	RESISTOR 3.83K 1% .05W F TC=0+100	24546	C3-1/8-T0-3831-F
A32A1R12	0757-0401	0	1	RESISTOR 100 1% .125W F TC=0+100	24546	C4-1/8-T0-101-F
A32A1R13	0757-0400	9	1	RESISTOR 90.9 1% .125W F TC=0±100	24546	C4-1/8-T0-90R9-F
A32A1W1	08340-60105	5	1	CABLE ASSEMBLY-COAX A32	28480	08340-60105
A32A1W2				NOT ASSIGNED		
A32A1W3	86701-20050	6	1	CABLE-JUMPER	28480	86701-20050
	1251-2313	6	2	CONNECTOR-SGL CONT SKT .04-IN-BSC-SZ RND	28480	1251-2313
A32A2				M/N VCO (NSR)		

See introduction to this section for ordering information
 *Indicates factory selected value

Table 6-3. Replaceable Parts

Reference Designation	HP Part Number	C D	Qty	Description	Mfr Code	Mfr Part Number
A33	08340-60038	3	1	M/N OUTPUT	28480	08340-60038
A33C1	0160-3878	6		CAPACITOR-FXD 1000PF +20% 100VDC CER	28480	0160-3878
A33C2	0160-3878	6		CAPACITOR-FXD 1000PF +20% 100VDC CER	28480	0160-3878
A33C3	0160-3874	2	3	CAPACITOR-FXD 10PF +.5PF 200VDC CER	28480	0160-3874
A33C4	0160-3878	6		CAPACITOR-FXD 1000PF +20% 100VDC CER	28480	0160-3878
A33C5	0160-3878	6		CAPACITOR-FXD 1000PF +20% 100VDC CER	28480	0160-3878
A33C6	0160-3873	1		CAPACITOR-FXD 4.7PF +.5PF 200VDC CER	28480	0160-3873
A33C7	0160-3878	6		CAPACITOR-FXD 1000PF +20% 100VDC CER	28480	0160-3878
A33C8	0160-3873	1		CAPACITOR-FXD 4.7PF +.5PF 200VDC CER	28480	0160-3873
A33C9	0160-4491	1		CAPACITOR-FXD 8.2PF +.5PF 200VDC CER	28480	0160-4491
A33C10	0160-4490	0	1	CAPACITOR-FXD 1.8PF +.25PF 200VDC CER	28480	0160-4490
A33C11				NOT ASSIGNED		
A33C12	0160-2261	9	1	CAPACITOR-FXD 15PF +5% 500VDC CER 0+30	28480	0160-2261
A33C13	0160-2290	4	2	CAPACITOR-FXD .15UF +10% 80VDC POLYE	28480	0160-2290
A33C14	0160-2290	4		CAPACITOR-FXD .15UF +10% 80VDC POLYE	28480	0160-2290
A33C15	0140-0196	3	1	CAPACITOR-FXD 150PF +5% 300VDC MICA	72136	DM15F151J0300WV1CR
A33C16	0160-3878	6		CAPACITOR-FXD 1000PF +20% 100VDC CER	28480	0160-3878
A33C17	0160-3878	6		CAPACITOR-FXD 1000PF +20% 100VDC CER	28480	0160-3878
A33C18	0160-3874	2		CAPACITOR-FXD 10PF +.5PF 200VDC CER	28480	0160-3874
A33C19	0160-3876	4	1	CAPACITOR-FXD 47PF +20% 200VDC CER	28480	0160-3876
A33C20	0160-3878	6		CAPACITOR-FXD 1000PF +20% 100VDC CER	28480	0160-3878
A33C21	0160-3878	6		CAPACITOR-FXD 1000PF +20% 100VDC CER	28480	0160-3878
A33C22	0160-3878	6		CAPACITOR-FXD 1000PF +20% 100VDC CER	28480	0160-3878
A33C23	0160-4351	2	1	CAPACITOR-FDTHRU 1000PF 20% 200V CER	28480	0160-4351
A33C24	0160-0161	4	2	CAPACITOR-FXD .01UF +10% 200VDC POLYE	28480	0160-0161
A33C25	0160-0153	4	1	CAPACITOR-FXD 1000PF +10% 200VDC POLYE	28480	0160-0153
A33C26	0160-0161	4		CAPACITOR-FXD .01UF +10% 200VDC POLYE	28480	0160-0161
A33C27	0160-3534	1	1	CAPACITOR-FXD 510PF +5% 100VDC MICA	28480	0160-3534
A33C28	0160-0298	8	1	CAPACITOR-FXD 1500PF +10% 200VDC POLYE	28480	0160-0298
A33C29	0180-0197	8	2	CAPACITOR-FXD 2.2UF+10% 20VDC TA	56289	150D225X9020A2
A33C30	0160-3878	6		CAPACITOR-FXD 1000PF +20% 100VDC CER	28480	0160-3878
A33C31	0180-0197	8		CAPACITOR-FXD 2.2UF+10% 20VDC TA	56289	150D225X9020A2
A33C32	0160-3878	6		CAPACITOR-FXD 1000PF +20% 100VDC CER	28480	0160-3878
A33C33	0160-3878	6		CAPACITOR-FXD 1000PF +20% 100VDC CER	28480	0160-3878
A33C34	0160-3878	6		CAPACITOR-FXD 1000PF +20% 100VDC CER	28480	0160-3878
A33C35	0160-3878	6		CAPACITOR-FXD 1000PF +20% 100VDC CER	28480	0160-3878
A33CR1	1901-0040	1	4	DIODE-SWITCHING 30V 50MA 2NS DO-35	28480	1901-0040
A33CR2	1901-0040	1		DIODE-SWITCHING 30V 50MA 2NS DO-35	28480	1901-0040
A33CR3	1901-0040	1		DIODE-SWITCHING 30V 50MA 2NS DO-35	28480	1901-0040
A33CR4	1901-0040	1		DIODE-SWITCHING 30V 50MA 2NS DO-35	28480	1901-0040
A33J1	1250-0690	6	2	CONNECTOR-RF MALE SMB	28480	1250-0690
A33J2	1250-0690	6		CONNECTOR-RF MALE SMB	28480	1250-0690
A33J3	1250-1889	7	1	CONNECTOR-RF SMB M PC 50-OHM	28480	1250-1889
A33L1	9135-0073	3	8	INDUCTOR RF-CH-MLD 51NH 6% .102DX.26LG	28480	9135-0073
A33L2	9135-0073	3		INDUCTOR RF-CH-MLD 51NH 6% .102DX.26LG	28480	9135-0073
A33L3	9135-0073	3		INDUCTOR RF-CH-MLD 51NH 6% .102DX.26LG	28480	9135-0073
A33L4	9135-0073	3		INDUCTOR RF-CH-MLD 51NH 6% .102DX.26LG	28480	9135-0073
A33L5				NOT ASSIGNED		
A33L6	9100-1634	1	1	INDUCTOR RF-CH-MLD 75UH 5% .166DX.385LG	28480	9100-1634
A33L7	9100-1635	2	1	INDUCTOR RF-CH-MLD 91UH 5% .166DX.385LG	28480	9100-1635
A33L8	9100-1620	5	1	INDUCTOR RF-CH-MLD 15UH 10% .166DX.385LG	28480	9100-1620
A33L9	9140-0210	1	1	INDUCTOR RF-CH-MLD 100UH 5% .166DX.385LG	28480	9140-0210
A33L10	9135-0073	3		INDUCTOR RF-CH-MLD 51NH 6% .102DX.26LG	28480	9135-0073
A33L11	9135-0073	3		INDUCTOR RF-CH-MLD 51NH 6% .102DX.26LG	28480	9135-0073
A33L12	9135-0079	9		INDUCTOR RF-CH-MLD 100NH 5.5% .102DX.26LG	28480	9135-0079
A33L13	9135-0073	3		INDUCTOR RF-CH-MLD 51NH 6% .102DX.26LG	28480	9135-0073
A33L14	9140-0144	0	1	INDUCTOR RF-CH-MLD 4.7UH 10% .105DX.26LG	28480	9140-0144
A33MP1	1200-0172	4	7	INSULATOR-XSTR DAP-GL	28480	1200-0172
A33MP2	1200-0172	4		INSULATOR-XSTR DAP-GL	28480	1200-0172
A33MP3	1200-0172	4		INSULATOR-XSTR DAP-GL	28480	1200-0172
A33MP4	1200-0172	4		INSULATOR-XSTR DAP-GL	28480	1200-0172
A33MP5	1200-0172	4		INSULATOR-XSTR DAP-GL	28480	1200-0172
A33MP6	1200-0172	4		INSULATOR-XSTR DAP-GL	28480	1200-0172
A33MP7	1200-0172	4		INSULATOR-XSTR DAP-GL	28480	1200-0172
A33MP8	2190-0009	4	1	WASHER-LK INTL T NO. 8 .168-IN-ID	28480	2190-0009
A33MP9	2190-0124	4	4	WASHER-LK INTL T NO. 10 .195-IN-ID	28480	2190-0124
A33MP10	2190-0124	4		WASHER-LK INTJ T NO. 10 .195-IN-ID	28480	2190-0124
A33MP11	2190-0124	4		WASHER-LK INTL T NO. 10 .195-IN-ID	28480	2190-0124
A33MP12	2190-0124	4		WASHER-LK INTL T NO. 10 .195-IN-ID	28480	2190-0124
A33MP13	2200-0101	0	4	SCREW-MACH 4-40 .188-IN-LG PAN-HD-POZI	00000	ORDER BY DESCRIPTION
A33MP14	2200-0101	0		SCREW-MACH 4-40 .188-IN-LG PAN-HD-POZI	00000	ORDER BY DESCRIPTION
A33MP15	2200-0101	0		SCREW-MACH 4-40 .188-IN-LG PAN-HD-POZI	00000	ORDER BY DESCRIPTION

See introduction to this section for ordering information
 *Indicates factory selected value

Table 6-3. Replaceable Parts

Reference Designation	HP Part Number	C D	Qty	Description	Mfr Code	Mfr Part Number
A33MP16	2200-0101	0		SCREW-MACH 4-40 .188-IN-LG PAN-HD-POZI	00000	ORDER BY DESCRIPTION
A33MP17	2590-0002	4	1	NUT-HEX-DBL-CHAM 8-32-THD .085-IN-THK	00000	ORDER BY DESCRIPTION
A33MP18	2950-0078	9	2	NUT-HEX-DBL-CHAM 10-32-THD .067-IN-THK	28480	2950-0078
A33MP19	2950-0078	9		NUT-HEX-DBL-CHAM 10-32-THD .067-IN-THK	28480	2950-0078
A33MP20	3050-0082	8	1	WASHER-FL NM NO. 4 .116-IN-ID .188-IN-OD	28480	3050-0082
A33MP21	4330-0145	9	2	INSULATOR-BEAD GLASS	28480	4330-0145
A33MP22	4330-0145	9		INSULATOR-BEAD GLASS	28480	4330-0145
A33MP23	08340-20093	6	1	COVER-PC M/N OUTPUT	28480	08340-20093
A33MP24	85660-20068	4	2	GROUND LUG	28480	85660-20068
A33MP25	85660-20068	4		GROUND LUG	28480	85660-20068
A33MP26	86701-40001	9	1	EXTRACTOR-PC	28480	86701-40001
A33Q1	1854-0345	8	7	TRANSISTOR NPN 2N5179 SI TO-72 PD=200MW	04713	2N5179
A33Q2	1854-0345	8		TRANSISTOR NPN 2N5179 SI TO-72 PD=200MW	04713	2N5179
A33Q3	1854-0345	8		TRANSISTOR NPN 2N5179 SI TO-72 PD=200MW	04713	2N5179
A33Q4	1854-0345	8		TRANSISTOR NPN 2N5179 SI TO-72 PD=200MW	04713	2N5179
A33Q5	1854-0345	8		TRANSISTOR NPN 2N5179 SI TO-72 PD=200MW	04713	2N5179
A33Q6	1854-0345	8		TRANSISTOR NPN 2N5179 SI TO-72 PD=200MW	04713	2N5179
A33Q7	1854-0345	8		TRANSISTOR NPN 2N5179 SI TO-72 PD=200MW	04713	2N5179
A33R1	0698-7212	9	4	RESISTOR 100 1% .05W F TC=0+-100	24546	C3-1/8-T0-100R-F
A33R2	0698-7248	1	5	RESISTOR 3.16K 1% .05W F TC=0+-100	24546	C3-1/8-T0-3161-F
A33R3	0698-7243	6	4	RESISTOR 1.96K 1% .05W F TC=0+-100	24546	C3-1/8-T0-1961-F
A33R4	0698-7205	0		RESISTOR 51.1 1% .05W F TC=0+-100	24546	C3-1/8-T0-511R-F
A33R5	0698-7223	2	3	RESISTOR 287 1% .05W F TC=0+-100	24546	C3-1/8-T0-287R-F
A33R6	0698-7248	1		RESISTOR 3.16K 1% .05W F TC=0+-100	24546	C3-1/8-T0-3161-F
A33R7	0698-7243	6		RESISTOR 1.96K 1% .05W F TC=0+-100	24546	C3-1/8-T0-1961-F
A33R8	0757-0316	6	1	RESISTOR 42.2 1% .125W F TC=0+-100	24546	C4-1/8-T0-42R2-F
A33R9	0698-7221	0	1	RESISTOR 237 1% .05W F TC=0+-100	24546	C3-1/8-T0-237R-F
A33R10	0698-7188	8	3	RESISTOR 10 1% .05W F TC=0+-100	24546	C3-1/8-T0-10R-F
A33R11	0698-7212	9		RESISTOR 100 1% .05W F TC=0+-100	24546	C3-1/8-T0-100R-F
A33R12	0757-0394	0	1	RESISTOR 51.1 1% .125W F TC=0+-100	24546	C4-1/8-T0-511R-F
A33R13	0698-7212	9		RESISTOR 100 1% .05W F TC=0+-100	24546	C3-1/8-T0-100R-F
A33R14	0757-1094	9	4	RESISTOR 1.47K 1% .125W F TC=0+-100	24546	C4-1/8-T0-1471-F
A33R15	0757-1094	9		RESISTOR 1.47K 1% .125W F TC=0+-100	24546	C4-1/8-T0-1471-F
A33R16	0757-1094	9		RESISTOR 1.47K 1% .125W F TC=0+-100	24546	C4-1/8-T0-1471-F
A33R17	0757-1094	9		RESISTOR 1.47K 1% .125W F TC=0+-100	24546	C4-1/8-T0-1471-F
A33R18	0757-0290	5	1	RESISTOR 6.19K 1% .125W F TC=0+-100	19701	MF4C1/8-T0-6191-F
A33R19	0698-7248	1		RESISTOR 3.16K 1% .05W F TC=0+-100	24546	C3-1/8-T0-3161-F
A33R20	0698-7222	1	1	RESISTOR 261 1% .05W F TC=0+-100	24546	C3-1/8-T0-261R-F
A33R21	0698-7223	2		RESISTOR 287 1% .05W F TC=0+-100	24546	C3-1/8-T0-287R-F
A33R22	0698-7188	8		RESISTOR 10 1% .05W F TC=0+-100	24546	C3-1/8-T0-10R-F
A33R23	0698-7229	8	2	RESISTOR 511 1% .05W F TC=0+-100	24546	C3-1/8-T0-511R-F
A33R24	0698-7212	9		RESISTOR 100 1% .05W F TC=0+-100	24546	C3-1/8-T0-100R-F
A33R25	0698-7248	1		RESISTOR 3.16K 1% .05W F TC=0+-100	24546	C3-1/8-T0-3161-F
A33R26	0698-7243	6		RESISTOR 1.96K 1% .05W F TC=0+-100	24546	C3-1/8-T0-1961-F
A33R27	0698-7248	1		RESISTOR 3.16K 1% .05W F TC=0+-100	24546	C3-1/8-T0-3161-F
A33R28	0698-7229	8		RESISTOR 511 1% .05W F TC=0+-100	24546	C3-1/8-T0-511R-F
A33R29	0698-7243	6		RESISTOR 1.96K 1% .05W F TC=0+-100	24546	C3-1/8-T0-1961-F
A33R30	0698-7195	7	1	RESISTOR 19.6 1% .05W F TC=0+-100	24546	C3-1/8-T0-19R6-F
A33R31	0698-7227	6	1	RESISTOR 422 1% .05W F TC=0+-100	24546	C3-1/8-T0-422R-F
A33R32	0698-7188	8		RESISTOR 10 1% .05W F TC=0+-100	24546	C3-1/8-T0-10R-F
A33R33	0757-0290	3		RESISTOR 1K 1% .125W F TC=0+-100	24546	C4-1/8-T0-1001-F
A33R34	0757-0279	0	1	RESISTOR 3.16K 1% .125W F TC=0+-100	24546	C4-1/8-T0-3161-F
A33R35	0698-7223	2		RESISTOR 287 1% .05W F TC=0+-100	24546	C3-1/8-T0-287R-F
A33R36	0698-7210	7	1	RESISTOR 82.5 1% .05W F TC=0+-100	24546	C3-1/8-T0-82R5-F
A33R37	0698-3442	9	1	RESISTOR 237 1% .125W F TC=0+-100	24546	C3-1/8-T0-257R-F
A33U1	1826-0059	2	1	IC OP AMP GP TO-99 PKG	01295	LM201AL
A33U2	1820-2642	1	1	IC CNTR ECL BIN DUAL	28480	1820-2642
A33VR1	1902-3070	5	2	DIODE-ZNR 4.22V 5% DO-35 PD=.4W	28480	1902-3070
A33VR2	1902-3070	5		DIODE-ZNR 4.22V 5% DO-35 PD=.4W	28480	1902-3070
A33W1	08340-60123	7	1	JUMPER WIRE ASSEMBLY	28480	08340-60123

See Introduction to the Catalog for ordering information.

Units are factory standard values.

Table 6-3. Model 8340A Replaceable Parts

Reference Designation	HP Part Number	C D	Qty	Description	Mfr Code	Mfr Part Number
A34	08340-60039	4	1	REFERENCE M/N MOTHERBOARD	28480	08340-60039
A34C1	0160-2437	1	12	CAPACITOR-FDTHRU 5000PF +80 -20% 200V	28480	0160-2437
A34C2	0160-2437	1		CAPACITOR-FDTHRU 5000PF +80 -20% 200V	28480	0160-2437
A34C3	0160-2437	1		CAPACITOR-FDTHRU 5000PF +80 -20% 200V	28480	0160-2437
A34C4	0160-2437	1		CAPACITOR-FDTHRU 5000PF +80 -20% 200V	28480	0160-2437
A34C5	0160-2437	1		CAPACITOR-FDTHRU 5000PF +80 -20% 200V	28480	0160-2437
A34C6	0160-2437	1		CAPACITOR-FDTHRU 5000PF +80 -20% 200V	28480	0160-2437
A34C7	0160-2437	1		CAPACITOR-FDTHRU 5000PF +80 -20% 200V	28480	0160-2437
A34C8	0160-2437	1		CAPACITOR-FDTHRU 5000PF +80 -20% 200V	28480	0160-2437
A34C9	0160-2437	1		CAPACITOR-FDTHRU 5000PF +80 -20% 200V	28480	0160-2437
A34C10	0160-2437	1		CAPACITOR-FDTHRU 5000PF +80 -20% 200V	28480	0160-2437
A34C11	0160-2437	1		CAPACITOR-FDTHRU 5000PF +80 -20% 200V	28480	0160-2437
A34C12	0160-2437	1		CAPACITOR-FDTHRU 5000PF +80 -20% 200V	28480	0160-2437
A34C13	0160-4083	7	2	CAPACITOR-FDTHRU 10PF 10% 200V CER	28480	0160-4083
A34C14	0160-4083	7		CAPACITOR-FDTHRU 10PF 10% 200V CER	28480	0160-4083
A34E1-9	9170-0029	3	12	CORE-SHIELDING BEAD	28480	9170-0029
A34E10-12				NOT ASSIGNED		
A34E13-26	9170-0029	3		CORE-SHIELDING BEAD	28480	9170-0029
A34MP1	8150-0014	3	1	WIRE-24 AWG 1 X 24	28480	8150-0014
A34MP2	2190-0007	2	2	WASHER-LK INTL T NO. 6 .141-IN-ID	28480	2190-0007
A34MP3	2420-0003	7	2	NUT-HEX-DBL-CHAM 6-32-THD .094-IN-THK	00000	ORDER BY DESCRIPTION
A34MP4	2190-0843	4	12	WASHER-LK INTL T NO. 8 .165-IN-ID	28480	2190-0843
A34MP5	2580-0002	4	12	NUT-HEX-DBL-CHAM 8-32-THD .085-IN-THK	00000	ORDER BY DESCRIPTION
A34MP6	8150-0447	6	1	WIRE-24 AWG 300V 0	28480	8150-0447
A34MP7	85660-00037	5	1	INSULATOR- 15 PIN (FOR XA33)	28480	85660-00037
A34MP8	1251-0600	0	1	CONNECTOR-SGL CONT PIN 1.14-MM-BSC-SZ SQ	28480	1251-0600
A34MP9	0890-0983	5		TUBING-HEAT SINK .125ID	28480	0890-0983
A34MP10	8150-0464	7	3	WIRE-24 AWG 300V 97	28480	8150-0464
A34MP11	8150-0454	5	3	WIRE-24 AWG 300V 7	28480	8150-0454
A34MP12	8150-0449	8	2	WIRE-24 AWG 300V 2	28480	8150-0449
A34MP13	8150-0451	2	3	WIRE-24 AWG 300V 4	28480	8150-0451
A34MP14	8150-0472	7	2	WIRE-24 AWG 300V 907	28480	8150-0472
A34MP15	8150-0464	7		WIRE-24 AWG 300V 97	28480	8150-0464
A34MP16	8150-0454	5		WIRE-24 AWG 300V 7	28480	8150-0454
A34MP17	8150-0449	8		WIRE-24 AWG 300V 2	28480	8150-0449
A34MP18	8150-0451	2		WIRE-24 AWG 300V 4	28480	8150-0451
A34MP19	8150-0451	2		WIRE-24 AWG 300V 4	28480	8150-0451
A34MP20	8150-0464	7		WIRE-24 AWG 300V 97	28480	8150-0464
A34MP21	8150-0472	7		WIRE-24 AWG 300V 907	28480	8150-0472
A34MP22	8150-0454	5		WIRE-24 AWG 300V 7	28480	8150-0454
A34MP23	8150-0461	4	1	WIRE-24 AWG 300V 94	28480	8150-0461
A34XA29	1251-4423	3	1	CONNECTOR-PC EDGE 15-CONT/ROW 1-ROW	28480	1251-4423
	85660-00051	3	1	INSULATOR- 15 PIN (FOR XA29)	28480	85660-00051
A34XA30	1251-4174	1	1	CONNECTOR-PC EDGE 15-CONT/ROW 1-ROW	28480	1251-4174
	85660-00050	2	1	INSULATOR- 15 PIN (FOR XA30)	28480	85660-00050
A34XA31	1251-2035	9	1	CONNECTOR-PC EDGE 15-CONT/ROW 2-ROWS	28480	1251-2035
A34XA32				NOT ASSIGNED		
A34XA33	1251-5020	8	1	CONNECTOR-PC 15 IR	28480	1251-5020
A34XA34A	5060-0112	8	1	CONNECTOR- 15 CONTACT DIP	28480	5060-0112
A34XA34B	5060-0112	8		CONNECTOR- 15 CONTACT DIP	28480	5060-0112

See introduction to this section for ordering information
 *Indicates factory selected value

Table 6-3. Model 8340A Replaceable Parts

Reference Designation	HP Part Number	C D	Qty	Description	Mfr Code	Mfr Part Number
A35	08340-60002	1	1	RECTIFIER	28480	08340-60002
A35C1	0160-3638	6	1	CAPACITOR-FXD .22UF +80-20% 200VDC CER	28480	0160-3638
	0360-0535	0	5	TERMINAL TEST POINT PCB	00000	ORDER BY DESCRIPTION
A35C2	0160-4005	3	3	CAPACITOR-FXD 1UF +20% 100VDC CER	28480	0160-4005
	0360-0535	0		TERMINAL TEST POINT PCB	00000	ORDER BY DESCRIPTION
A35C3	0160-4005	3		CAPACITOR-FXD 1UF +20% 100VDC CER	28480	0160-4005
	0360-0535	0		TERMINAL TEST POINT PCB	00000	ORDER BY DESCRIPTION
A35C4	0160-4005	3		CAPACITOR-FXD 1UF +20% 100VDC CER	28480	0160-4005
	0360-0535	0		TERMINAL TEST POINT PCB	00000	ORDER BY DESCRIPTION
A35C5	0160-2055	9	2	CAPACITOR-FXD .01UF +80-20% 100VDC CER	28480	0160-2055
	0360-0535	0		TERMINAL TEST POINT PCB	00000	ORDER BY DESCRIPTION
A35C6	0160-0128	3	1	CAPACITOR-FXD 2.2UF +20% 50VDC CER	28480	0160-0128
A35C7	0160-2055	9		CAPACITOR-FXD .01UF +80-20% 100VDC CER	28480	0160-2055
A35C8	0160-3094	8	2	CAPACITOR-FXD .1UF +10% 100VDC CER	28480	0160-3094
A35C9	0160-3094	8		CAPACITOR-FXD .1UF +10% 100VDC CER	28480	0160-3094
A35C10	0180-2129	0	1	CAPACITOR-FXD 10UF+10% 50VDC TA	56289	150D106X9050R2
A35CR1	1901-0662	3	6	DIODE-PWR RECT 100V 6A	04713	MR751
A35CR2	1901-0662	3		DIODE-PWR RECT 100V 6A	04713	MR751
A35CR3	1901-0662	3		DIODE-PWR RECT 100V 6A	04713	MR751
A35CR4	1901-0662	3		DIODE-PWR RECT 100V 6A	04713	MR751
A35CR5	1901-0662	3		DIODE-PWR RECT 100V 6A	04713	MR751
A35CR6	1901-0028	5	1	DIODE-PWR RECT 400V 750MA DO-29	28480	1901-0028
A35CR7	1901-0662	3		DIODE-PWR RECT 100V 6A	04713	MR751
A35DS1	1990-0487	7	1	LED-LAMP LUM-INT=LMCD IF=20MA-MAX BVR=5V	28480	5082-4584
A35F1	2110-0425	0	1	FUSE 2A 125V .25X.27	28480	2110-0425
A35MP1, 2				NOT ASSIGNED		
A35MP3	0590-0526	6	1	THREADED INSERT-NUT 4-40 .065-IN-LG SST	28480	0590-0526
A35MP4	1200-0081	4	1	INSULATOR-FLG-BSHG NYLON	28480	1200-0081
A35MP5	2200-0107	6	4	SCREW-MACH 4-40 .375-IN-LG PAN-HD-POZI	00000	ORDER BY DESCRIPTION
A35MP6	6040-0454	0		THERMAL COMPOUND SYNTH	28480	6040-0454
A35MP7	08340-00009	2	1	HEAT SINK RECTIFIER	28480	08340-00009
A35P1	1251-2313	6	2	CONNECTOR-SGL CONT SKT .04-IN-BSC-SZ RND	28480	1251-2313
A35P2	1251-2313	6		CONNECTOR-SGL CONT SKT .04-IN-BSC-SZ RND	28480	1251-2313
A35Q1	1884-0018	5	2	THYRISTOR-SCR 2N4186 VRRM=200	04713	2N4186
A35Q2	1884-0018	5		THYRISTOR-SCR 2N4186 VRRM=200	04713	2N4186
A35R1	0757-0401	0	1	RESISTOR 100 1% .125W F TC=0+100	24546	C4-1/8-T0-101-F
A35R2	0698-3406	5	1	RESISTOR 1.33K 1% .5W F TC=0+100	28480	0698-3406
A35R3	2100-3123	0	1	RESISTOR-TRMR 500 10% C SIDE-ADJ 17-TRN	02111	43P501
A35R4	0698-0082	7	1	RESISTOR 464 1% .125W F TC=0+100	24546	C4-1/8-T0-4640-F
A35R5	0757-0346	2	1	RESISTOR 10 1% .125W F TC=0+100	24546	C4-1/8-T0-10R0-F
A35R6	0698-3444	1	1	RESISTOR 316 1% .125W F TC=0+100	24546	C4-1/8-T0-316R-F
A35R7	0698-3447	4	1	RESISTOR 422 1% .125W F TC=0+100	24546	C4-1/8-T0-422R-F
A35U1	1906-0239	0	1	DIODE-CT-RECT 45V 30A	01281	SD-241
A35U2	1826-0423	4	1	IC V RGLTR TO-3	27014	LM317K
A35VR1	1902-0197	1	1	DIODE-ZNR 82V 5% PD=1W IR=5UA	28480	1902-0197
A35VR2	1902-1249	6	1	DIODE-ZNR 24.9V 5% DO-15 PD=1W TC=+.081%	28480	1902-1249
A35VR3	1902-0202	9	1	DIODE-ZNR 15V 5% PD=1W IR=5UA	28480	1902-0202

See introduction to this section for ordering information
 *Indicates factory selected value

Table 6-3. Replaceable Parts

Reference Designation	HP Part Number	C D	Qty	Description	Mfr Code	Mfr Part Number
A36	08340-60042	9	1	PLL1 VCO	28480	08340-60042
A36C1	0160-0574	3	8	CAPACITOR-FXD .022UF +-20% 100VDC CER	28480	0160-0574
A36C2	0160-0574	3		CAPACITOR-FXD .022UF +-20% 100VDC CER	28480	0160-0574
A36C3	0160-3875	3	3	CAPACITOR-FXD 22PF +-5% 200VDC CER 0+-30	28480	0160-3875
A36C4	0160-0574	3		CAPACITOR-FXD .022UF +-20% 100VDC CER	28480	0160-0574
A36C5	0160-3877	5	1	CAPACITOR-FXD 100PF +-20% 200VDC CER	28480	0160-3877
A36C6	0160-0574	3		CAPACITOR-FXD .022UF +-20% 100VDC CER	28480	0160-0574
A36C7	0160-3875	3		CAPACITOR-FXD 22PF +-5% 200VDC CER 0+-30	28480	0160-3875
A36C8	0160-0574	3		CAPACITOR-FXD .022UF +-20% 100VDC CER	28480	0160-0574
A36C9	0160-3878	6	3	CAPACITOR-FXD 1000PF +-20% 100VDC CER	28480	0160-3878
A36C10	0160-3874	2	5	CAPACITOR-FXD 10PF +-5PF 200VDC CER	28480	0160-3874
A36C11	0160-3878	6		CAPACITOR-FXD 1000PF +-20% 100VDC CER	28480	0160-3878
A36C12	0160-3874	2		CAPACITOR-FXD 10PF +-5PF 200VDC CER	28480	0160-3874
A36C13	0160-3874	2		CAPACITOR-FXD 10PF +-5PF 200VDC CER	28480	0160-3874
A36C14	0160-3878	6		CAPACITOR-FXD 1000PF +-20% 100VDC CER	28480	0160-3878
A36C15	0160-3874	2		CAPACITOR-FXD 10PF +-5PF 200VDC CER	28480	0160-3874
A36C16	0160-3874	2		CAPACITOR-FXD 10PF +-5PF 200VDC CER	28480	0160-3874
A36C17	0160-3875	3		CAPACITOR-FXD 22PF +-5% 200VDC CER 0+-30	28480	0160-3875
A36C18	0160-4084	8	1	CAPACITOR-FXD .1UF +-20% 50VDC CER	28480	0160-4084
A36C19	0160-0574	3		CAPACITOR-FXD .022UF +-20% 100VDC CER	28480	0160-0574
A36C20	0160-0574	3		CAPACITOR-FXD .022UF +-20% 100VDC CER	28480	0160-0574
A36C21	0160-4953	0	4	CAPACITOR-CER .027 UF 50VDC	28480	0160-4953
A36C22	0160-4953	0		CAPACITOR-CER .027 UF 50VDC	28480	0160-4953
A36C23	0160-4953	0		CAPACITOR-CER .027 UF 50VDC	28480	0160-4953
A36C24	0160-4951	8	3	CAPACITOR-FXD .033UF +-5% 50VDC CER	28480	0160-4951
A36C25	0160-4952	9	1	CAPACITOR-FXD .039UF +-5% 50VDC CER	28480	0160-4952
A36C26	0160-0158	9	1	CAPACITOR-FXD 5600PF +-10% 200VDC POLYE	28480	0160-0158
A36C27	0180-0116	1	2	CAPACITOR-FXD 6.8UF+-10% 35VDC TA	56289	150D685X9035B2
A36C28	0180-0116	1		CAPACITOR-FXD 6.8UF+-10% 35VDC TA	56289	150D685X9035B2
A36C29	0180-0291	3	1	CAPACITOR-FXD .1UF+-10% 35VDC TA	56289	150D105X9035A2
A36C30	0180-0197	8	2	CAPACITOR-FXD 2.2UF+-10% 20VDC TA	56289	150D225X9020A2
A36C31	0160-4953	0		CAPACITOR-CER .027 UF 50VDC	28480	0160-4953
A36C32	0160-4298	6	1	CAPACITOR-FXD 4700PF +-20% 250VDC CER	56289	C067F251H472MS22-CDH
A36C33	0160-4951	8		CAPACITOR-FXD .033UF +-5% 50VDC CER	28480	0160-4951
A36C34	0160-4951	8		CAPACITOR-FXD .033UF +-5% 50VDC CER	28480	0160-4951
A36C35	0160-0574	3		CAPACITOR-FXD .022UF +-20% 100VDC CER	28480	0160-0574
A36C36	0180-0197	8		CAPACITOR-FXD 2.2UF+-10% 20VDC TA	56289	150D225X9020A2
A36CR1	1901-0040	1	5	DIODE-SWITCHING 30V 50MA 2NS DO-35	28480	1901-0040
A36CR2	1901-0040	1		DIODE-SWITCHING 30V 50MA 2NS DO-35	28480	1901-0040
A36CR3	0122-0085	1	2	DIODE-VVC 2.2PF 7% C3/C25-MIN=4.5	02032	SMV1288
A36CR4	0122-0085	1		DIODE-VVC 2.2PF 7% C3/C25-MIN=4.5	02032	SMV1288
A36CR5	1901-0040	1		DIODE-SWITCHING 30V 50MA 2NS DO-35	28480	1901-0040
A36CR6	1901-0040	1		DIODE-SWITCHING 30V 50MA 2NS DO-35	28480	1901-0040
A36CR7	1901-0040	1		DIODE-SWITCHING 30V 50MA 2NS DO-35	28480	1901-0040
A36J1	1250-0690	6	2	CONNECTOR-RF MALE SMB	28480	1250-0690
A36J2	1250-0690	6		CONNECTOR-RF MALE SMB	28480	1250-0690
A36L1	9100-2257	6	2	INDUCTOR RF-CH-MLD 820NH 10% .105DX.26LG	28480	9100-2257
A36L2	9100-2891	4	1	INDUCTOR RF-CH-MLD 50NH 10% .105DX.26LG	28480	9100-2891
A36L3	9100-2257	6		INDUCTOR RF-CH-MLD 820NH 10% .105DX.26LG	28480	9100-2257
A36L4	85660-80004	4	1	INDUCTOR- 30 NH	28480	85660-80004
A36L5	85660-80005	5	1	INDUCTOR- 4 NH	28480	85660-80005
A36L6	9100-2258	7	2	INDUCTOR RF-CH-MLD 1.2UH 10% .105DX.26LG	28480	9100-2258
A36L7	85660-80008	8	2	INDUCTOR-ADJ .4 MH	28480	85660-80008
A36L8	85660-80008	8		INDUCTOR-ADJ .4 MH	28480	85660-80008
A36L9	9100-1647	6	1	INDUCTOR RF-CH-MLD 4 70UH 5% .2DX.45LG	28480	9100-1647
A36L10	9100-1788	6	3	CHOKE-WIDE BAND ZMAX=680 OHM@ 180 MHZ	02114	VK200 20/48
A36L11	9100-1788	6		CHOKE-WIDE BAND ZMAX=680 OHM@ 180 MHZ	02114	VK200 20/48
A36L12	9100-1788	6		CHOKE-WIDE BAND ZMAX=680 OHM@ 180 MHZ	02114	VK200 20/48
A36L13	9100-2258	7		INDUCTOR RF-CH-MLD 1.2UH 10% .105DX.26LG	28480	9100-2258
A36L14	9100-2254	3	2	INDUCTOR RF-CH-MLD 390NH 10% .105DX.26LG	28480	9100-2254
A36L15	9100-2254	3		INDUCTOR RF-CH-MLD 390NH 10% .105DX.26LG	28480	9100-2254
A36L16	9100-2247	4	1	INDUCTOR RF-CH-MLD 100NH 10% .105DX.26LG	28480	9100-2247
A36MP1	2190-0124	4	6	WASHER-LK INTL T NO. 10 .195-IN-ID	28480	2190-0124
A36MP2	2190-0124	4		WASHER-LK INTL T NO. 10 .195-IN-ID	28480	2190-0124
A36MP3	2190-0124	4		WASHER-LK INTL T NO. 10 .195-IN-ID	28480	2190-0124
A36MP4	2190-0124	4		WASHER-LK INTL T NO. 10 .195-IN-ID	28480	2190-0124
A36MP5	2190-0124	4		WASHER-LK INTL T NO. 10 .195-IN-ID	28480	2190-0124
A36MP6	2190-0124	4		WASHER-LK INTL T NO. 10 .195-IN-ID	28480	2190-0124
A36MP7	2200-0101	0	2	SCREW-MACH 4-40 .188-IN-LG PAN-HD-POZI	00000	ORDER BY DESCRIPTION
A36MP8	2200-0101	0		SCREW-MACH 4-40 .188-IN-LG PAN-HD-POZI	00000	ORDER BY DESCRIPTION
A36MP9	86701-40001	9	1	EXTRAC TOR PC BOARD	28480	86701-40001

See introduction to this section for ordering information.

*Indicates factory selected value.

Table 6-3. Model 8340A Replaceable Parts

Reference Designation	HP Part Number	C D	Qty	Description	Mfr Code	Mfr Part Number
A36MP10	2950-0078	9		NUT-HEX-DBL-CHAM 10-32-THD .067-IN-THK	28480	2950-0078
A36MP11	2950-0078	9		NUT-HEX-DBL-CHAM 10-32-THD .067-IN-THK	28480	2950-0078
A36MP12	08340-20094	7	1	COVER-PC PLL1 VCO	28480	08340-20094
A36MP13	85660-00038	6	1	SHIELDING CAN	28480	85660-00038
A36MP14	85660-20068	4	3	GROUND LUG	28480	85660-20068
A36MP15	85660-20068	4		GROUND LUG	28480	85660-20068
A36MP16	85660-20068	4		GROUND LUG	28480	85660-20068
A36Q1	1855-0420	2	4	TRANSISTOR J-FET 2N4391 N-CHAN D-MODE	01295	2N4391
A36Q2	1854-0023	9	3	TRANSISTOR NPN SI TO-18 PD=360MW	28480	1854-0023
A36Q3	1854-0345	8	4	TRANSISTOR NPN 2N5179 SI TO-72 PD=200MW	04713	2N5179
A36Q4	1854-0345	8		TRANSISTOR NPN 2N5179 SI TO-72 PD=200MW	04713	2N5179
A36Q5	1854-0345	8		TRANSISTOR NPN 2N5179 SI TO-72 PD=200MW	04713	2N5179
A36Q6	1855-0420	2		TRANSISTOR J-FET 2N4391 N-CHAN D-MODE	01295	2N4391
A36Q7	1855-0420	2		TRANSISTOR J-FET 2N4391 N-CHAN D-MODE	01295	2N4391
A36Q8	1855-0420	2		TRANSISTOR J-FET 2N4391 N-CHAN D-MODE	01295	2N4391
A36Q9	1854-0023	9		TRANSISTOR NPN SI TO-18 PD=360MW	28480	1854-0023
A36Q10	1854-0023	9		TRANSISTOR NPN SI TO-18 PD=360MW	28480	1854-0023
A36Q11	1854-0345	8		TRANSISTOR NPN 2N5179 SI TO-72 PD=200MW	04713	2N5179
A36R1	0757-0395	1	2	RESISTOR 56.2 1% .125W F TC=0+100	24546	C4-1/8-T0-56R2-F
A36R2	0757-0280	3	11	RESISTOR 1K 1% .125W F TC=0+100	24546	C4-1/8-T0-1001-F
A36R3	0757-0317	7	1	RESISTOR 1.33K 1% .125W F TC=0+100	24546	C4-1/8-T0-1331-F
A36R4	0757-0441	8	2	RESISTOR 8.25K 1% .125W F TC=0+100	24546	C4-1/8-T0-8251-F
A36R5	0757-0280	3		RESISTOR 1K 1% .125W F TC=0+100	24546	C4-1/8-T0-1001-F
A36R6	0757-0123	3	4	RESISTOR 34.8K 1% .125W F TC=0+100	28480	0757-0123
A36R7	0757-0441	8		RESISTOR 8.25K 1% .125W F TC=0+100	24546	C4-1/8-T0-8251-F
A36R8	0757-0280	3		RESISTOR 1K 1% .125W F TC=0+100	24546	C4-1/8-T0-1001-F
A36R9	0698-3444	1	1	RESISTOR 316 1% .125W F TC=0+100	24546	C4-1/8-T0-316R-F
A36R10	0757-0460	1	1	RESISTOR 61.9K 1% .125W F TC=0+100	24546	C4-1/8-T0-6192-F
A36R11	0757-0280	3		RESISTOR 1K 1% .125W F TC=0+100	24546	C4-1/8-T0-1001-F
A36R12	0698-0082	7	1	RESISTOR 464 1% .125W F TC=0+100	24546	C4-1/8-T0-4640-F
A36R13	0757-0428	1	2	RESISTOR 1.62K 1% .125W F TC=0+100	24546	C4-1/8-T0-1621-F
A36R14	0757-0280	3		RESISTOR 1K 1% .125W F TC=0+100	24546	C4-1/8-T0-1001-F
A36R15	0757-0402	1	2	RESISTOR 110 1% .125W F TC=0+100	24546	C4-1/8-T0-111-F
A36R16	0698-7195	7	1	RESISTOR 19.6 1% .05W F TC=0+100	24546	C3-1/8-T0-19R6-F
A36R17	0757-0280	3		RESISTOR 1K 1% .125W F TC=0+100	24546	C4-1/8-T0-1001-F
A36R18	0698-3155	1	1	RESISTOR 4.64K 1% .125W F TC=0+100	24546	C4-1/8-T0-4641-F
A36R19	0757-0428	1		RESISTOR 1.62K 1% .125W F TC=0+100	24546	C4-1/8-T0-1621-F
A36R20	0757-0395	1		RESISTOR 56.2 1% .125W F TC=0+100	24546	C4-1/8-T0-56R2-F
A36R21	0698-3438	3	2	RESISTOR 147 1% .125W F TC=0+100	24546	C4-1/8-T0-147R-F
A36R22	0698-3438	3		RESISTOR 147 1% .125W F TC=0+100	24546	C4-1/8-T0-147R-F
A36R23	0757-0458	7	2	RESISTOR 51.1K 1% .125W F TC=0+100	24546	C4-1/8-T0-5112-F
A36R24	0757-0289	2	3	RESISTOR 13.3K 1% .125W F TC=0+100	19701	MF4C1/8-T0-1332-F
A36R25	0757-0289	2		RESISTOR 13.3K 1% .125W F TC=0+100	19701	MF4C1/8-T0-1332-F
A36R26	0757-0416	7	4	RESISTOR 511 1% .125W F TC=0+100	24546	C4-1/8-T0-511R-F
A36R27	0757-0123	3		RESISTOR 34.8K 1% .125W F TC=0+100	28480	0757-0123
A36R28	0757-0123	3		RESISTOR 34.8K 1% .125W F TC=0+100	28480	0757-0123
A36R29	0757-0440	7	2	RESISTOR 7.5K 1% .125W F TC=0+100	24546	C4-1/8-T0-7501-F
A36R30	0757-0440	7		RESISTOR 7.5K 1% .125W F TC=0+100	24546	C4-1/8-T0-7501-F
A36R31	0757-0465	6	1	RESISTOR 100K 1% .125W F TC=0+100	24546	C4-1/8-T0-1003-F
A36R32	0757-0289	2		RESISTOR 13.3K 1% .125W F TC=0+100	19701	MF4C1/8-T0-1332-F
A36R33	0698-3159	5	1	RESISTOR 26.1K 1% .125W F TC=0+100	24546	C4-1/8-T0-2612-F
A36R34	0757-0290	5	1	RESISTOR 6.19K 1% .125W F TC=0+100	19701	MF4C1/8-T0-6191-F
A36R35	0757-0458	7		RESISTOR 51.1K 1% .125W F TC=0+100	24546	C4-1/8-T0-5112-F
A36R36	0757-0402	1		RESISTOR 110 1% .125W F TC=0+100	24546	C4-1/8-T0-111-F
A36R37	0757-0442	9	1	RESISTOR 10K 1% .125W F TC=0+100	24546	C4-1/8-T0-1002-F
A36R38	0757-0123	3		RESISTOR 34.8K 1% .125W F TC=0+100	28480	0757-0123
A36R39	0757-0416	7		RESISTOR 511 1% .125W F TC=0+100	24546	C4-1/8-T0-511R-F
A36R40	0757-0416	7		RESISTOR 511 1% .125W F TC=0+100	24546	C4-1/8-T0-511R-F
A36R41	0757-0416	7		RESISTOR 511 1% .125W F TC=0+100	24546	C4-1/8-T0-511R-F
A36R42	0698-7188	8	1	RESISTOR 10 1% .05W F TC=0+100	24546	C3-1/8-T0-10R-F
A36R43	0757-0280	3		RESISTOR 1K 1% .125W F TC=0+100	24546	C4-1/8-T0-1001-F
A36R44	0757-0280	3		RESISTOR 1K 1% .125W F TC=0+100	24546	C4-1/8-T0-1001-F
A36R45	0757-0280	3		RESISTOR 1K 1% .125W F TC=0+100	24546	C4-1/8-T0-1001-F
A36R46	0757-0280	3		RESISTOR 1K 1% .125W F TC=0+100	24546	C4-1/8-T0-1001-F
A36R47	0757-0280	3		RESISTOR 1K 1% .125W F TC=0+100	24546	C4-1/8-T0-1001-F
A36R48	0757-0462	3	4	RESISTOR 75K 1% .125W F TC=0+100	24546	C4-1/8-T0-7502-F
A36R49	0757-0462	3		RESISTOR 75K 1% .125W F TC=0+100	24546	C4-1/8-T0-7502-F
A36R50	0757-0462	3		RESISTOR 75K 1% .125W F TC=0+100	24546	C4-1/8-T0-7502-F
A36R51	0757-0462	3		RESISTOR 75K 1% .125W F TC=0+100	24546	C4-1/8-T0-7502-F
A36TP1	0360-0535	0	4	TERMINAL TEST POINT PCB	00000	ORDER BY DESCRIPTION
A36TP2	0360-0535	0		TERMINAL TEST POINT PCB	00000	ORDER BY DESCRIPTION
A36TP3	0360-0535	0		TERMINAL TEST POINT PCB	00000	ORDER BY DESCRIPTION

See introduction to this section for ordering information
 *Indicates factory selected value

Table 6-3. Model 8340A Replaceable Parts

Reference Designation	HP Part Number	C D	Qty	Description	Mfr Code	Mfr Part Number
A36TP4	0360-0535	0		TERMINAL TEST POINT PCB	00000	ORDER BY DESCRIPTION
A36U1	1810-0204	6	1	NETWORK-RES 8-SIP 1.0K OHM X 7	01121	208A102
A36U2	1820-0802	1	1	IC GATE ECL NOR QUAD 2-INP	04713	MC10102P
A36U3	1820-1888	5	1	IC PRESCR ECL	04713	MC12013L
A36U4	1826-0161	7	1	IC OP AMP GP QUAD 14-DIP-P PKG	04713	MLM324P
A36U5	1820-1195	7	1	IC FF TTL LS D-TYPE POS-EDGE-TRIG COM	01295	SN74LS175N
A36U6	1826-0092	3	1	IC OP AMP GP DUAL TO-99 PKG	28480	1826-0092
A36VR1	1902-3048	7	1	DIODE-ZNR 3.48V 5% DO-35 PD=.4W	28480	1902-3048
A36W1	08340-60106	6	1	CABLE ASSEMBLY- A36	28480	08340-60106

See introduction to this section for ordering information
 *Indicates factory selected value

Table 6-3. Model 8340A Replaceable Parts

Reference Designation	HP Part Number	C D	Qty	Description	Mfr Code	Mfr Part Number
A37	08340-60043	0	1	PLLI DIVIDER	28480	08340-60043
A37C1	0160-0574	3	8	CAPACITOR-FXD .022UF +20% 100VDC CER	28480	0160-0574
A37C2	0160-0574	3		CAPACITOR-FXD .022UF +20% 100VDC CER	28480	0160-0574
A37C3	0160-0574	3		CAPACITOR-FXD .022UF +20% 100VDC CER	28480	0160-0574
A37C4	0160-0574	3		CAPACITOR-FXD .022UF +20% 100VDC CER	28480	0160-0574
A37C5	0160-0574	3		CAPACITOR-FXD .022UF +20% 100VDC CER	28480	0160-0574
A37C6	0160-0574	3	2	CAPACITOR-FXD .022UF +20% 100VDC CER	28480	0160-0574
A37C7	0160-0570	9		CAPACITOR-FXD 220PF +20% 100VDC CER	20932	5024EM100RD221M
A37C8	0160-0570	9		CAPACITOR-FXD 220PF +20% 100VDC CER	20932	5024EM100RD221M
A37C9	0160-0574	3		CAPACITOR-FXD .022UF +20% 100VDC CER	28480	0160-0574
A37C10	0160-4084	8		CAPACITOR-FXD .1UF +20% 50VDC CER	28480	0160-4084
A37C11	0160-3875	3	1	CAPACITOR-FXD 22PF +5% 200VDC CER 0+30	28480	0160-3875
A37C12	0160-0574	3		CAPACITOR-FXD .022UF +20% 100VDC CER	28480	0160-0574
A37C13	0180-2207	5		CAPACITOR-FXD 100UF+10% 10VDC TA	56289	150D107X9010R2
A37CR1	1901-0040	1	2	DIODE-SWITCHING 30V 50MA 2NS DO-35	28480	1901-0040
A37CR2	1901-0040	1		DIODE-SWITCHING 30V 50MA 2NS DO-35	28480	1901-0040
A37DS1	1990-0485	5	1	LFD-LAMP LUM-INT=800UCD IF=30MA-MAX	28480	5082-4984
A37J1	1250-0690	6	1	CONNECTOR-RF MALE SMB	28480	1250-0690
A37L1	9100-2255	4	1	INDUCTOR RF-CH-MLD 470NH 10% .105DX.26LG	28480	9100-2255
A37L2	9100-1788	6		CHOKE-WIDE BAND ZMAX=680 OHM@ 180 MHZ	02114	VK200 20/48
A37MP1	0520-0128	7	2	SCREW-MACH 2-56 .25-IN-LG PAN-HD-POZI	00000	ORDER BY DESCRIPTION
A37MP2	0520-0128	7		SCREW-MACH 2-56 .25-IN-LG PAN-HD-POZI	00000	ORDER BY DESCRIPTION
A37MP3	0590-0533	5	2	THREADED INSERT-NUT 2-56 .06-IN-LG SST	28480	0590-0533
A37MP4	0590-0533	5		THREADED INSERT-NUT 2-56 .06-IN-LG SST	28480	0590-0533
A37MP5	1205-0285	0	1	HEAT SINK SGL DIP	28480	1205-0285
A37MP6	2190-0014	1	2	WASHER-LK INTL T NO. 2 .089-IN-ID	28480	2190-0014
A37MP7	2190-0014	1		WASHER-LK INTL T NO. 2 .089-IN-ID	28480	2190-0014
A37MP8	2190-0124	4	4	WASHER-LK INTL T NO. 10 .195-IN-ID	28480	2190-0124
A37MP9	2190-0124	4		WASHER-LK INTL T NO. 10 .195-IN-ID	28480	2190-0124
A37MP10	2190-0124	4		WASHER-LK INTL T NO. 10 .195-IN-ID	28480	2190-0124
A37MP11	2190-0124	4		WASHER-LK INTL T NO. 10 .195-IN-ID	28480	2190-0124
A37MP12	2200-0101	0	2	SCREW-MACH 4-40 .188-IN-LG PAN-HD-POZI	00000	ORDER BY DESCRIPTION
A37MP13	2200-0101	0		SCREW-MACH 4-40 .188-IN-LG PAN-HD-POZI	00000	ORDER BY DESCRIPTION
A37MP14	2950-0078	9	2	NUT-HEX-DBL-CHAM 10-32-THD .067-IN-THK	28480	2950-0078
A37MP15	2950-0078	9		NUT-HEX-DBL-CHAM 10-32-THD .067-IN-THK	28480	2950-0078
A37MP16	08340-20083	4	1	COVER-PC PLLI DIVIDER	28480	08340-20083
A37MP17	85660-00012	6	1	HEAT SINK- BOT TOM	28480	85660-00012
A37MP18	85660-20068	4	2	GROUND LUG	28480	85660-20068
A37MP19	85660-20068	4	2	GROUND LUG	28480	85660-20068
A37MP20	86701-40001	9	2	EXTRACTOR-PC BOARD	28480	86701-40001
A37MP21	86701-40001	9	2	EXTRACTOR-PC BOARD	28480	86701-40001
A37Q1	1853-0405	9	1	TRANSISTOR PNP SI PD=300MW FT=850MHZ	04713	2N4209
A37Q2	1853-0451	5	2	TRANSISTOR PNP 2N3799 SI TO-18 PD=360MW	01295	2N3799
A37Q3	1853-0451	5		TRANSISTOR PNP 2N3799 SI TO-18 PD=360MW	01295	2N3799
A37R1	0757-0280	3	19	RESISTOR 1K 1% .125W F TC=0+100	24546	C4-1/8-T0-1001-F
A37R2	0698-3431	6		RESISTOR 23.7 1% .125W F TC=0+100	03888	PME55-1/8-T0-23R7-F
A37R3	0757-0403	2		RESISTOR 121 1% .125W F TC=0+100	24546	C4-1/8-T0-121R-F
A37R4	0757-0280	3		RESISTOR 1K 1% .125W F TC=0+100	24546	C4-1/8-T0-1001-F
A37R5	0757-0280	3		RESISTOR 1K 1% .125W F TC=0+100	24546	C4-1/8-T0-1001-F
A37R6	0757-0394	0	1	RESISTOR 51.1 1% .125W F TC=0+100	24546	C4-1/8-T0-51R1-F
A37R7	0757-0416	7	5	RESISTOR 511 1% .125W F TC=0+100	24546	C4-1/8-T0-511R-F
A37R8	0757-0416	7		RESISTOR 511 1% .125W F TC=0+100	24546	C4-1/8-T0-511R-F
A37R9	0698-0083	8		RESISTOR 511 1% .125W F TC=0+100	24546	C4-1/8-T0-511R-F
A37R10	0698-3440	7	4	RESISTOR 1.96K 1% .125W F TC=0+100	24546	C4-1/8-T0-1961-F
A37R11	0757-0280	3	1	RESISTOR 196 1% .125W F TC=0+100	24546	C4-1/8-T0-196R-F
A37R12	0757-0416	7		RESISTOR 1K 1% .125W F TC=0+100	24546	C4-1/8-T0-1001-F
A37R13	0757-0416	7		RESISTOR 511 1% .125W F TC=0+100	24546	C4-1/8-T0-511R-F
A37R14	0698-3440	7		RESISTOR 196 1% .125W F TC=0+100	24546	C4-1/8-T0-196R-F
A37R15	0757-0442	9		RESISTOR 10K 1% .125W F TC=0+100	24546	C4-1/8-T0-1002-F
A37R16	0757-0280	3		RESISTOR 1K 1% .125W F TC=0+100	24546	C4-1/8-T0-1001-F
A37R17	0698-3440	7		RESISTOR 196 1% .125W F TC=0+100	24546	C4-1/8-T0-196R-F
A37R18	0757-0280	3		RESISTOR 1K 1% .125W F TC=0+100	24546	C4-1/8-T0-1001-F
A37R19	0757-0280	3		RESISTOR 1K 1% .125W F TC=0+100	24546	C4-1/8-T0-1001-F
A37R20	0757-0280	3	RESISTOR 1K 1% .125W F TC=0+100	24546	C4-1/8-T0-1001-F	
A37R21	0757-0280	3	3	RESISTOR 1K 1% .125W F TC=0+100	24546	C4-1/8-T0-1001-F
A37R22	0757-0280	3		RESISTOR 1K 1% .125W F TC=0+100	24546	C4-1/8-T0-1001-F
A37R23	0757-0280	3		RESISTOR 1K 1% .125W F TC=0+100	24546	C4-1/8-T0-1001-F
A37R24	0757-0280	3		RESISTOR 1K 1% .125W F TC=0+100	24546	C4-1/8-T0-1001-F
A37R25	0757-0280	3		RESISTOR 1K 1% .125W F TC=0+100	24546	C4-1/8-T0-1001-F

See introduction to this section for ordering information
 *Indicates factory selected value

Table 6-3. Model 8340A Replaceable Parts

Reference Designation	HP Part Number	C D	Qty	Description	Mfr Code	Mfr Part Number
A37R26	0757-0280	3		RESISTOR 1K 1% .125W F TC=0+100	24546	C4-1/8-T0-1001-F
A37R27	0757-0280	3		RESISTOR 1K 1% .125W F TC=0+100	24546	C4-1/8-T0-1001-F
A37R28	0757-0280	3		RESISTOR 1K 1% .125W F TC=0+100	24546	C4-1/8-T0-1001-F
A37R29	0757-0280	3		RESISTOR 1K 1% .125W F TC=0+100	24546	C4-1/8-T0-1001-F
A37R30	0757-0416	7		RESISTOR 511 1% .125W F TC=0+100	24546	C4-1/8-T0-511R-F
A37R31	0698-3440	7		RESISTOR 196 1% .125W F TC=0+100	24546	C4-1/8-T0-196R-F
A37R32	0757-0403	2		RESISTOR 121 1% .125W F TC=0+100	24546	C4-1/8-T0-121R-F
A37R33	0757-0419	0	1	RESISTOR 681 1% .125W F TC=0+100	24546	C4-1/8-T0-681R-F
A37R34	0757-0280	3		RESISTOR 1K 1% .125W F TC=0+100	24546	C4-1/8-T0-1001-F
A37R35	0757-0280	3		RESISTOR 1K 1% .125W F TC=0+100	24546	C4-1/8-T0-1001-F
A37TP1	0360-0535	0	14	TERMINAL TEST POINT PCB	00000	ORDER BY DESCRIPTION
A37TP2	0360-0535	0		TERMINAL TEST POINT PCB	00000	ORDER BY DESCRIPTION
A37TP3	0360-0535	0		TERMINAL TEST POINT PCB	00000	ORDER BY DESCRIPTION
A37TP4	0360-0535	0		TERMINAL TEST POINT PCB	00000	ORDER BY DESCRIPTION
A37TP5	0360-0535	0		TERMINAL TEST POINT PCB	00000	ORDER BY DESCRIPTION
A37TP6	0360-0535	0		TERMINAL TEST POINT PCB	00000	ORDER BY DESCRIPTION
A37TP7	0360-0535	0		TERMINAL TEST POINT PCB	00000	ORDER BY DESCRIPTION
A37TP8	0360-0535	0		TERMINAL TEST POINT PCB	00000	ORDER BY DESCRIPTION
A37TP9	0360-0535	0		TERMINAL TEST POINT PCB	00000	ORDER BY DESCRIPTION
A37TP10	0360-0535	0		TERMINAL TEST POINT PCB	00000	ORDER BY DESCRIPTION
A37TP11	0360-0535	0		TERMINAL TEST POINT PCB	00000	ORDER BY DESCRIPTION
A37TP12	0360-0535	0		TERMINAL TEST POINT PCB	00000	ORDER BY DESCRIPTION
A37TP13	0360-0535	0		TERMINAL TEST POINT PCB	00000	ORDER BY DESCRIPTION
A37TP14	0360-0535	0		TERMINAL TEST POINT PCB	00000	ORDER BY DESCRIPTION
A37U1	1820-0909	9	2	IC MULTR TTL	01295	SN74167N
A37U2	1820-0909	9		IC MULTR TTL	01295	SN74167N
A37U3	1820-0808	7	1	IC GATE ECL NOR DUAL 3-INP	04713	MC10111P
A37U4	1820-1225	4	1	IC FF ECL D-M/S DUAL	04713	MC10231P
A37U5	1820-1320	0	1	IC RCVR ECL LINE RCVR TPL 2-INP	04713	MC10216L
A37U6	1810-0204	6	4	NETWORK-RES 8-SIP1.0K OHM X 7	01121	208A102
A37U7	1820-0802	1	1	IC GATE ECL NOR QUAD 2-INP	04713	MC10102P
A37U8	1810-0204	6		NETWORK-RES 8-SIP1.0K OHM X 7	01121	208A102
A37U9	1820-1196	8	2	IC FF TTL LS D-TYPE POS-EDGE-TRIG COM	01295	SN74LS174N
A37U10	1820-1196	8		IC FF TTL LS D-TYPE POS-EDGE-TRIG COM	01295	SN74LS174N
A37U11	1810-0204	6		NETWORK-RES 8-SIP1.0K OHM X 7	01121	208A102
A37U12	1820-0821	4	1	IC CNTR ECL BIN UP/DOWN SYNCHRO	04713	MC10136L
A37U13	1810-0204	6		NETWORK-RES 8-SIP1.0K OHM X 7	01121	208A102
A37U14	1820-0817	8	3	IC FF ECL D-M/S DUAL	04713	MC10131P
A37U15	1820-0817	8		IC FF ECL D-M/S DUAL	04713	MC10131P
A37U16	1820-0817	8		IC FF ECL D-M/S DUAL	04713	MC10131P
A37VR1	1902-3059	0	1	DIODE-ZNR 3.83V 5% DO-35 PD=.4W	28480	1902-3059
A37W1	08340-60107	7	1	CABLE ASSEMBLY- A37	28480	08340-60107

See introduction to this section for ordering information
 *Indicates factory selected value

Table 6-3. Model 8340A Replaceable Parts

Reference Designation	HP Part Number	C D	Qty	Description	Mfr Code	Mfr Part Number
A38	08340-60044	1	1	PLLI IF	28480	08340-60044
A38C1	0160-3878	6	5	CAPACITOR-FXD 1000PF +20% 100VDC CER	28480	0160-3878
A38C2	0160-0574	3	12	CAPACITOR-FXD .022UF ±20% 100VDC CER	28480	0160-0574
A38C3	0160-3878	6		CAPACITOR-FXD 1000PF ±20% 100VDC CER	28480	0160-3878
A38C4	0160-3878	6		CAPACITOR-FXD 1000PF ±20% 100VDC CER	28480	0160-3878
A38C5	0160-0574	3		CAPACITOR-FXD .022UF ±20% 100VDC CER	28480	0160-0574
A38C6	0160-3878	6		CAPACITOR-FXD 1000PF +20% 100VDC CER	28480	0160-3878
A38C7	0160-3875	3	4	CAPACITOR-FXD 22PF +5% 200VDC CER 0+30	28480	0160-3875
A38C8	0160-3875	3		CAPACITOR-FXD 22PF ±5% 200VDC CER 0+30	28480	0160-3875
A38C9	0160-3875	3		CAPACITOR-FXD 22PF ±5% 200VDC CER 0+30	28480	0160-3875
A38C10	0160-0574	3		CAPACITOR-FXD .022UF ±20% 100VDC CER	28480	0160-0574
A38C11	0160-0574	3		CAPACITOR-FXD .022UF +20% 100VDC CER	28480	0160-0574
A38C12	0160-0574	3		CAPACITOR-FXD .022UF ±20% 100VDC CER	28480	0160-0574
A38C13	0160-0574	3		CAPACITOR-FXD .022UF ±20% 100VDC CER	28480	0160-0574
A38C14	0160-3876	4	1	CAPACITOR-FXD 47PF +20% 200VDC CER	28480	0160-3876
A38C15	0160-0574	3		CAPACITOR-FXD .022UF ±20% 100VDC CER	28480	0160-0574
A38C16	0160-3653	5	1	CAPACITOR-FXD 33PF +5% 200VDC CER 0+30	28480	0160-3653
A38C17	0160-3878	6		CAPACITOR-FXD 1000PF +20% 100VDC CER	28480	0160-3878
A38C18	0160-3874	2		CAPACITOR-FXD 10PF +.5PF 200VDC CER	28480	0160-3874
A38C19	0160-0574	3		CAPACITOR-FXD .022UF +20% 100VDC CER	28480	0160-0574
A38C20	0160-0574	3		CAPACITOR-FXD .022UF ±20% 100VDC CER	28480	0160-0574
A38C21	0160-0574	3		CAPACITOR-FXD .022UF +20% 100VDC CER	28480	0160-0574
A38C22	0160-0574	3		CAPACITOR-FXD .022UF ±20% 100VDC CER	28480	0160-0574
A38C23	0160-3874	2		CAPACITOR-FXD 10PF +.5PF 200VDC CER	28480	0160-3874
A38C24	0160-3875	3		CAPACITOR-FXD 22PF ±5% 200VDC CER 0+30	28480	0160-3875
A38C25	0160-3565	8	3	CAPACITOR-FXD 6.8PF +.5PF 100VDC CER	28480	0160-3565
A38C26*	0160-3874	2	4	CAPACITOR-FXD 10PF +.5PF 200VDC CER	28480	0160-3874
A38C27	0160-3565	8		CAPACITOR-FXD 6.8PF +.5PF 100VDC CER	28480	0160-3565
A38C28	0160-0574	3		CAPACITOR-FXD .022UF +20% 100VDC CER	28480	0160-0574
A38C29	0160-3874	2		CAPACITOR-FXD 10PF +.5PF 200VDC CER	28480	0160-3874
A38C30	0160-3565	8		CAPACITOR-FXD 6.8PF +.5PF 100VDC CER	28480	0160-3565
A38C31	0160-3873	1	1	CAPACITOR-FXD 4.7PF +.5PF 200VDC CER	28480	0160-3873
A38C32	0160-4289	5	1	CAPACITOR-FXD 15PF ±5% 100VDC CER 0+30	51642	150100C0G150J
A38CR1	1901-0535	9	2	DIODE-SM SIG SCHOTTKY	28480	1901-0535
A38CR2	1901-0535	9		DIODE-SM SIG SCHOTTKY	28480	1901-0535
A38J1	1250-0690	6	1	CONNECTOR-RF MALE SMB	28480	1250-0690
A38L1	9100-2256	4	3	INDUCTOR RF-CH-MLD 560NH 10% .105DX.26LG	28480	9100-2256
A38L2	9100-2247	4	5	INDUCTOR RF-CH-MLD 100NH 10% .105DX.26LG	28480	9100-2247
A38L3	9100-2248	5	3	INDUCTOR RF-CH-MLD 120NH 10% .105DX.26LG	28480	9100-2248
A38L4	9100-2248	5		INDUCTOR RF-CH-MLD 120NH 10% .105DX.26LG	28480	9100-2248
A38L5	9100-2891	4	3	INDUCTOR RF-CH-MLD 50NH 10% .105DX.26LG	28480	9100-2891
A38L6	9100-2247	4		INDUCTOR RF-CH-MLD 100NH 10% .105DX.26LG	28480	9100-2247
A38L7	9100-2247	4		INDUCTOR RF-CH-MLD 100NH 10% .105DX.26LG	28480	9100-2247
A38L8	9100-1788	6	2	CHOKE-WIDE BAND ZMAX=680 OHM@ 180 MHZ	02114	VK200 20/48
A38L9	9100-1788	6		CHOKE-WIDE BAND ZMAX=680 OHM@ 180 MHZ	02114	VK200 20/48
A38L10	9100-0368	6	1	INDUCTOR RF-CH-MLD 330NH 10% .105DX.26LG	28480	9100-0368
A38L11	85660-80006	6	2	INDUCTOR- 120 NH	28480	85660-80006
A38L12	85660-80009	9	1	INDUCTOR- 100 NH	28480	85660-80009
A38L13	85660-80006	6		INDUCTOR- 120 NH	28480	85660-80006
A38L14	9100-2251	0	1	INDUCTOR RF-CH-MLD 220NH 10% .105DX.26LG	28480	9100-2251
A38L15	9100-2247	4		INDUCTOR RF-CH-MLD 100NH 10% .105DX.26LG	28480	9100-2247
A38L16	9100-2247	4		INDUCTOR RF-CH-MLD 100NH 10% .105DX.26LG	28480	9100-2247
A38L17	9100-2248	5		INDUCTOR RF-CH-MLD 120NH 10% .105DX.26LG	28480	9100-2248
A38L18	9100-2256	5		INDUCTOR RF-CH-MLD 560NH 10% .105DX.26LG	28480	9100-2256
A38L19	9100-2256	5		INDUCTOR RF-CH-MLD 560NH 10% .105DX.26LG	28480	9100-2256
A38L20	9100-2891	4		INDUCTOR RF-CH-MLD 50NH 10% .105DX.26LG	28480	9100-2891
A38L21	9100-2891	4		INDUCTOR RF-CH-MLD 50NH 10% .105DX.26LG	28480	9100-2891
A38MP1				NOT ASSIGNED		
A38MP2	2190-0124	4	6	WASHER-LK INTL T NO. 10 .195-IN-ID	28480	2190-0124
A38MP3	2190-0124	4		WASHER-LK INTL T NO. 10 .195-IN-ID	28480	2190-0124
A38MP4	2190-0124	4		WASHER-LK INTL T NO. 10 .195-IN-ID	28480	2190-0124
A38MP5	2190-0124	4		WASHER-LK INTL T NO. 10 .195-IN-ID	28480	2190-0124
A38MP6	2190-0124	4		WASHER-LK INTL T NO. 10 .195-IN-ID	28480	2190-0124
A38MP7	2190-0124	4		WASHER-LK INTL T NO. 10 .195-IN-ID	28480	2190-0124
A38MP8	2200-0101	0	2	SCREW-MACH 4-40 .188-IN-LG PAN-HD-POZI	00000	ORDER BY DESCRIPTION
A38MP9	2200-0101	0		SCREW-MACH 4-40 .188-IN-LG PAN-HD-POZI	00000	ORDER BY DESCRIPTION
A38MP10	2950-0078	9	3	NUT-HEX-DBL-CHAM 10-32-THD .067-IN-THK	28480	2950-0078
A38MP11	2950-0078	9		NUT-HEX-DBL-CHAM 10-32-THD .067-IN-THK	28480	2950-0078
A38MP12	2950-0078	9		NUT-HEX-DBL-CHAM 10-32-THD .067-IN-THK	28480	2950-0078
A38MP13	08340-20084	5	1	COVER-PC PLLI IF	28480	08340-20084
A38MP14	85660-00038	6	2	SHIELDING CAN	28480	85660-00038

See introduction to this section for ordering information
 *Indicates factory selected value

Table 6-3. Model 8340A Replaceable Parts

Reference Designation	HP Part Number	C D	Qty	Description	Mfr Code	Mfr Part Number
A38MP15	85660-00038	6		SHIELDING CAN	28480	85660-00038
A38MP16	85660-00040	0	1	SHIELDING CAN	28480	85660-00040
A38MP17	85660-20068	4	3	GROUND LUG	28480	85660-20068
A38MP18	85660-20068	4		GROUND LUG	28480	85660-20068
A38MP19	85660-20068	4		GROUND LUG	28480	85660-20068
A38MP20	86701-40001	9	2	EXTRACTOR-PC BOARD	28480	86701-40001
A38MP21	86701-40001	9		EXTRACTOR-PC BOARD	28480	86701-40001
A38Q1	1854-0345	8	4	TRANSISTOR NPN 2N5179 SI TO-72 PD=200MW	04713	2N5179
A38Q2	1854-0378	7	1	TRANSISTOR NPN 2N5109 SI TO-39 PD=800MW	3L585	2N5109
A38Q3	1854-0345	8		TRANSISTOR NPN 2N5179 SI TO-72 PD=200MW	04713	2N5179
A38Q4	1854-0345	8		TRANSISTOR NPN 2N5179 SI TO-72 PD=200MW	04713	2N5179
A38Q5	1854-0345	8		TRANSISTOR NPN 2N5179 SI TO-72 PD=200MW	04713	2N5179
A38R1	0757-0394	0	3	RESISTOR 51.1 1% .125W F TC=0+100	24546	C4-1/8-T0-51R1-F
A38R2	0698-3152	8	2	RESISTOR 3.48K 1% .125W F TC=0+100	24546	C4-1/8-T0-3481-F
A38R3	0757-0421	4	1	RESISTOR 825 1% .125W F TC=0+100	24546	C4-1/8-T0-825R-F
A38R4	0757-0401	0	3	RESISTOR 100 1% .125W F TC=0+100	24546	C4-1/8-T0-101-F
A38R5	0698-3429	2	3	RESISTOR 19.6 1% .125W F TC=0+100	03888	PME55-1/8-T0-19R6-F
A38R6	0698-3438	3	1	RESISTOR 147 1% .125W F TC=0+100	24546	C4-1/8-T0-147R-F
A38R7	0698-3446	3	1	RESISTOR 383 1% .125W F TC=0+100	24546	C4-1/8-T0-383R-F
A38R8	0698-3440	7	2	RESISTOR 196 1% .125W F TC=0+100	24546	C4-1/8-T0-196R-F
A38R9	0757-0394	0		RESISTOR 51.1 1% .125W F TC=0+100	24546	C4-1/8-T0-51R1-F
A38R10	0757-0401	0		RESISTOR 100 1% .125W F TC=0+100	24546	C4-1/8-T0-101-F
A38R11	0757-0397	3	1	RESISTOR 68.1 1% .125W F TC=0+100	24546	C4-1/8-T0-68R1-F
A38R12	0757-0401	0		RESISTOR 100 1% .125W F TC=0+100	24546	C4-1/8-T0-101-F
A38R13	0757-0428	1	1	RESISTOR 1.62K 1% .125W F TC=0+100	24546	C4-1/8-T0-1621-F
A38R14	0698-3152	8		RESISTOR 3.48K 1% .125W F TC=0+100	24546	C4-1/8-T0-3481-F
A38R15	0757-0416	7	1	RESISTOR 511 1% .125W F TC=0+100	24546	C4-1/8-T0-511R-F
A38R16	0698-3444	1	2	RESISTOR 316 1% .125W F TC=0+100	24546	C4-1/8-T0-316R-F
A38R17	0757-0346	2	1	RESISTOR 10 1% .125W F TC=0+100	24546	C4-1/8-T0-10R0-F
A38R18	0698-3444	1		RESISTOR 316 1% .125W F TC=0+100	24546	C4-1/8-T0-316R-F
A38R19	0757-0394	0		RESISTOR 51.1 1% .125W F TC=0+100	24546	C4-1/8-T0-51R1-F
A38R20	0698-3429	2		RESISTOR 19.6 1% .125W F TC=0+100	03888	PME55-1/8-T0-19R6-F
A38R21	0757-0280	3	5	RESISTOR 1K 1% .125W F TC=0+100	24546	C4-1/8-T0-1001-F
A38R22	0757-0280	3		RESISTOR 1K 1% .125W F TC=0+100	24546	C4-1/8-T0-1001-F
A38R23	0757-0280	3		RESISTOR 1K 1% .125W F TC=0+100	24546	C4-1/8-T0-1001-F
A38R24	0698-3429	2		RESISTOR 19.6 1% .125W F TC=0+100	03888	PME55-1/8-T0-19R6-F
A38R25	0757-0280	3		RESISTOR 1K 1% .125W F TC=0+100	24546	C4-1/8-T0-1001-F
A38R26	0757-0280	3		RESISTOR 1K 1% .125W F TC=0+100	24546	C4-1/8-T0-1001-F
A38R27	0698-3440	7		RESISTOR 196 1% .125W F TC=0+100	24546	C4-1/8-T0-196R-F
A38U1	0955-0063	0	1	MIXER-DOUBLER 5-500 MH	28480	0955-0063
A38W1	08340-60108	8	1	CABLE ASSEMBLY- A38	28480	08340-60108
A38W2	08340-60113	5	1	CABLE ASSEMBLY- A38	28480	08340-60113

See introduction to this section for ordering information
 *Indicates factory selected value

Table 6-3. Replaceable Parts

Reference Designation	HP Part Number	C D	Qty	Description	Mfr Code	Mfr Part Number
A39	08340-60045	2	1	PLL3 UPCONVERTER	28480	08340-60045
A39C1	0160-0574	3	16	CAPACITOR-FXD .022UF +-20% 100VDC CER	28480	0160-0574
A39C2	0160-0572	1	2	CAPACITOR-FXD 2200PF +-20% 100VDC CER	28480	0160-0572
A39C3	0160-0572	1		CAPACITOR-FXD 2200PF +-20% 100VDC CER	28480	0160-0572
A39C4	0160-0574	3		CAPACITOR-FXD .022UF +-20% 100VDC CER	28480	0160-0574
A39C5	0160-4084	8	3	CAPACITOR-FXD .1UF +-20% 50VDC CER	28480	0160-4084
A39C6	0160-4084	8		CAPACITOR-FXD .1UF +-20% 50VDC CER	28480	0160-4084
A39C7	0180-0291	3	2	CAPACITOR-FXD 1UF+-10% 35VDC TA	56289	150D105X9035A2
A39C8	0160-0161	4	2	CAPACITOR-FXD .01UF +-10% 200VDC POLYE	28480	0160-0161
A39C9	0160-0161	4		CAPACITOR-FXD .01UF +-10% 200VDC POLYE	28480	0160-0161
A39C10	0160-0574	3		CAPACITOR-FXD .022UF +-20% 100VDC CER	28480	0160-0574
A39C11	0160-0574	3		CAPACITOR-FXD .022UF +-20% 100VDC CER	28480	0160-0574
A39C12	0180-0228	6	3	CAPACITOR-FXD 22UF+-10% 15VDC TA	56289	150D226X9015B2
A39C13	0180-0291	3		CAPACITOR-FXD 1UF+-10% 35VDC TA	56289	150D105X9035A2
A39C14	0160-0574	3		CAPACITOR-FXD .022UF +-20% 100VDC CER	28480	0160-0574
A39C15	0160-0574	3		CAPACITOR-FXD .022UF +-20% 100VDC CER	28480	0160-0574
A39C16	0160-0574	3		CAPACITOR-FXD .022UF +-20% 100VDC CER	28480	0160-0574
A39C17	0160-4084	8		CAPACITOR-FXD .1UF +-20% 50VDC CER	28480	0160-4084
A39C18	0160-3749	0	2	CAPACITOR-FXD 330PF +-10% 50VDC CER	28480	0160-3749
A39C19	0160-3877	5	3	CAPACITOR-FXD 100PF +-20% 200VDC CER	28480	0160-3877
A39C20	0160-3749	0		CAPACITOR-FXD 330PF +-10% 50VDC CER	28480	0160-3749
A39C21	0180-0228	6		CAPACITOR-FXD 22UF+-10% 15VDC TA	56289	150D226X9015B2
A39C22	0160-3876	4	1	CAPACITOR-FXD 47PF +-20% 200VDC CER	28480	0160-3876
A39C23	0180-0228	6		CAPACITOR-FXD 22UF+-10% 15VDC TA	56289	150D226X9015B2
A39C24	0160-3877	5		CAPACITOR-FXD 100PF +-20% 200VDC CER	28480	0160-3877
A39C25	0160-0571	0	2	CAPACITOR-FXD 470PF +-20% 100VDC CER	28480	0160-0571
A39C26	0160-3877	5		CAPACITOR-FXD 100PF +-20% 200VDC CER	28480	0160-3877
A39C27	0160-0574	3		CAPACITOR-FXD .022UF +-20% 100VDC CER	28480	0160-0574
A39C28	0160-0571	0		CAPACITOR-FXD 470PF +-20% 100VDC CER	28480	0160-0571
A39C29	0160-3878	6	1	CAPACITOR-FXD 1000PF +-20% 100VDC CER	28480	0160-3878
A39C30	0160-0574	3		CAPACITOR-FXD .022UF +-20% 100VDC CER	28480	0160-0574
A39C31	0160-0574	3		CAPACITOR-FXD .022UF +-20% 100VDC CER	28480	0160-0574
A39C32	0160-0574	3		CAPACITOR-FXD .022UF +-20% 100VDC CER	28480	0160-0574
A39C33	0160-3875	3	3	CAPACITOR-FXD 22PF +-5% 200VDC CER 0+-30	28480	0160-3875
A39C34	0160-0574	3		CAPACITOR-FXD .022UF +-20% 100VDC CER	28480	0160-0574
A39C35	0160-3872	0	2	CAPACITOR-FXD 2.2PF +-25PF 200VDC CER	28480	0160-3872
A39C36	0160-3872	0		CAPACITOR-FXD 2.2PF +-25PF 200VDC CER	28480	0160-3872
A39C37	0160-3565	8	1	CAPACITOR-FXD 6.8PF +-5PF 100VDC CER	28480	0160-3565
A39C38	0160-0574	3		CAPACITOR-FXD .022UF +-20% 100VDC CER	28480	0160-0574
A39C39	0160-3874	2	3	CAPACITOR-FXD 10PF +-5PF 200VDC CER	28480	0160-3874
A39C40	0160-0574	3		CAPACITOR-FXD .022UF +-20% 100VDC CER	28480	0160-0574
A39C41	0160-0574	3		CAPACITOR-FXD .022UF +-20% 100VDC CER	28480	0160-0574
A39C42	0160-0574	3	2	CAPACITOR-FXD .022UF +-20% 100VDC CER	28480	0160-0574
A39C43	0160-3873	1		CAPACITOR-FXD 4.7PF +-5PF 200VDC CER	28480	0160-3873
A39C44	0160-3875	3		CAPACITOR-FXD 22PF +-5% 200VDC CER 0+-30	28480	0160-3875
A39C45	0160-3874	2		CAPACITOR-FXD 10PF +-5PF 200VDC CER	28480	0160-3874
A39C46	0160-3874	2		CAPACITOR-FXD 10PF +-5PF 200VDC CER	28480	0160-3874
A39C47	0160-3873	1		CAPACITOR-FXD 4.7PF +-5PF 200VDC CER	28480	0160-3873
A39C48	0160-3875	3		CAPACITOR-FXD 22PF +-5% 200VDC CER 0+-30	28480	0160-3875
A39C49*	0160-4521	8	1	CAPACITOR-FXD 12PF +-5% 200VDC CER 0+-30	28480	0160-4521
A39C50	0121-0452	4	1	CAPACITOR-V TRMR-AIR 1.3-5.4PF 175V	74970	187-0103-028
A39CR1	1901-0050	3	4	DIODE-SWITCHING 80V 200MA 2NS DO-35	28480	1901-0050
A39CR2	1901-0050	3		DIODE-SWITCHING 80V 200MA 2NS DO-35	28480	1901-0050
A39CR3	0122-0085	1	1	DIODE-VVC 2.2PF 7% C3/C25-MIN=4.5	02032	SMV1288
A39CR4	1901-0050	3		DIODE-SWITCHING 80V 200MA 2NS DO-35	28480	1901-0050
A39CR5	1901-0050	3		DIODE-SWITCHING 80V 200MA 2NS DO-35	28480	1901-0050
A39DS1	1990-0485	5	1	LED-LAMP LUM-INT=800UCD IF=30MA-MAX	28480	5082-4984
A39J1	1250-0690	6	2	CONNECTOR-RF MALE SMB	28480	1250-0690
A39J2	1250-0690	6		CONNECTOR-RF MALE SMB	28480	1250-0690
A39J3	1250-1889	7	1	CONNECTOR-RF SMB M PC 50-OHM	28480	1250-1889
A39L1	9140-0179	1	2	INDUCTOR RF-CH-MLD 22UH 10% .166DX.385LG	28480	9140-0179
A39L2	9140-0179	1		INDUCTOR RF-CH-MLD 22UH 10% .166DX.385LG	28480	9140-0179
A39L3	9100-1788	6	2	CHOKE-WIDE BAND ZMAX=680 OHM@ 180 MHZ	02114	VK200 20/48
A39L4	9100-1788	6		CHOKE-WIDE BAND ZMAX=680 OHM@ 180 MHZ	02114	VK200 20/48
A39L5	9100-2258	7	7	INDUCTOR RF-CH-MLD 1.2UH 10% .105DX.26LG	28480	9100-2258
A39L6	9100-2258	7		INDUCTOR RF-CH-MLD 1.2UH 10% .105DX.26LG	28480	9100-2258
A39L7	9100-2258	7		INDUCTOR RF-CH-MLD 1.2UH 10% .105DX.26LG	28480	9100-2258
A39L8	9100-2257	6	1	INDUCTOR RF-CH-MLD 820NH 10% .105DX.26LG	28480	9100-2257
A39L9	9100-2254	3	1	INDUCTOR RF-CH-MLD 390NH 10% .105DX.26LG	28480	9100-2254
A39L10	9100-2258	7		INDUCTOR RF-CH-MLD 1.2UH 10% .105DX.26LG	28480	9100-2258
A39L11	85660-80006	6	3	INDUCTOR- 120 NH	28480	85660-80006
A39L12	9100-2255	4	1	INDUCTOR RF-CH-MLD 470NH 10% .105DX.26LG	28480	9100-2255

See introduction to this section for ordering information.

*Indicates factory selected value.

Table 6-3. Model 8340A Replaceable Parts

Reference Designation	HP Part Number	C D	Qty	Description	Mfr Code	Mfr Part Number
A39L13	9100-2258	7	2	INDUCTOR RF-CH-MLD 1.2UH 10% .105DX.26LG	28480	9100-2258
A39L14	9100-2258	7		INDUCTOR RF-CH-MLD 1.2UH 10% .105DX.26LG	28480	9100-2258
A39L15	9135-0073	3		INDUCTOR RF-CH-MLD 51NH 6% .102DX.26LG	28480	9135-0073
A39L16	85660-80006	6	1	INDUCTOR- 120 NH	28480	85660-80006
A39L17	85660-80006	6		INDUCTOR- 120 NH	28480	85660-80006
A39L18	9135-0073	3		INDUCTOR RF-CH-MLD 51NH 6% .102DX.26LG	28480	9135-0073
A39L19	9100-2258	7		INDUCTOR RF-CH-MLD 1.2UH 10% .105DX.26LG	28480	9100-2258
A39L20	9100-2251	0		INDUCTOR RF-CH-MLD 220NH 10% .105DX.26LG	28480	9100-2251
A39L21	9140-0158	6		INDUCTOR RF-CH-MLD 1UH 10% .105DX.26LG	28480	9140-0158
A39L22	9140-0144	0	INDUCTOR RF-CH-MLD 4.7UH 10% .105DX.26LG	28480	9140-0144	
A39MP1	1200-0172	4	5	INSULATOR-XSTR DAP-GL	28480	1200-0172
A39MP2	1200-0172	4		INSULATOR-XSTR DAP-GL	28480	1200-0172
A39MP3	1200-0172	4		INSULATOR-XSTR DAP-GL	28480	1200-0172
A39MP4	1200-0172	4		INSULATOR-XSTR DAP-GL	28480	1200-0172
A39MP5	1200-0172	4		INSULATOR-XSTR DAP-GL	28480	1200-0172
A39MP6	2190-0124	4	6	WASHER-LK INTL T NO. 10 .195-IN-ID	28480	2190-0124
A39MP7	2190-0124	4		WASHER-LK INTL T NO. 10 .195-IN-ID	28480	2190-0124
A39MP8	2190-0124	4		WASHER-LK INTL T NO. 10 .195-IN-ID	28480	2190-0124
A39MP9	2190-0124	4		WASHER-LK INTL T NO. 10 .195-IN-ID	28480	2190-0124
A39MP10	2190-0124	4		WASHER-LK INTL T NO. 10 .195-IN-ID	28480	2190-0124
A39MP11	2190-0124	4		WASHER-LK INTL T NO. 10 .195-IN-ID	28480	2190-0124
A39MP12	2200-0101	0	2	SCREW-MACH 4-40 .188-IN-LG PAN-HD-POZI	00000	ORDER BY DESCRIPTION
A39MP13	2200-0101	0		SCREW-MACH 4-40 .188-IN-LG PAN-HD-POZI	00000	ORDER BY DESCRIPTION
A39MP14	2950-0078	9	3	NUT-HEX-DBL-CHAM 10-32-THD .067-IN-THK	28480	2950-0078
A39MP15	2950-0078	9		NUT-HEX-DBL-CHAM 10-32-THD .067-IN-THK	28480	2950-0078
A39MP16	2950-0078	9	1	NUT-HEX-DBL-CHAM 10-32-THD .067-IN-THK	28480	2950-0078
A39MP17	08340-20085	6		COVER-PC PLL1 UPCONVERTER	28480	08340-20085
A39MP18	85660-00042	2	3	SHIELDING CAN	28480	85660-00042
A39MP19	85660-20068	4		GROUND LUG	28480	85660-20068
A39MP20	85660-20068	4	GROUND LUG	28480	85660-20068	
A39MP21	85660-20068	4	1	GROUND LUG	28480	85660-20068
A39MP22	86701-40001	9		EXTRACTOR-PC BOARD	28480	86701-40001
A39MP23	3050-0082	8		WASHER-FL NM NO. 4 .116-IN-ID .188-IN-OD	28480	3050-0082
A39Q1	1854-0345	8	4	TRANSISTOR NPN 2N5179 SI TO-72 PD=200MW	04713	2N5179
A39Q2	1854-0345	8		TRANSISTOR NPN 2N5179 SI TO-72 PD=200MW	04713	2N5179
A39Q3	1854-0345	8		TRANSISTOR NPN 2N5179 SI TO-72 PD=200MW	04713	2N5179
A39Q4	1854-0345	8		TRANSISTOR NPN 2N5179 SI TO-72 PD=200MW	04713	2N5179
A39Q5	1855-0327	8	1	TRANSISTOR J-FET 2N4416 N-CHAN D-MODE	01295	2N4416
A39R1	0698-3440	7	3	RESISTOR 196 1% .125W F TC=0+100	24546	C4-1/8-T0-196R-F
A39R2	0757-0394	0		RESISTOR 51.1 1% .125W F TC=0+100	24546	C4-1/8-T0-51R1-F
A39R3	0698-0083	8		RESISTOR 1.96K 1% .125W F TC=0+100	24546	C4-1/8-T0-1961-F
A39R4	0757-0418	9		RESISTOR 619 1% .125W F TC=0+100	24546	C4-1/8-T0-619R-F
A39R5	0757-0280	3		RESISTOR 1K 1% .125W F TC=0+100	24546	C4-1/8-T0-1001-F
A39R6	0757-0280	3	2	RESISTOR 1K 1% .125W F TC=0+100	24546	C4-1/8-T0-1001-F
A39R7	0698-3159	5		RESISTOR 26.1K 1% .125W F TC=0+100	24546	C4-1/8-T0-2612-F
A39R8	0698-3159	5		RESISTOR 26.1K 1% .125W F TC=0+100	24546	C4-1/8-T0-2612-F
A39R9	0757-0280	3		RESISTOR 1K 1% .125W F TC=0+100	24546	C4-1/8-T0-1001-F
A39R10	0757-0280	3		RESISTOR 1K 1% .125W F TC=0+100	24546	C4-1/8-T0-1001-F
A39R11	0757-0438	3		3	RESISTOR 5.11K 1% .125W F TC=0+100	24546
A39R12	0757-0441	8	RESISTOR 8.25K 1% .125W F TC=0+100		24546	C4-1/8-T0-8251-F
A39R13	0757-0438	3	RESISTOR 5.11K 1% .125W F TC=0+100		24546	C4-1/8-T0-5111-F
A39R14	0698-3160	8	1	RESISTOR 31.6K 1% .125W F TC=0+100	24546	C4-1/8-T0-3162-F
A39R15	0698-3447	4		RESISTOR 422 1% .125W F TC=0+100	24546	C4-1/8-T0-422R-F
A39R16	0757-0441	8	4	RESISTOR 8.25K 1% .125W F TC=0+100	24546	C4-1/8-T0-8251-F
A39R17	0757-0441	8		RESISTOR 8.25K 1% .125W F TC=0+100	24546	C4-1/8-T0-8251-F
A39R18	0757-0438	3		RESISTOR 5.11K 1% .125W F TC=0+100	24546	C4-1/8-T0-5111-F
A39R19	0757-0346	2		RESISTOR 10 1% .125W F TC=0+100	24546	C4-1/8-T0-10R0-F
A39R20	0757-0346	2		RESISTOR 10 1% .125W F TC=0+100	24546	C4-1/8-T0-10R0-F
A39R21	0757-0346	2		RESISTOR 10 1% .125W F TC=0+100	24546	C4-1/8-T0-10R0-F
A39R22	0757-0421	4	1	RESISTOR 825 1% .125W F TC=0+100	24546	C4-1/8-T0-825R-F
A39R23	0757-0466	7		RESISTOR 110K 1% .125W F TC=0+100	24546	C4-1/8-T0-1103-F
A39R24	0698-3156	2		RESISTOR 14.7K 1% .125W F TC=0+100	24546	C4-1/8-T0-1472-F
A39R25	0698-0083	8		RESISTOR 1.96K 1% .125W F TC=0+100	24546	C4-1/8-T0-1961-F
A39R26	0698-0083	8		RESISTOR 1.96K 1% .125W F TC=0+100	24546	C4-1/8-T0-1961-F
A39R27	0698-3440	7	2	RESISTOR 196 1% .125W F TC=0+100	24546	C4-1/8-T0-196R-F
A39R28	0757-0346	2		RESISTOR 10 1% .125W F TC=0+100	24546	C4-1/8-T0-10R0-F
A39R29	0757-0397	3		RESISTOR 68.1 1% .125W F TC=0+100	24546	C4-1/8-T0-68R1-F
A39R30	0757-0280	3		RESISTOR 1K 1% .125W F TC=0+100	24546	C4-1/8-T0-1001-F
A39R31	0698-3156	2		RESISTOR 14.7K 1% .125W F TC=0+100	24546	C4-1/8-T0-1472-F
A39R32	0698-7219	6	1	RESISTOR 196 1% .05W F TC=0+100	24546	C3-1/8-T0-196R-F
A39R33	0757-0397	3		RESISTOR 68.1 1% .125W F TC=0+100	24546	C4-1/8-T0-68R1-F
A39R34	0698-3440	7		RESISTOR 196 1% .125W F TC=0+100	24546	C4-1/8-T0-196R-F
A39R35	0757-0394	0		RESISTOR 51.1 1% .125W F TC=0+100	24546	C4-1/8-T0-51R1-F

See introduction to this section for ordering information
 *Indicates factory selected value

Table 6-3. Model 8340A Replaceable Parts

Reference Designation	HP Part Number	C D	Qty	Description	Mfr Code	Mfr Part Number
A39R36	0757-0279	0	1	RESISTOR 3.16K 1% .125W F TC=0+100	24546	C4-1/8-T0-3161-F
A39R37	0757-1094	9	1	RESISTOR 1.47K 1% .125W F TC=0+100	24546	C4-1/8-T0-1471-F
A39R38	0698-7192	4	1	RESISTOR 14.7 1% .05W F TC=0+100	24546	C3-1/8-T0-14R7-F
A39R39	0698-7230	1	2	RESISTOR 562 1% .05W F TC=0+100	24546	C3-1/8-T0-562R-F
A39R40	0698-7188	8	1	RESISTOR 10 1% .05W F TC=0+100	24546	C3-1/8-T0-10R-F
A39R41	0698-7200	5	2	RESISTOR 31.6 1% .05W F TC=0+100	24546	C3-1/8-T0-31R6-F
A39R42	0698-7236	7	2	RESISTOR 1K 1% .05W F TC=0+100	24546	C3-1/8-T0-1001-F
A39R43	0698-7248	1	1	RESISTOR 3.16K 1% .05W F TC=0+100	24546	C3-1/8-T0-3161-F
A39R44	0698-7236	7	7	RESISTOR 1K 1% .05W F TC=0+100	24546	C3-1/8-T0-1001-F
A39R45	0698-7230	1	1	RESISTOR 562 1% .05W F TC=0+100	24546	C3-1/8-T0-562R-F
A39R46	0698-7218	5	2	RESISTOR 17R 1% .05W F TC=0+100	24546	C3-1/8-T0-17R-F
A39R47	0698-7200	5	5	RESISTOR 31.6 1% .05W F TC=0+100	24546	C3-1/8-T0-31R6-F
A39R48	0698-7218	5	5	RESISTOR 17R 1% .05W F TC=0+100	24546	C3-1/8-T0-17R-F
A39R49	0698-7207	2	1	RESISTOR 61.9 1% .05W F TC=0+100	24546	C3-1/8-T0-61R9-F
A39TP1	0360-0535	0	3	TERMINAL TEST POINT PCB	00000	ORDER BY DESCRIPTION
A39TP2	0360-0535	0		TERMINAL TEST POINT PCB	00000	ORDER BY DESCRIPTION
A39TP3	0360-0535	0		TERMINAL TEST POINT PCB	00000	ORDER BY DESCRIPTION
A39U1	1826-0092	3	1	IC OP AMP GP DUAL TO-99 PKG	28480	1826-0092
A39U2	1826-0261	8	1	IC OP AMP LOW-NOISE TO-99 PKG	28480	1826-0261
A39U3	1820-1383	5	1	IC CNTR ECL BCD POS-EDGE-TRIG	04713	MC10138L
A39U4	1810-0205	7	1	NETWORK-RES 8-SIP4.7K OHM X 7	01121	208A472
A39U5	1820-0817	8	1	IC FF ECL D-M/S DUAL	04713	MC10131P
A39U6	1820-0802	1	1	IC GATE ECL NOR QUAD 2-INP	04713	MC10102P
A39U7	0955-0063	0	1		28480	0955-0063
A39W1	08340-60109	9	1	CABLE ASSEMBLY- A39	28480	08340-60109

See introduction to this section for ordering information
 *Indicates factory selected value

Table 6-3. Replaceable Parts

Reference Designation	HP Part Number	C D	Qty	Description	Mfr Code	Mfr Part Number
A40	0B340-60046	3	1	PLL2 VCO	2B480	0B340-60046
A40C1	0160-0300	3	1	CAPACITOR-FXD 2700PF +-10% 200VDC POLYE	2B480	0160-0300
A40C2	0160-0155	6	1	CAPACITOR-FXD 3300PF +-10% 200VDC POLYE	2B480	0160-0155
A40C3	0160-0154	5	1	CAPACITOR-FXD 2200PF +-10% 200VDC POLYE	2B480	0160-0154
A40C4	0160-3B79	7	4	CAPACITOR-FXD .01UF +-20% 100VDC CER	2B480	0160-3B79
A40C5	0160-40B4	8	14	CAPACITOR-FXD .1UF +-20% 50VDC CER	2B480	0160-40B4
A40C6	0160-3B79	7		CAPACITOR-FXD .01UF +-20% 100VDC CER	2B480	0160-3B79
A40C7	0160-3B79	7		CAPACITOR-FXD .01UF +-20% 100VDC CER	2B480	0160-3B79
A40C8	0160-3B7B	6	6	CAPACITOR-FXD 1000PF +-20% 100VDC CER	2B480	0160-3B7B
A40C9	0160-40B4	8		CAPACITOR-FXD .1UF +-20% 50VDC CER	2B480	0160-40B4
A40C10	0160-3B7B	6		CAPACITOR-FXD 1000PF +-20% 100VDC CER	2B480	0160-3B7B
A40C11	0160-3B7B	6		CAPACITOR-FXD 1000PF +-20% 100VDC CER	2B480	0160-3B7B
A40C12	0160-4525	2	1	CAPACITOR-FXD 29PF +-5% 200VDC CER 0+-30	2B480	0160-4525
A40C13	0160-4524	1	1	CAPACITOR-FXD 24PF +-5% 200VDC CER 0+-30	51642	200-200-NP0-240J
A40C14	0160-3B79	7		CAPACITOR-FXD .01UF +-20% 100VDC CER	2B480	0160-3B79
A40C15	0160-3B7B	6		CAPACITOR-FXD 1000PF +-20% 100VDC CER	2B480	0160-3B7B
A40C16	0160-3B7B	6		CAPACITOR-FXD 1000PF +-20% 100VDC CER	2B480	0160-3B7B
A40C17	0160-3B7B	6		CAPACITOR-FXD 1000PF +-20% 100VDC CER	2B480	0160-3B7B
A40C18	0160-40B4	8		CAPACITOR-FXD .1UF +-20% 50VDC CER	2B480	0160-40B4
A40C19	0160-0127	2	1	CAPACITOR-FXD .1UF +-20% 25VDC CER	2B480	0160-0127
A40C20	0160-40B4	8		CAPACITOR-FXD .1UF +-20% 50VDC CER	2B480	0160-40B4
A40C21	0160-0571	0	1	CAPACITOR-FXD 470PF +-20% 100VDC CER	2B480	0160-0571
A40C22	0160-40B4	8		CAPACITOR-FXD .1UF +-20% 50VDC CER	2B480	0160-40B4
A40C23	0160-40B4	8		CAPACITOR-FXD .1UF +-20% 50VDC CER	2B480	0160-40B4
A40C24	0160-40B4	8		CAPACITOR-FXD .1UF +-20% 50VDC CER	2B480	0160-40B4
A40C25	0160-3B77	5	1	CAPACITOR-FXD 100PF +-20% 200VDC CER	2B480	0160-3B77
A40C26	0160-40B4	8		CAPACITOR-FXD .1UF +-20% 50VDC CER	2B480	0160-40B4
A40C27	0160-40B4	8		CAPACITOR-FXD .1UF +-20% 50VDC CER	2B480	0160-40B4
A40C28	0160-40B4	8		CAPACITOR-FXD .1UF +-20% 50VDC CER	2B480	0160-40B4
A40C29	0180-2141	6	2	CAPACITOR-FXD 3.3UF +-10% 50VDC TA	56289	150D335X9050B2
A40C30	0180-2141	6		CAPACITOR-FXD 3.3UF +-10% 50VDC TA	56289	150D335X9050B2
A40C31	0180-1715	8	1	CAPACITOR-FXD 150UF +-10% 6VDC TA	56289	150D157X9006R2
A40C32	0180-1746	5	2	CAPACITOR-FXD 15UF +-10% 20VDC TA	56289	150D156X9020B2
A40C33	0160-40B4	8		CAPACITOR-FXD .1UF +-20% 50VDC CER	2B480	0160-40B4
A40C34	0180-0229	7	1	CAPACITOR-FXD 33UF +-10% 10VDC TA	56289	150D336X9010B2
A40C35	0160-40B4	8		CAPACITOR-FXD .1UF +-20% 50VDC CER	2B480	0160-40B4
A40C36	0180-1746	5		CAPACITOR-FXD 15UF +-10% 20VDC TA	56289	150D156X9020B2
A40C37	0160-40B4	8		CAPACITOR-FXD .1UF +-20% 50VDC CER	2B480	0160-40B4
A40C38	0160-40B4	8		CAPACITOR-FXD .1UF +-20% 50VDC CER	2B480	0160-40B4
A40CR1	0122-00B5	1	4	DIODE-VVC 2.2PF 7% C3/C25-MIN=4.5	02032	SMV1268
A40CR2	0122-00B5	1		DIODE-VVC 2.2PF 7% C3/C25-MIN=4.5	02032	SMV1268
A40CR3	0122-00B5	1		DIODE-VVC 2.2PF 7% C3/C25-MIN=4.5	02032	SMV1268
A40CR4	0122-00B5	1		DIODE-VVC 2.2PF 7% C3/C25-MIN=4.5	02032	SMV1268
A40J1	1250-0544	9	5	CONNECTOR-RF MALE SMB	2B480	1250-0544
A40J2	1250-0544	9		CONNECTOR-RF MALE SMB	2B480	1250-0544
A40J3	1250-0544	9		CONNECTOR-RF MALE SMB	2B480	1250-0544
A40J4	1250-0544	9		CONNECTOR-RF MALE SMB	2B480	1250-0544
A40J5	1250-0544	9		CONNECTOR-RF MALE SMB	2B480	1250-0544
A40L1	85660-80031	7	2	INDUCTOR	2B480	85660-80031
A40L2	85660-00031	7		INDUCTOR	2B480	85660-00031
A40L3	9140-0144	0	1	INDUCTOR RF-CH-MLD 4.7UH 10% .105DX.26LG	2B480	9140-0144
A40L4	9100-3358	0	2	INDUCTOR RF-CH-MLD 162NH 5% .2DX.385LG	2B480	9100-3358
A40L5	9100-3358	0		INDUCTOR RF-CH-MLD 162NH 5% .2DX.385LG	2B480	9100-3358
A40L6	9100-2251	0	1	INDUCTOR RF-CH-MLD 220NH 10% .105DX.26LG	2B480	9100-2251
A40L7	9140-0158	6	2	INDUCTOR RF-CH-MLD 1UH 10% .105DX.26LG	2B480	9140-0158
A40L8	9100-2247	4	8	INDUCTOR RF-CH-MLD 100NH 10% .105DX.26LG	2B480	9100-2247
A40L9	9100-2891	4	2	INDUCTOR RF-CH-MLD 50NH 10% .105DX.26LG	2B480	9100-2891
A40L10	9100-2891	4		INDUCTOR RF-CH-MLD 50NH 10% .105DX.26LG	2B480	9100-2891
A40L11	9140-0158	6		INDUCTOR RF-CH-MLD 1UH 10% .105DX.26LG	2B480	9140-0158
A40L12	9100-2247	4		INDUCTOR RF-CH-MLD 100NH 10% .105DX.26LG	2B480	9100-2247
A40L13	9100-2258	7	1	INDUCTOR RF-CH-MLD 1.2UH 10% .105DX.26LG	2B480	9100-2258
A40L14	9100-2250	9	1	INDUCTOR RF-CH-MLD 180NH 10% .105DX.26LG	2B480	9100-2250
A40L15	9100-2247	4		INDUCTOR RF-CH-MLD 100NH 10% .105DX.26LG	2B480	9100-2247
A40L16	9100-2247	4		INDUCTOR RF-CH-MLD 100NH 10% .105DX.26LG	2B480	9100-2247
A40L17	9100-2247	4		INDUCTOR RF-CH-MLD 100NH 10% .105DX.26LG	2B480	9100-2247
A40L18	9100-2247	4		INDUCTOR RF-CH-MLD 100NH 10% .105DX.26LG	2B480	9100-2247
A40L19	9100-2247	4		INDUCTOR RF-CH-MLD 100NH 10% .105DX.26LG	2B480	9100-2247
A40L20	9100-2247	4		INDUCTOR RF-CH-MLD 100NH 10% .105DX.26LG	2B480	9100-2247
A40L21	9100-1618	1	3	INDUCTOR RF-CH-MLD 5.6UH 10%	2B480	9100-1618
A40L22	9100-1618	1		INDUCTOR RF-CH-MLD 5.6UH 10%	2B480	9100-1618
A40L23	9100-1618	1		INDUCTOR RF-CH-MLD 5.6UH 10%	2B480	9100-1618
A40MPI	1200-0172	4	4	INSULATOR-XSTR DAP-GL	2B480	1200-0172

See introduction to this section for ordering information.

*Indicates factory selected value.

Table 6-3. Model 8340A Replaceable Parts

Reference Designation	HP Part Number	C D	Qty	Description	Mfr Code	Mfr Part Number
A40MP2	1200-0172	4		INSULATOR-XSTR DAP-GL	28480	1200-0172
A40MP3	1200-0172	4		INSULATOR-XSTR DAP-GL	28480	1200-0172
A40MP4	1200-0172	4		INSULATOR-XSTR DAP-GL	28480	1200-0172
A40MP5	2190-0124	4	1	WASHER-LK INTL T NO. 10 .195-IN-ID	28480	2190-0124
A40MP6	2200-0101	0	2	SCREW-MACH 4-40 .188-IN-LG PAN-HD-POZI	00000	ORDER BY DESCRIPTION
A40MP7	2200-0101	0		SCREW-MACH 4-40 .188-IN-LG PAN-HD-POZI	00000	ORDER BY DESCRIPTION
A40MP8	2950-0078	9	1	NUT-HEX-DBL-CHAM 10-32-THD .067-IN-THK	28480	2950-0078
A40MP9	08340-20086	7	1	COVER-PC PLI.2 VCO	28480	08340-20086
A40MP10	86701-40001	9	2	EXTRACTOR-PC BOARD	28480	86701-40001
A40MP11	86701-40001	9		EXTRACTOR-PC BOARD	28480	86701-40001
A40Q1	1854-0610	0	2	TRANSISTOR NPN SI TO-46 FT=800MHZ	28480	1854-0610
A40Q2	1854-0610	0		TRANSISTOR NPN SI TO-46 FT=800MHZ	28480	1854-0610
A40Q3	1854-0345	8	2	TRANSISTOR NPN 2N5179 SI TO-72 PD=200MW	04713	2N5179
A40Q4	1854-0345	8		TRANSISTOR NPN 2N5179 SI TO-72 PD=200MW	04713	2N5179
A40Q5	1853-0281	9	2	TRANSISTOR PNP 2N2907A SI TO-18 PD=400MW	04713	2N2907A
A40Q6	1853-0281	9		TRANSISTOR PNP 2N2907A SI TO-18 PD=400MW	04713	2N2907A
A40R1	0698-0085	0	1	RESISTOR 2.61K 1% .125W F TC=0+100	24546	C4-1/8-T0-2611-F
A40R2	2100-3273	1	2	RESISTOR-TRMR 2K 10% C SIDE-ADJ 1-TRN	28480	2100-3273
A40R3	0757-0428	1	1	RESISTOR 1.62K 1% .125W F TC=0+100	24546	C4-1/8-T0-1621-F
A40R4	2100-3273	1		RESISTOR-TRMR 2K 10% C SIDE-ADJ 1-TRN	28480	2100-3273
A40R5	0757-0447	4	1	RESISTOR 16.2K 1% .125W F TC=0+100	24546	C4-1/8-T0-1622-F
A40R6	0757-0401	0	3	RESISTOR 100 1% .125W F TC=0+100	24546	C4-1/8-T0-101-F
A40R7	0698-7205	0	2	RESISTOR 51.1 1% .05W F TC=0+100	24546	C3-1/8-T0-51R1-F
A40R8	0698-7205	0		RESISTOR 51.1 1% .05W F TC=0+100	24546	C3-1/8-T0-51R1-F
A40R9	0757-0346	2	4	RESISTOR 10 1% .125W F TC=0+100	24546	C4-1/8-T0-10R0-F
A40R10	0698-7228	7	2	RESISTOR 464 1% .05W F TC=0+100	24546	C3-1/8-T0-464R-F
A40R11	0698-7228	7		RESISTOR 464 1% .05W F TC=0+100	24546	C3-1/8-T0-464R-F
A40R12	0698-7188	8	1	RESISTOR 10 1% .05W F TC=0+100	24546	C3-1/8-T0-10R-F
A40R13	0757-0346	2		RESISTOR 10 1% .125W F TC=0+100	24546	C4-1/8-T0-10R0-F
A40R14	0757-0398	4	4	RESISTOR 75 1% .125W F TC=0+100	24546	C4-1/8-T0-75R0-F
A40R15	0757-0398	4		RESISTOR 75 1% .125W F TC=0+100	24546	C4-1/8-T0-75R0-F
A40R16	0757-0418	9	1	RESISTOR 619 1% .125W F TC=0+100	24546	C4-1/8-T0-619R-F
A40R17	0757-0346	2		RESISTOR 10 1% .125W F TC=0+100	24546	C4-1/8-T0-10R0-F
A40R18	0757-0419	0	3	RESISTOR 681 1% .125W F TC=0+100	24546	C4-1/8-T0-681R-F
A40R19	0757-0346	2		RESISTOR 10 1% .125W F TC=0+100	24546	C4-1/8-T0-10R0-F
A40R20	0757-0400	9	1	RESISTOR 90.9 1% .125W F TC=0+100	24546	C4-1/8-T0-90R9-F
A40R21	0757-0398	4		RESISTOR 75 1% .125W F TC=0+100	24546	C4-1/8-T0-75R0-F
A40R22	0757-0398	4		RESISTOR 75 1% .125W F TC=0+100	24546	C4-1/8-T0-75R0-F
A40R23	0757-0401	0		RESISTOR 100 1% .125W F TC=0+100	24546	C4-1/8-T0-101-F
A40R24	0698-4037	0	1	RESISTOR 46.4 1% .125W F TC=0+100	24546	C4-1/8-T0-46R4-F
A40R25	0698-0083	8	1	RESISTOR 1.96K 1% .125W F TC=0+100	24546	C4-1/8-T0-1961-F
A40R26	0757-0280	3	5	RESISTOR 1K 1% .125W F TC=0+100	24546	C4-1/8-T0-1001-F
A40R27	0698-3440	7	1	RESISTOR 196 1% .125W F TC=0+100	24546	C4-1/8-T0-196R-F
A40R28	0757-0280	3		RESISTOR 1K 1% .125W F TC=0+100	24546	C4-1/8-T0-1001-F
A40R29	0757-0316	6	1	RESISTOR 42.2 1% .125W F TC=0+100	24546	C4-1/8-T0-42R2-F
A40R30	0757-0280	3		RESISTOR 1K 1% .125W F TC=0+100	24546	C4-1/8-T0-1001-F
A40R31	0757-0280	3		RESISTOR 1K 1% .125W F TC=0+100	24546	C4-1/8-T0-1001-F
A40R32	0698-3446	3	1	RESISTOR 383 1% .125W F TC=0+100	24546	C4-1/8-T0-383R-F
A40R33	0698-3444	1	2	RESISTOR 316 1% .125W F TC=0+100	24546	C4-1/8-T0-316R-F
A40R34	0757-0419	0		RESISTOR 681 1% .125W F TC=0+100	24546	C4-1/8-T0-681R-F
A40R35	0698-3444	1		RESISTOR 316 1% .125W F TC=0+100	24546	C4-1/8-T0-316R-F
A40R36	0757-0419	0		RESISTOR 681 1% .125W F TC=0+100	24546	C4-1/8-T0-681R-F
A40R37	0757-0442	9	2	RESISTOR 10K 1% .125W F TC=0+100	24546	C4-1/8-T0-1002-F
A40R38	0757-0442	9		RESISTOR 10K 1% .125W F TC=0+100	24546	C4-1/8-T0-1002-F
A40R39	0757-0465	6	1	RESISTOR 100K 1% .125W F TC=0+100	24546	C4-1/8-T0-1003-F
A40R40	0757-0280	3		RESISTOR 1K 1% .125W F TC=0+100	24546	C4-1/8-T0-1001-F
A40R41	0757-0401	0		RESISTOR 100 1% .125W F TC=0+100	24546	C4-1/8-T0-101-F
A40R42	0757-0397	3	1	RESISTOR 68.1 1% .125W F TC=0+100	24546	C4-1/8-T0-68R1-F
A40R43	0698-3132	4	1	RESISTOR 261 1% .125W F TC=0+100	24546	C4-1/8-T0-2610-F
A40R44	0757-0416	7	1	RESISTOR 511 1% .125W F TC=0+100	24546	C4-1/8-T0-511R-F
A40T1	08553-6012	5	1	TRANSFORMER-RF (BLUE)	28480	08553-6012
A40TP1	0360-0535	0	1	TERMINAL TEST POINT PCB	00000	ORDER BY DESCRIPTION
A40U1	1820-1383	5	2	IC CNTR ECL BCD POS-EDGE-TRIG	04713	MC10138L
A40U2	1820-1383	5		IC CNTR ECL BCD POS-EDGE-TRIG	04713	MC10138L
A40U3	1820-2047	0	1	IC DIVR ECL QUINARY	52648	SP8622BDG
A40U4	1810-0205	7	1	NETWORK-RES 8-SIP4.7K OHM X 7	01121	208A472
A40U5	1820-0802	1	3	IC GATE ECL NOR QUAD 2-INP	04713	MC10102P
A40U6	1820-0802	1		IC GATE ECL NOR QUAD 2-INP	04713	MC10102P
A40U7	1820-0802	1		IC GATE ECL NOR QUAD 2-INP	04713	MC10102P
A40W1	08340-60110	2	1	CABLE ASSEMBLY- A40	28480	08340-60110

See introduction to this section for ordering information
 *Indicates factory selected value

Table 6-3. Model 8340A Replaceable Parts

Reference Designation	HP Part Number	C D	Qty	Description	Mfr Code	Mfr Part Number
A41	08340-60162	4	1	PLL2 PHASE DETECTOR	28480	08340-60162
A41C1	0180-0197	8	4	CAPACITOR-FXD 2.2UF+10% 20VDC TA	56289	150D225X9020A2
A41C2	0160-0574	3	1	CAPACITOR-FXD .022UF +20% 100VDC CER	28480	0160-0574
A41C3	0160-3879	7	3	CAPACITOR-FXD .01UF +20% 100VDC CER	28480	0160-3879
A41C4	0160-0127	2	2	CAPACITOR-FXD 1UF +20% 25VDC CER	28480	0160-0127
A41C5	0160-0127	2		CAPACITOR-FXD 1UF +20% 25VDC CER	28480	0160-0127
A41C6				NOT ASSIGNED		
A41C7	0160-5609	5	1	CAPACITOR- MPC 10.0 UF 50VDC	28480	0160-5609
A41C8	0160-4084	8	4	CAPACITOR-FXD .1UF +20% 50VDC CER	28480	0160-4084
A41C9	0160-0573	2	1	CAPACITOR-FXD 4700PF +20% 100VDC CER	28480	0160-0573
A41C10	0160-2199	2	1	CAPACITOR-FXD 30PF +5% 300VDC MICA	28480	0160-2199
A41C11	0180-0291	3	3	CAPACITOR-FXD 1UF+10% 35VDC TA	56289	150D105X9035A2
A41C12	0180-0291	3		CAPACITOR-FXD 1UF+10% 35VDC TA	56289	150D105X9035A2
A41C13	0160-4535	4	1	CAPACITOR-FXD 1UF +10% 50VDC CER	28480	0160-4535
A41C14	0160-3879	7		CAPACITOR-FXD .01UF +20% 100VDC CER	28480	0160-3879
A41C15	0160-3879	7		CAPACITOR-FXD .01UF +20% 100VDC CER	28480	0160-3879
A41C16	0160-4084	8		CAPACITOR-FXD .1UF +20% 50VDC CER	28480	0160-4084
A41C17	0180-0291	3		CAPACITOR-FXD 1UF+10% 35VDC TA	56289	150D105X9035A2
A41C18	0160-4084	8		CAPACITOR-FXD .1UF +20% 50VDC CER	28480	0160-4084
A41C19	0180-0197	8		CAPACITOR-FXD 2.2UF+10% 20VDC TA	56289	150D225X9020A2
A41C20	0160-4084	8		CAPACITOR-FXD .1UF +20% 50VDC CER	28480	0160-4084
A41C21	0180-0197	8		CAPACITOR-FXD 2.2UF+10% 20VDC TA	56289	150D225X9020A2
A41C22	0180-0197	8		CAPACITOR-FXD 2.2UF+10% 20VDC TA	56289	150D225X9020A2
A41C23	0160-2437	1	2	CAPACITOR-FDTHRU 5000PF +80 -20% 200V	28480	0160-2437
A41C24	0160-2437	1		CAPACITOR-FDTHRU 5000PF +80 -20% 200V	28480	0160-2437
A41CR1	1901-0033	2	2	DIODE-GEN PRP 180V 200MA DO-7	28480	1901-0033
A41CR2	1901-0376	6	2	DIODE-GEN PRP 35V 50MA DO-35	28480	1901-0376
A41CR3	1901-0376	6		DIODE-GEN PRP 35V 50MA DO-35	28480	1901-0376
A41CR4	1901-0033	2		DIODE-GEN PRP 180V 200MA DO-7	28480	1901-0033
A41CR5	1901-0033	2		DIODE-GEN PRP 180V 200MA DO-7	28480	1901-0033
A41CR6	1901-0033	2		DIODE-GEN PRP 180V 200MA DO-7	28480	1901-0033
A41L1	9100-1651	2	1	INDUCTOR RF-CH-MLD 750UH 5% .2DX.45LG	28480	9100-1651
A41L2	9140-0144	0	3	INDUCTOR RF-CH-MLD 4.7UH 10% .105DX.26LG	28480	9140-0144
A41L3	9140-0144	0		INDUCTOR RF-CH-MLD 4.7UH 10% .105DX.26LG	28480	9140-0144
A41L4	9140-0144	0		INDUCTOR RF-CH-MLD 4.7UH 10% .105DX.26LG	28480	9140-0144
A41MP1	2190-0009	4	2	WASHER-LK INTL T NO. 8 .168-IN-ID	28480	2190-0009
A41MP2	2190-0009	4		WASHER-LK INTL T NO. 8 .168-IN-ID	28480	2190-0009
A41MP3	2200-0101	0	2	SCREW-MACH 4-40 .188-IN-LG PAN-HD-POZI	00000	ORDER BY DESCRIPTION
A41MP4	2200-0101	0		SCREW-MACH 4-40 .188-IN-LG PAN-HD-POZI	00000	ORDER BY DESCRIPTION
A41MP5	2580-0002	4	2	NUT-HEX-DBL-CHAM 8-32-THD .085-IN-THK	00000	ORDER BY DESCRIPTION
A41MP6	2580-0002	4		NUT-HEX-DBL-CHAM 8-32-THD .085-IN-THK	00000	ORDER BY DESCRIPTION
A41MP7	08340-20087	8	1	COVER-PC 2 PHASE DETECTOR	28480	08340-20087
A41MP8	86701-40001	9	2	EXTRACTOR-PC BOARD	28480	86701-40001
A41MP9	86701-40001	9		EXTRACTOR-PC BOARD	28480	86701-40001
A41Q1	1853-0281	9	2	TRANSISTOR PNP 2N2907A SI TO-18 PD=400MW	04713	2N2907A
A41Q2	1854-0477	7	1	TRANSISTOR NPN 2N2222A SI TO-18 PD=500MW	04713	2N2222A
A41Q3	1855-0386	9	1	TRANSISTOR J-FET 2N4392 N-CHAN D-MODE	04713	2N4392
A41Q4	1853-0281	9	1	TRANSISTOR PNP 2N2907A SI TO-18 PD=400MW	02037	2N2907A
A41Q5	1854-0477	7	1	TRANSISTOR NPN 2N2222A SI TO-18 PD=500MW	02037	2N2222A
A41Q6	1854-0404	0	2	TRANSISTOR NPN SI TO-18 PD=360MW	28480	1854-0404
A41Q7	1853-0281	9		TRANSISTOR PNP 2N2907A SI TO-18 PD=400MW	04713	2N2907A
A41Q8	1854-0404	0		TRANSISTOR NPN SI TO-18 PD=360MW	28480	1854-0404
A41Q9	1853-0007	7	2	TRANSISTOR PNP 2N3251 SI TO-18 PD=360MW	04713	2N3251
A41Q10	1853-0007	7		TRANSISTOR PNP 2N3251 SI TO-18 PD=360MW	04713	2N3251
A41R1	0757-0280	3	5	RESISTOR 1K 1% .125W F TC=0+100	24546	C4-1/8-T0-1001-F
A41R2	0757-0317	7	2	RESISTOR 1.33K 1% .125W F TC=0+100	24546	C4-1/8-T0-1331-F
A41R3	0757-0280	3		RESISTOR 1K 1% .125W F TC=0+100	24546	C4-1/8-T0-1001-F
A41R4	0757-0317	7		RESISTOR 1.33K 1% .125W F TC=0+100	24546	C4-1/8-T0-1331-F
A41R5	0698-0083	8	1	RESISTOR 1.96K 1% .125W F TC=0+100	24546	C4-1/8-T0-1961-F
A41R6	0698-3440	7	1	RESISTOR 196 1% .125W F TC=0+100	24546	C4-1/8-T0-196R-F
A41R7	0757 0123	3	1	RESISTOR 34.8K 1% .125W F TC=0+100	28480	0757-0123
A41R8	0698-0082	7	1	RESISTOR 464 1% .125W F TC=0+100	24546	C4-1/8-T0-4640-F
A41R9	0757-0442	9	2	RESISTOR 10K 1% .125W F TC=0+100	24546	C4-1/8-T0-1002-F
A41R10	0698-3260	9	1	RESISTOR 464K 1% .125W F TC=0+100	28480	0698-3260
A41R11	0757-0290	5	1	RESISTOR 6.19K 1% .125W F TC=0+100	19701	MF4C1/8-T0-6191-F
A41R12	0757-0420	3	1	RESISTOR 750 1% .125W F TC=0+100	24546	C4-1/8-T0-751-F
A41R13	0698-0084	9	3	RESISTOR 2.15K 1% .125W F TC=0+100	24546	C4-1/8-T0-2151-F
A41R14	0757-0280	3		RESISTOR 1K 1% .125W F TC=0+100	24546	C4-1/8-T0-1001-F
A41R15	0757-0442	9		RESISTOR 10K 1% .125W F TC=0+100	24546	C4-1/8-T0-1002-F
A41R16	0757-0438	3	1	RESISTOR 5.11K 1% .125W F TC=0+100	24546	C4-1/8-T0-5111-F
A41R17	0757-0444	1	1	RESISTOR 12.1K 1% .125W F TC=0+100	24546	C4-1/8-T0-1212-F
A41R18	0698-0084	9		RESISTOR 2.15K 1% .125W F TC=0+100	24546	C4-1/8-T0-2151-F

See introduction to this section for ordering information
 *Indicates factory selected value

Table 6-3. Model 8340A Replaceable Parts

Reference Designation	HP Part Number	C D	Qty	Description	Mfr Code	Mfr Part Number
A41R19	0757-0280	3		RESISTOR 1K 1% .125W F TC=0+100	24546	C4-1/8-T0-1001-F
A41R20	0698-3445	2	3	RESISTOR 348 1% .125W F TC=0+100	24546	C4-1/8-T0-348R-F
A41R21	0698-3445	2		RESISTOR 348 1% .125W F TC=0+100	24546	C4-1/8-T0-348R-F
A41R22	0757-0280	3		RESISTOR 1K 1% .125W F TC=0+100	24546	C4-1/8-T0-1001-F
A41R23	0757-0279	0	1	RESISTOR 3.16K 1% .125W F TC=0+100	24546	C4-1/8-T0-3161-F
A41R24	0698-3450	9	1	RESISTOR 42.2K 1% .125W F TC=0+100	24546	C4-1/8-T0-4222-F
A41R25	0757-0462	3	1	RESISTOR 75K 1% .125W F TC=0+100	24546	C4-1/8-T0-7502-F
A41R26	0757-0467	8	1	RESISTOR 121K 1% .125W F TC=0+100	24546	C4-1/8-T0-1213-F
A41R27	0698-3266	5	1	RESISTOR 237K 1% .125W F TC=0+100	24546	C4-1/8-T0-2373-F
A41R28	0698-3460	1	1	RESISTOR 422K 1% .125W F TC=0+100	28480	0698-3460
A41R29	0757-0438	3	2	RESISTOR 5.11K 1% .125W F TC=0+100	24546	C4-1/8-T0-5111-F
A41R30	0698-0084	9		RESISTOR 2.15K 1% .125W F TC=0+100	24546	C4-1/8-T0-2151-F
A41R31	0698-3154	0	1	RESISTOR 4.22K 1% .125W F TC=0+100	24546	C4-1/8-T0-4221-F
A41R32	0757-0438	3		RESISTOR 5.11K 1% .125W F TC=0+100	24546	C4-1/8-T0-5111-F
A41R33	0698-0085	0	1	RESISTOR 2.61K 1% .125W F TC=0+100	24546	C4-1/8-T0-2611-F
A41R34	0698-3445	2		RESISTOR 348 1% .125W F TC=0+100	24546	C4-1/8-T0-348R-F
A41R35	0757-0346	2	1	RESISTOR 10 1% .125W F TC=0+100	24546	C4-1/8-T0-10R0-F
A41R36	0757-0440	7	1	RESISTOR 7.5K 1% .125W F TC=0+100	24546	C4-1/8-T0-7501-F
A41TP1	0360-0535	0	5	TERMINAL TEST POINT PCB	00000	ORDER BY DESCRIPTION
A41TP2	0360-0535	0		TERMINAL TEST POINT PCB	00000	ORDER BY DESCRIPTION
A41TP3	0360-0535	0		TERMINAL TEST POINT PCB	00000	ORDER BY DESCRIPTION
A41TP4	0360-0535	0		TERMINAL TEST POINT PCB	00000	ORDER BY DESCRIPTION
A41TP5	0360-0535	0		TERMINAL TEST POINT PCB	00000	ORDER BY DESCRIPTION
A41U1	1826-0026	3	1	IC COMPARATOR PRCN TO-99 PKG	01295	LM311L
A41U2	1826-0459	6	1	IC OP AMP 14-DIP-C PKG	27014	LH0042CD
A41U3	1826-0471	2	1	IC OP AMP LOW-DRIFT TO-99 PKG	28480	1826-0471
A41U4	1826-0059	2	1	IC OP AMP GP TO-99 PKG	01295	LM201AL
A41U5	1820-0429	8	1	IC V RGLTR TO-39	18324	LM309H
A41U6	1820-1212	9	1	IC FF TTL LS J-K NEG-EDGE-TRIG	01295	SN74LS112AN
A41U7	1820-1425	6	1	IC SCHMITT-TRIG TTL LS NAND QUAD 2-INP	01295	SN74LS132N
A41U8	1820-1194	6	2	IC CNTR TTL LS BIN UP/DOWN SYNCHRO	01295	SN74LS193N
A41U9	1820-1194	6		IC CNTR TTL LS BIN UP/DOWN SYNCHRO	01295	SN74LS193N
A41U10	1826-0448	3	1	IC- 7533C PI DAC	24355	AD7520LN (SEL)
A41VR1				NOT ASSIGNED		
A41VR2	1902-0041	4	2	DIODE-ZNR 5.11V 5% DO-35 PD=.4W	28480	1902-0041
A41VR3	1902-0041	4		DIODE-ZNR 5.11V 5% DO-35 PD=.4W	28480	1902-0041
A41VR4	1902-3002	3	1	DIODE-ZNR 2.37V 5% DO-7 PD=.4W TC=-.074%	28480	1902-3002

See introduction to this section for ordering information
 *Indicates factory selected value

Table 6-3. Model 8340A Replaceable Parts

Reference Designation	HP Part Number	C D	Qty	Description	Mfr Code	Mfr Part Number
A42	08340-60048	5	1	PPL2 DIVIDER	28480	08340-60048
A42C1	0160-3877	5	2	CAPACITOR-FXD 100PF +20% 200VDC CER	28480	0160-3877
A42C2	0160-3879	7	2	CAPACITOR-FXD .01UF ±20% 100VDC CER	28480	0160-3879
A42C3	0160-4084	8	12	CAPACITOR-FXD .1UF +20% 50VDC CER	28480	0160-4084
A42C4	0160-3877	5		CAPACITOR-FXD 100PF +20% 200VDC CER	28480	0160-3877
A42C5	0160-4084	8		CAPACITOR-FXD .1UF ±20% 50VDC CER	28480	0160-4084
A42C6	0160-4084	8		CAPACITOR-FXD .1UF +20% 50VDC CER	28480	0160-4084
A42C7	0160-4084	8		CAPACITOR-FXD .1UF ±20% 50VDC CER	28480	0160-4084
A42C8	0160-3879	7		CAPACITOR-FXD .01UF +20% 100VDC CER	28480	0160-3879
A42C9	0160-4084	8		CAPACITOR-FXD .1UF +20% 50VDC CER	28480	0160-4084
A42C10	0160-4084	8		CAPACITOR-FXD .1UF ±20% 50VDC CER	28480	0160-4084
A42C11	0160-4084	8		CAPACITOR-FXD .1UF +20% 50VDC CER	28480	0160-4084
A42C12	0160-4084	8		CAPACITOR-FXD .1UF ±20% 50VDC CER	28480	0160-4084
A42C13	0160-4084	8		CAPACITOR-FXD .1UF ±20% 50VDC CER	28480	0160-4084
A42C14	0160-0570	9	1	CAPACITOR-FXD 220PF +20% 100VDC CER	20932	5024EM100RD221M
A42C15	0160-4084	8		CAPACITOR-FXD .1UF ±20% 50VDC CER	28480	0160-4084
A42C16	0160-4084	8		CAPACITOR-FXD .1UF +20% 50VDC CER	28480	0160-4084
A42C17	0160-4084	8		CAPACITOR-FXD .1UF +20% 50VDC CER	28480	0160-4084
A42C18	0180-1746	5	2	CAPACITOR-FXD 150PF±10% 20VDC TA	56289	150D156X9020B2
A42C19	0180-1746	5		CAPACITOR-FXD 150PF±10% 20VDC TA	56289	150D156X9020B2
A42CR1	1901-0743	1	2	DIODE-PWR RECT 1N4004 400V 1A DO-41	01295	1N4004
A42CR2	1901-0743	1		DIODE-PWR RECT 1N4004 400V 1A DO-41	01295	1N4004
A42J1	1250-0544	9	1	CONNECTOR-RF MALE SMB	28480	1250-0544
A42L1	9100-2250	9	1	INDUCTOR RF-CH-MLD 180NH 10% .105DX.26LG	28480	9100-2250
A42L2	9100-1788	6	1	CHOKE-WIDE BAND ZMAX=680 OHM@ 180 MHZ	02114	VK200 20/48
A42L3	9100-1618	1	2	INDUCTOR RF-CH-MLD 5.6UH 10%	28480	9100-1618
A42L4	9100-1618	1		INDUCTOR RF-CH-MLD 5.6UH 10%	28480	9100-1618
A42MP1	2190-0124	4	1	WASHER-LK INTL T NO. 10 .195-IN-ID	28480	2190-0124
A42MP2	2200-0101	0	2	SCREW-MACH 4-40 .188-IN-LG PAN-HD-POZI	00000	ORDER BY DESCRIPTION
A42MP3	2200-0101	0		SCREW-MACH 4-40 .188-IN-LG PAN-HD-POZI	00000	ORDER BY DESCRIPTION
A42MP4	2950-0078	9	1	NUT-HEX-DBL-CHAM 10-32-THD .067-IN-THK	28480	2950-0078
A42MP5	08340-20088	9	1	COVER-PC PLL2 DRIVER	28480	08340-20088
A42MP6	86701-40001	9	2	EXTRACTOR-PC BOARD	28480	86701-40001
A42MP7	86701-40001	9		EXTRACTOR-PC BOARD	28480	86701-40001
A42Q1	1854-0546	1	1	TRANSISTOR NPN SI TO-72 PD=200MW	28480	1854-0546
A42Q2	1854-0019	3	1	TRANSISTOR NPN SI TO-18 PD=360MW	28480	1854-0019
A42R1	0757-0276	7	1	RESISTOR 61.9 1% .125W F TC=0+100	24546	C4-1/8-T0-6192-F
A42R2	0757-0279	0	1	RESISTOR 3.16K 1% .125W F TC=0+100	24546	C4-1/8-T0-3161-F
A42R3	0757-0280	3	7	RESISTOR 1K 1% .125W F TC=0+100	24546	C4-1/8-T0-1001-F
A42R4	0757-0395	1	1	RESISTOR 56.2 1% .125W F TC=0+100	24546	C4-1/8-T0-56R2-F
A42R5	0757-0401	0	1	RESISTOR 100 1% .125W F TC=0+100	24546	C4-1/8-T0-101-F
A42R6	0757-0280	3		RESISTOR 1K 1% .125W F TC=0+100	24546	C4-1/8-T0-1001-F
A42R7	0698-3444	1	1	RESISTOR 316 1% .125W F TC=0+100	24546	C4-1/8-T0-316R-F
A42R8	0698-3157	3	1	RESISTOR 19.6K 1% .125W F TC=0+100	24546	C4-1/8-T0-1962-F
A42R9	0757-0280	3		RESISTOR 1K 1% .125W F TC=0+100	24546	C4-1/8-T0-1001-F
A42R10	0757-0280	3		RESISTOR 1K 1% .125W F TC=0+100	24546	C4-1/8-T0-1001-F
A42R11	0757-0280	3		RESISTOR 1K 1% .125W F TC=0+100	24546	C4-1/8-T0-1001-F
A42R12	0757-0280	3		RESISTOR 1K 1% .125W F TC=0+100	24546	C4-1/8-T0-1001-F
A42R13	0757-0280	3		RESISTOR 1K 1% .125W F TC=0+100	24546	C4-1/8-T0-1001-F
A42R14	0757-0442	9	1	RESISTOR 10K 1% .125W F TC=0+100	24546	C4-1/8-T0-1002-F
A42TP1	0360-0535	0	5	TERMINAL TEST POINT PCB	00000	ORDER BY DESCRIPTION
A42TP2	0360-0535	0		TERMINAL TEST POINT PCB	00000	ORDER BY DESCRIPTION
A42TP3	0360-0535	0		TERMINAL TEST POINT PCB	00000	ORDER BY DESCRIPTION
A42TP4	0360-0535	0		TERMINAL TEST POINT PCB	00000	ORDER BY DESCRIPTION
A42TP5	0360-0535	0		TERMINAL TEST POINT PCB	00000	ORDER BY DESCRIPTION
A42U1	1820-1888	5	1	IC PRESCR ECL	04713	MC12013L
A42U2	1820-0681	4	1	IC GATE TTL S NAND QUAD 2-INP	01295	SN74S00N
A42U3	1820-0629	0	2	IC FF TTL S J-K NEG-EDGE-TRIG	01295	SN74S112N
A42U4	1820-1251	6	5	IC CNTR TTL LS DECD ASYNCHRO	01295	SN74LS196N
A42U5	1820-0909	9	2	IC MULTR TTL	01295	SN74167N
A42U6	1820-0909	9		IC MULTR TTL	01295	SN74167N
A42U7	1820-1251	6		IC CNTR TTL LS DECD ASYNCHRO	01295	SN74LS196N
A42U8	1820-1251	6		IC CNTR TTL LS DECD ASYNCHRO	01295	SN74LS196N
A42U9	1820-0686	9	1	IC GATE TTL S AND TPL 3-INP	01295	SN74S11N
A42U10	1820-0629	0		IC FF TTL S J-K NEG-EDGE-TRIG	01295	SN74S112N
A42U11	1820-0261	6	1	IC MV TTL MONOSTBL	01295	SN74121N
A42U12	1820-1196	8	3	IC FF TTL LS D-TYPE POS-EDGE-TRIG COM	01295	SN74LS174N
A42U13	1820-1196	8		IC FF TTL LS D-TYPE POS-EDGE-TRIG COM	01295	SN74LS174N
A42U14	1820-1196	8		IC FF TTL LS D-TYPE POS-EDGE-TRIG COM	01295	SN74LS174N
A42U15	1820-1251	6		IC CNTR TTL LS DECD ASYNCHRO	01295	SN74LS196N

See introduction to this section for ordering information
 *Indicates factory selected value

Table 6-3. Model 8340A Replaceable Parts

Reference Designation	HP Part Number	C D	Qty	Description	Mfr Code	Mfr Part Number
A42U16	1820-1251	6		IC CNTR TTL LS DECD ASYNCHRO	01295	SN74LS196N
A42W1	08340-60111	3	1	CABLE ASSEMBLY- A42	28480	08340-60111

See introduction to this section for ordering information
 *Indicates factory selected value

Table 6-3. Model 8340A Replaceable Parts

Reference Designation	HP Part Number	C D	Qty	Description	Mfr Code	Mfr Part Number
A43	08340-60049	6	1	PLL2 DISCRIMINATOR	28480	08340-60049
A43C1	0160-4084	8	10	CAPACITOR-FXD .1UF +20% 50VDC CER	28480	0160-4084
A43C2	0160-4084	8		CAPACITOR-FXD .1UF +20% 50VDC CER	28480	0160-4084
A43C3	0160-4084	8		CAPACITOR-FXD .1UF +20% 50VDC CER	28480	0160-4084
A43C4	0180-0291	3	1	CAPACITOR-FXD 1UF+10% 35VDC TA	56289	150D105X9035A2
A43C5	0180-0197	8	2	CAPACITOR-FXD 2.2UF+10% 20VDC TA	56289	150D225X9020A2
A43C6	0180-0197	8		CAPACITOR-FXD 2.2UF+10% 20VDC TA	56289	150D225X9020A2
A43C7	0160-4084	8		CAPACITOR-FXD .1UF +20% 50VDC CER	28480	0160-4084
A43C8	0180-0229	7	1	CAPACITOR-FXD 33UF+10% 10VDC TA	56289	150D336X9010B2
A43C9	0160-3879	7	3	CAPACITOR-FXD .01UF +20% 100VDC CER	28480	0160-3879
A43C10	0160-2199	2	2	CAPACITOR-FXD 30PF +5% 300VDC MICA	28480	0160-2199
A43C11	0160-4084	8		CAPACITOR-FXD .1UF +20% 50VDC CER	28480	0160-4084
A43C12	0160-0571	0	1	CAPACITOR-FXD 470PF +20% 100VDC CER	28480	0160-0571
A43C13	0160-0127	2	2	CAPACITOR-FXD 1UF +20% 25VDC CER	28480	0160-0127
A43C14	0160-4084	8		CAPACITOR-FXD .1UF +20% 50VDC CER	28480	0160-4084
A43C15	0160-4605	9	1	CAPACITOR-CFR 36 PF 500VDC	28480	0160-4605
A43C16	0160-2252	8	1	CAPACITOR-FXD 6.2PF +.25PF 500VDC CER	28480	0160-2252
A43C17	0160-3877	5	2	CAPACITOR-FXD 100PF +20% 200VDC CER	28480	0160-3877
A43C18	0160-4084	8		CAPACITOR-FXD .1UF +20% 50VDC CER	28480	0160-4084
A43C19	0160-4084	8		CAPACITOR-FXD .1UF +20% 50VDC CER	28480	0160-4084
A43C20	0160-3879	7		CAPACITOR-FXD .01UF +20% 100VDC CER	28480	0160-3879
A43C21	0160-4084	8		CAPACITOR-FXD .1UF +20% 50VDC CER	28480	0160-4084
A43C22	0160-3879	7		CAPACITOR-FXD .01UF +20% 100VDC CER	28480	0160-3879
A43C23	0160-0161	4	1	CAPACITOR-FXD .01UF +10% 200VDC POLYE	28480	0160-0161
A43C24	0160-4084	8		CAPACITOR-FXD .1UF +20% 50VDC CER	28480	0160-4084
A43C25	0160-3456	6	1	CAPACITOR-FXD 1000PF +10% 1KVDC CER	28480	0160-3456
A43C26	0160-2199	2		CAPACITOR-FXD 30PF +5% 300VDC MICA	28480	0160-2199
A43C27	0160-3877	5		CAPACITOR-FXD 100PF +20% 200VDC CER	28480	0160-3877
A43C28	0160-0127	2		CAPACITOR-FXD 1UF +20% 25VDC CER	28480	0160-0127
A43C29	0160-2437	1	1	CAPACITOR-FDTHRU 5000PF +80 -20% 200V	28480	0160-2437
A43CR1	1901-0539	3	2	DIODE-SM SIG SCHOTTKY	28480	1901-0539
A43CR2	1901-0539	3		DIODE-SM SIG SCHOTTKY	28480	1901-0539
A43J1	1250-0544	9	1	CONNECTOR-RF MALE SMB	28480	1250-0544
A43L1	9140-0144	0	4	INDUCTOR RF-CH-MLD 4.7UH 10% .105DX.26LG	28480	9140-0144
A43L2	9140-0144	0		INDUCTOR RF-CH-MLD 4.7UH 10% .105DX.26LG	28480	9140-0144
A43L3	9140-0144	0		INDUCTOR RF-CH-MLD 4.7UH 10% .105DX.26LG	28480	9140-0144
A43L4	9140-0392	0	1	INDUCTOR RF-CH-MLD 22UH 3% .166DX.385LG	28480	9140-0392
A43L5	9100-1629	4	1	INDUCTOR RF-CH-MLD 47UH 5% .166DX.385LG	28480	9100-1629
A43L6	9100-1666	9	1	INDUCTOR RF-CH-MLD 3.6MH 5% .23DX.57LG	28480	9100-1666
A43L7	9140-0144	0		INDUCTOR RF-CH-MLD 4.7UH 10% .105DX.26LG	28480	9140-0144
A43MP1				NOT ASSIGNED		
A43MP2				NOT ASSIGNED		
A43MP3	1205-0250	9	1	THERMAL LINK SGL TO-5/TO-39-CS	28480	1205-0250
A43MP4	2190-0009	4	1	WASHER-LK INTL T NO. 8 .168-IN-ID	28480	2190-0009
A43MP5	2190-0124	4	1	WASHER-LK INTL T NO. 10 .195-IN-ID	28480	2190-0124
A43MP6	2200-0101	0	5	SCREW-MACH 4-40 .188-IN-LG PAN-HD-POZI	00000	ORDER BY DESCRIPTION
A43MP7	2200-0101	0		SCREW-MACH 4-40 .188-IN-LG PAN-HD-POZI	00000	ORDER BY DESCRIPTION
A43MP8	2200-0101	0		SCREW-MACH 4-40 .188-IN-LG PAN-HD-POZI	00000	ORDER BY DESCRIPTION
A43MP9	2200-0101	0		SCREW-MACH 4-40 .188-IN-LG PAN-HD-POZI	00000	ORDER BY DESCRIPTION
A43MP10	2200-0101	0		SCREW-MACH 4-40 .188-IN-LG PAN-HD-POZI	00000	ORDER BY DESCRIPTION
A43MP11	2200-0164	5	1	SCREW-MACH 4-40 .188-IN-LG UNCT 82 DEG	00000	ORDER BY DESCRIPTION
A43MP12	2580-0002	4	1	NUT-HEX-DBL-CHAM 8-32-THD .085-IN-THK	00000	ORDER BY DESCRIPTION
A43MP13	2950-0078	9	1	NUT-HEX-DBL-CHAM 10-32-THD .067-IN-THK	28480	2950-0078
A43MP14	08340-00037	6	1	SHIELD-PLL2 DISCRIMINATOR	28480	08340-00037
A43MP15	08340-20089	0	1	COVER-PC 2 DISCRIMINATOR	28480	08340-20089
A43MP16	86701-40001	9	1	EXTRACTOR-PC BOARD	28480	86701-40001
A43Q1	1854-0404	0	1	TRANSISTOR NPN SI TO-18 PD=360MW	28480	1854-0404
A43Q2	1853-0281	9	2	TRANSISTOR PNP 2N2907A SI TO-18 PD=400MW	04713	2N2907A
A43Q3	1854-0475	5	1	TRANSISTOR-DUAL NPN PD=750MW	28480	1854-0475
A43Q4	1855-0413	3	1	TRANSISTOR J-FET P-CHAN D-MODE TO-18 SI	27014	2N5116
A43Q5	1853-0269	3	1	TRANSISTOR-DUAL PNP 2N3809 PD=600MW	01295	2N3809
A43Q6	1853-0007	7	1	TRANSISTOR PNP 2N3251 SI TO-18 PD=360MW	04713	2N3251
A43Q7	1854-0019	3	1	TRANSISTOR NPN SI TO-18 PD=360MW	28480	1854-0019
A43Q8	1853-0281	9		TRANSISTOR PNP 2N2907A SI TO-18 PD=400MW	04713	2N2907A
A43Q9	1854-0247	9	1	TRANSISTOR NPN SI TO-39 PD=1W FT=800MHZ	28480	1854-0247
A43Q10	1853-0388	7	1	TRANSISTOR-DUAL PNP PD=600MW	28480	1853-0388
A43Q11	1853-0034	0	1	TRANSISTOR PNP SI TO-18 PD=360MW	28480	1853-0034
A43R1	0757-0346	2	1	RESISTOR 10 1% .125W F TC=0+100	24546	C4-1/8-T0-10R0-F
A43R2	0757-0199	3	1	RESISTOR 21.5K 1% .125W F TC=0+100	24546	C4-1/8-T0-2152-F
A43R3	0757-0123	3	1	RESISTOR 34.8K 1% .125W F TC=0+100	28480	0757-0123

See introduction to this section for ordering information
 *Indicates factory selected value

Table 6-3. Replaceable Parts

Reference Designation	HP Part Number	C D	Qty	Description	Mfr Code	Mfr Part Number
A43R4	0757-0442	9	1	RESISTOR 10K 1% .125W F TC=0+-100	24546	C4-1/8-T0-1002-F
A43R5	0699-3132	4	1	RESISTOR 261 1% .125W F TC=0+-100	24546	C4-1/8-T0-2610-F
A43R6	0699-0078	3	3	RESISTOR-FXD 2.1K OHM .1% .1W	28480	0699-0078
A43R7	0699-0078	3		RESISTOR-FXD 2.1K OHM .1% .1W	28480	0699-0078
A43R8	0699-0078	3		RESISTOR-FXD 2.1K OHM .1% .1W	28480	0699-0078
A43R9	2100-1739	0	1	RESISTOR-TRMR 5K 10% WW SIDE-ADJ 20-TRN	02660	3810P-502
A43R10	0699-0082	9	1	RESISTOR-FXD 215 OHM .1% .1W	28480	0699-0082
A43R11	0757-0280	3	9	RESISTOR 1K 1% .125W F TC=0+-100	24546	C4-1/8-T0-1001-F
A43R12	0757-0280	3		RESISTOR 1K 1% .125W F TC=0+-100	24546	C4-1/8-T0-1001-F
A43R13	0757-0280	3		RESISTOR 1K 1% .125W F TC=0+-100	24546	C4-1/8-T0-1001-F
A43R14	0699-3153	9	2	RESISTOR 3.83K 1% .125W F TC=0+-100	24546	C4-1/8-T0-3831-F
A43R15	0757-0280	3		RESISTOR 1K 1% .125W F TC=0+-100	24546	C4-1/8-T0-1001-F
A43R16	0699-3151	7	1	RESISTOR 2.87K 1% .125W F TC=0+-100	24546	C4-1/8-T0-2871-F
A43R17	0757-0280	3		RESISTOR 1K 1% .125W F TC=0+-100	24546	C4-1/8-T0-1001-F
A43R18	0699-3445	2	1	RESISTOR 348 1% .125W F TC=0+-100	24546	C4-1/8-T0-3481-F
A43R19	0699-3447	4	1	RESISTOR 422 1% .125W F TC=0+-100	24546	C4-1/8-T0-4221-F
A43R20	0757-1094	9	2	RESISTOR 1.47K 1% .125W F TC=0+-100	24546	C4-1/8-T0-1471-F
A43R21	0699-3444	1	1	RESISTOR 316 1% .125W F TC=0+-100	24546	C4-1/8-T0-3161-F
A43R22	0757-0280	3		RESISTOR 1K 1% .125W F TC=0+-100	24546	C4-1/8-T0-1001-F
A43R23	0699-3152	8	1	RESISTOR 3.48K 1% .125W F TC=0+-100	24546	C4-1/8-T0-3481-F
A43R24	0757-1094	9		RESISTOR 1.47K 1% .125W F TC=0+-100	24546	C4-1/8-T0-1471-F
A43R25	2100-1972	3	1	RESISTOR-TRMR 20K 10% WW SIDE-ADJ 20-TRN	02660	3810P-203
A43R26	0699-0081	8	1	RESISTOR-FXD 390.1K OHM .1% .12W	28480	0699-0081
A43R27	2100-2851	9	1	RESISTOR-TRMR 2K 10% WW SIDE-ADJ 20-TRN	02660	3810P-202
A43R28	0699-0080	7	1	RESISTOR-FXD 39K OHM .1% .12W	28480	0699-0080
A43R29	0699-3499	6	3	RESISTOR 40.2K 1% .125W F TC=0+-100	24546	C4-1/8-T0-4022-F
A43R30	0699-3499	6		RESISTOR 40.2K 1% .125W F TC=0+-100	24546	C4-1/8-T0-4022-F
A43R31	0699-3499	6		RESISTOR 40.2K 1% .125W F TC=0+-100	24546	C4-1/8-T0-4022-F
A43R32	0699-3153	9		RESISTOR 3.83K 1% .125W F TC=0+-100	24546	C4-1/8-T0-3831-F
A43R33	0699-0084	1	1	RESISTOR-FXD 6.19K OHM .1% .1W	28480	0699-0084
A43R34	0699-0083	0	1	RESISTOR-FXD 881 OHM .1% .1W	28480	0699-0083
A43R35	0757-0400	9	1	RESISTOR 90.9 1% .125W F TC=0+-100	24546	C4-1/8-T0-90R9-F
A43R36	0699-0083	8	1	RESISTOR 1.96K 1% .125W F TC=0+-100	24546	C4-1/8-T0-1961-F
A43R37	0699-0084	9	1	RESISTOR 2.15K 1% .125W F TC=0+-100	24546	C4-1/8-T0-2151-F
A43R38	0757-0280	3		RESISTOR 1K 1% .125W F TC=0+-100	24546	C4-1/8-T0-1001-F
A43R39	0757-0280	3		RESISTOR 1K 1% .125W F TC=0+-100	24546	C4-1/8-T0-1001-F
A43R40	0699-0079	4	1	RESISTOR-FXD 4.667K OHM .1% .1W	28480	0699-0079
A43R41	2100-1799	2	1	RESISTOR-TRMR 500 10% WW SIDE-ADJ 20-TRN	02660	3810P-501
A43R42	0699-8831	0	1	RESISTOR 13.4K .1% .125W F TC=0+-10	28480	0699-8831
A43R43	0757-0274	5	1	RESISTOR 1.21K 1% .125W F TC=0+-100	24546	C4-1/8-T0-1211-F
A43R44	0699-0085	0	1	RESISTOR 2.61K 1% .125W F TC=0+-100	24546	C4-1/8-T0-2611-F
A43R45	0699-3150	6	1	RESISTOR 2.37K 1% .125W F TC=0+-100	24546	C4-1/8-T0-2371-F
A43R46	0757-0280	3		RESISTOR 1K 1% .125W F TC=0+-100	24546	C4-1/8-T0-1001-F
A43R47	0757-0438	3	1	RESISTOR 5.11K 1% .125W F TC=0+-100	24546	C4-1/8-T0-5111-F
A43R48	0757-0394	0	1	RESISTOR 51.1 1% .125W F TC=0+-100	24546	C4-1/8-T0-51R1-F
A43R49	0757-0401	0	2	RESISTOR 100 1% .125W F TC=0+-100	24546	C4-1/8-T0-101-F
A43R50	0757-0401	0		RESISTOR 100 1% .125W F TC=0+-100	24546	C4-1/8-T0-101-F
A43TP1	0360-0535	0	6	TERMINAL TEST POINT PCB	00000	ORDER BY DESCRIPTION
A43TP2	0360-0535	0		TERMINAL TEST POINT PCB	00000	ORDER BY DESCRIPTION
A43TP3	0360-0535	0		TERMINAL TEST POINT PCB	00000	ORDER BY DESCRIPTION
A43TP4	0360-0535	0		TERMINAL TEST POINT PCB	00000	ORDER BY DESCRIPTION
A43TP5				See A43C29		
A43TP6	0360-0535	0		TERMINAL TEST POINT PCB	00000	ORDER BY DESCRIPTION
A43TP7	0360-0535	0		TERMINAL TEST POINT PCB	00000	ORDER BY DESCRIPTION
A43U1	1826-0811	4	2	ANALOG SWITCH 4 SPST 16 CERDIP	02180	SW-01FQ
A43U2	1826-0811	4		ANALOG SWITCH 4 SPST 16 CERDIP	02180	SW-01FQ
A43U3	1826-0471	2	1	IC OP AMP LOW-DRIFT TO-99 PKG	28480	1826-0471
A43U4	1820-0223	0	2	IC OP AMP GP TO-99 PKG	3L585	CA301AT
A43U5	1820-0429	8	1	IC V RGLTR TO-39	18324	LM309H
A43U6	1820-1194	6	1	IC CNTR TTL LS BIN UP/DOWN SYNCHRO	01295	SN74LS193N
A43U7	1820-1144	6	1	IC GATE TTL LS NOR QUAD 2-INP	01295	SN74LS02N
A43U8	1826-0353	9	1	IC 786L 15 V RGLTR TO-39	07263	UA78L15ACH
A43U9	1820-1196	8	2	IC FF TTL LS D-TYPE POS-EDGE-TRIG COM	01295	SN74LS174N
A43U10	1826-0059	2	1	IC OP AMP GP TO-99 PKG	01295	LM201AL
A43U11	1826-0448	3	1	IC CONV 10-B-D/A 16-DIP-P PKG	24355	AD7520LN(SEL)
A43U12	1820-1196	8		IC FF TTL LS D-TYPE POS-EDGE-TRIG COM	01295	SN74LS174N
A43U13	1820-0223	0		IC OP AMP GP TO-99 PKG	3L585	CA301AT
A43VR1	1902-0692	1	1	DIODE-ZNR 6.3V 1% DO-7 PD=4W TC=+.001%	28480	1902-0692
A43W1	08340-60112	4	1	CABLE ASSEMBLY- A43	28480	08340-60112

See Introduction to the Section for ordering information.

*Indicates factory selected value.

Table 6-3. Model 8340A Replaceable Parts

Reference Designation	HP Part Number	C D	Qty	Description	Mfr Code	Mfr Part Number
A44	5086-7323	1	1	YIG OSCILLATOR 2.3 60 7.0 GHZ (5086-7323 INCLUDES A44 YIG OSCILLATOR AND A44A1 BIAS BOARD.)	28480	5086-7323
	5086-6323	9	1	EXCHANGE 5086-7323 YIG OSCILLATOR	28480	5086-6323
A44A1	5061-1089	2	1	YIG OSCILLATOR BIAS BOARD	28480	5061-1089
A44A1C1	0160-0127	2	2	CAPACITOR-FXD 1UF +20% 25VDC CER	28480	0160-0127
A44A1C2	0160-0127	2	2	CAPACITOR-FXD 1UF +20% 25VDC CER	28480	0160-0127
A44A1C3	0160-0299	9	1	CAPACITOR-FXD 1800PF +10% 200VDC POLYE	28480	0160-0299
A44A1C4	0170-0040	9	1	CAPACITOR-FXD .047UF +10% 200VDC POLYE	56289	292P47392
A44A1C5	0160-0161	4	1	CAPACITOR-FXD .01UF +10% 200VDC POLYE	28480	0160-0161
A44A1CRI	1901-0033	2	1	DIODE-GEN PRP 180V 200MA DO-7	28480	1901-0033
A44A1J1	1200-0482	9	2	SOCKET-IC 16-CONT DIP-SLDR	28480	1200-0482
A44A1J2	1250-0257	1	1	CONNECTOR-RF SMB M PC 50-OHM	28480	1250-0257
A44A1MP1	1251-2194	1	2	CONNECTOR-SGL CONT SKT .021-IN-BSC-SZ	28480	1251-2194
A44A1MP2	1251-3172	7	2	CONNECTOR-SGL CONT SKT .03-IN-BSC-SZ RND	28480	1251-3172
A44A1MP3	0380-1104	3	2	SPACER- .094 L .152 ID	00000	ORDER BY DESCRIPTION
A44A1Q1	1853-0038	4	1	TRANSISTOR PNP SI TO-39 PD=1W FT=100MHZ	28480	1853-0038
A44A1Q2	1884-0009	4	1	THYRISTOR-SCR TO-5 VRRM=200	03508	C6B
A44A1R1	0698-3450	9	1	RESISTOR 42.2K 1% .125W F TC=0+100	24546	C4-1/8-T0-4222-F
A44A1R2	0698-3452	1	1	RESISTOR 147K 1% .125W F TC=0+100	24546	C4-1/8-T0-1473-F
A44A1R3	0757-0279	0	1	RESISTOR 3.16K 1% .125W F TC=0+100	24546	C4-1/8-T0-3161-F
A44A1R4	2100-1986	9	1	RESISTOR-TRMR 1K 10% C TOP-ADJ 1-TRN	73138	82PR1K
A44A1R5	0698-3153	9	1	RESISTOR 3.83K 1% .125W F TC=0+100	24546	C4-1/8-T0-3831-F
A44A1R6	0757-0199	3	1	RESISTOR 21.5K 1% .125W F TC=0+100	24546	C4-1/8-T0-2152-F
A44A1R7	0757-0280	3	2	RESISTOR 1K 1% .125W F TC=0+100	24546	C4-1/8-T0-1001-F
A44A1R8	0757-0442	9	2	RESISTOR 10K 1% .125W F TC=0+100	24546	C4-1/8-T0-1002-F
A44A1R9	0757-0442	9	2	RESISTOR 10K 1% .125W F TC=0+100	24546	C4-1/8-T0-1002-F
A44A1TP1	0360-0535	0	6	TERMINAL TEST POINT PCB	00000	ORDER BY DESCRIPTION
A44A1TP2	0360-0535	0	0	TERMINAL TEST POINT PCB	00000	ORDER BY DESCRIPTION
A44A1TP3	0360-0535	0	0	TERMINAL TEST POINT PCB	00000	ORDER BY DESCRIPTION
A44A1TP4	0360-0535	0	0	TERMINAL TEST POINT PCB	00000	ORDER BY DESCRIPTION
A44A1TP5	0360-0535	0	0	TERMINAL TEST POINT PCB	00000	ORDER BY DESCRIPTION
A44A1TP6	0360-0535	0	0	TERMINAL TEST POINT PCB	00000	ORDER BY DESCRIPTION
A44A1VR1	1902-0579	3	2	DIODE-ZNR 5.1V 5% PD=1W IR=10UA	28480	1902-0579
A44A1VR2	1902-0579	3	2	DIODE-ZNR 5.1V 5% PD=1W IR=10UA	28480	1902-0579
A44A1VR3	1902-3404	9	1	DIODE-ZNR 82.5V 5% DO-7 PD=.4W TC=+.082%	28480	1902-3404
A44A1W1	1460-1489	8	1	WIREFORM BE CU AG	28480	1460-1489
A44MP1	5001-1559	5	1	INSULATOR	28480	5001-1559
A44MP2	2360-0115	4	2	SCREW-MACH 6-32 .312-IN-LG PAN-HD-POZI	00000	ORDER BY DESCRIPTION

See introduction to this section for ordering information
 *Indicates factory selected value

Table 6-3. Replaceable Parts

Reference Designation	HP Part Number	C D	Qty	Description	Mfr Code	Mfr Part Number
A45	0955-0098		1	DIRECTIONAL COUPLER (ORDER THE REPLACEMENT KIT BELOW IF INSTRUMENT IS EQUIPPED WITH A 5086-7305 OR 5086-6305 PRE- LEVELER. INSTRUMENTS WITH A SERIAL PREFIX OF 2405A OR BELOW WERE ORIGINALLY EQUIPPED WITH A PRELEVELER	28480	0955-0098
	08340-60207	B	1	REPLACEMENT KIT FOR 5086-7305 (AND 5086-6305) PRELEVELER. (INCLUDES DIRECTIONAL COUPLER, 15 DB ATTENUATOR, AND REQUIRED CABLES)	28480	08340-60207

See Introduction to this section for ordering information.

*Indicates factory-related value.

Table 6-3. Replaceable Parts

Reference Designation	HP Part Number	C D	Qty	Description	Mfr Code	Mfr Part Number
A46	9135-0165	4	1	7.0 GBZ LOW PASS FILTER	28480	9135-0165
A47	08340-60094	1	1	SENSE RESISTOR ASSEMBLY	28480	08340-60094
NOTE See Figure 6-1 for mechanical parts location.						
A47C1	0160-4835	7	1	CAPACITOR-FXD .1UF ±10% 50VDC CER	28480	0160-4835
A47MP1	0340-0162	7	1	INSULATOR-XSTR ALUMINUM	28480	0340-0162
A47MP2	08340-60128	2	1	CBL AY SEN RES S	28480	08340-60128
A47MP3	0360-0268	6	1	TERMINAL-SLDR LUG LK-MTG FOR-#6-SCR	28480	0360-0268
A47MP4	08340-60129	3	1	CBL AY SEN RES L	28480	08340-60129
A47MP5	0400-0009	9	1	GROMMET-RND .125-IN-ID .25-IN-GRV-OD	28480	0400-0009
A47MP6	0400-0011	3	2	GROMMET-RND .375-IN-ID .5-IN-GRV-OD	28480	0400-0011
A47MP7	0400-0011	3		GROMMET-RND .375-IN-ID .5-IN-GRV-OD	28480	0400-0011
A47MP8	0520-0127	6	10	SCREW-MACH 2-56 .188-IN-LG PAN-HD-POZI	00000	ORDER BY DESCRIPTION
A47MP9	0520-0127	6		SCREW-MACH 2-56 .188-IN-LG PAN-HD-POZI	00000	ORDER BY DESCRIPTION
A47MP10	0520-0127	6		SCREW-MACH 2-56 .188-IN-LG PAN-HD-POZI	00000	ORDER BY DESCRIPTION
A47MP11	0520-0127	6		SCREW-MACH 2-56 .188-IN-LG PAN-HD-POZI	00000	ORDER BY DESCRIPTION
A47MP12	0520-0127	6		SCREW-MACH 2-56 .188-IN-LG PAN-HD-POZI	00000	ORDER BY DESCRIPTION
A47MP13	0520-0127	6		SCREW-MACH 2-56 .188-IN-LG PAN-HD-POZI	00000	ORDER BY DESCRIPTION
A47MP14	0520-0127	6		SCREW-MACH 2-56 .188-IN-LG PAN-HD-POZI	00000	ORDER BY DESCRIPTION
A47MP15	0520-0127	6		SCREW-MACH 2-56 .188-IN-LG PAN-HD-POZI	00000	ORDER BY DESCRIPTION
A47MP16	0520-0127	6		SCREW-MACH 2-56 .188-IN-LG PAN-HD-POZI	00000	ORDER BY DESCRIPTION
A47MP17	0520-0127	6		SCREW-MACH 2-56 .188-IN-LG PAN-HD-POZI	00000	ORDER BY DESCRIPTION
A47MP18	0624-0305	2	4	SCREW-TPG 6-20 .5-IN-LG PAN-HD-POZI	00000	ORDER BY DESCRIPTION
A47MP19	0624-0305	2		SCREW-TPG 6-20 .5-IN-LG PAN-HD-POZI	00000	ORDER BY DESCRIPTION
A47MP20	0624-0305	2		SCREW-TPG 6-20 .5-IN-LG PAN-HD-POZI	00000	ORDER BY DESCRIPTION
A47MP21	0624-0305	2		SCREW-TPG 6-20 .5-IN-LG PAN-HD-POZI	00000	ORDER BY DESCRIPTION
A47MP22	0890-0094	9	1	TUBING-FLEX .051-ID TFE .016-WALL	00000	ORDER BY DESCRIPTION
A47MP23	1200-0043	8	1	INSULATOR-XSTR ALUMINUM	28480	1200-0043
A47MP24	1200-0456	7	1	SOCKET-XSTR 2-CONT TO-3	28480	1200-0456
A47MP25	1200-0457	8	1	SOCKET-XSTR 2-CONT TO-66	28480	1200-0457
A47MP26-28	2190-0006	1	3	WASHER-LK HLCL NO. 6 .141-IN-ID	28480	2190-0006
A47MP29	2190-0014	1	10	WASHER-LK INTL T NO. 2 .089-IN-ID	28480	2190-0014
A47MP30	2190-0014	1		WASHER-LK INTL T NO. 2 .089-IN-ID	28480	2190-0014
A47MP31	2190-0014	1		WASHER-LK INTL T NO. 2 .089-IN-ID	28480	2190-0014
A47MP32	2190-0014	1		WASHER-LK INTL T NO. 2 .089-IN-ID	28480	2190-0014
A47MP33	2190-0014	1		WASHER-LK INTL T NO. 2 .089-IN-ID	28480	2190-0014
A47MP34	2190-0014	1		WASHER-LK INTL T NO. 2 .089-IN-ID	28480	2190-0014
A47MP35	2190-0014	1		WASHER-LK INTL T NO. 2 .089-IN-ID	28480	2190-0014
A47MP36	2190-0014	1		WASHER-LK INTL T NO. 2 .089-IN-ID	28480	2190-0014
A47MP37	2190-0014	1		WASHER-LK INTL T NO. 2 .089-IN-ID	28480	2190-0014
A47MP38	2190-0014	1		WASHER-LK INTL T NO. 2 .089-IN-ID	28480	2190-0014
A47MP39	2200-0103	2	2	SCREW-MACH 4-40 .25-IN-LG PAN-HD-POZI	00000	ORDER BY DESCRIPTION
A47MP40	2200-0103	2		SCREW-MACH 4-40 .25-IN-LG PAN-HD-POZI	00000	ORDER BY DESCRIPTION
A47MP41	2360-0113	2	2	SCREW-MACH 6-32 .25-IN-LG PAN-HD-POZI	00000	ORDER BY DESCRIPTION
A47MP42	2360-0113	2		SCREW-MACH 6-32 .25-IN-LG PAN-HD-POZI	00000	ORDER BY DESCRIPTION
A47MP43	2360-0203	1	4	SCREW-MACH 6-32 .625-IN-LG PAN-HD-POZI	00000	ORDER BY DESCRIPTION
A47MP44	2360-0203	1		SCREW-MACH 6-32 .625-IN-LG PAN-HD-POZI	00000	ORDER BY DESCRIPTION
A47MP45	2360-0203	1		SCREW-MACH 6-32 .625-IN-LG PAN-HD-POZI	00000	ORDER BY DESCRIPTION
A47MP46	2360-0203	1		SCREW-MACH 6-32 .625-IN-LG PAN-HD-POZI	00000	ORDER BY DESCRIPTION
A47MP47	3050-0003	3	4	WASHER-FL NM NO. 6 .141-IN-ID .375-IN-OD	28480	3050-0003
A47MP48	3050-0003	3		WASHER-FL NM NO. 6 .141-IN-ID .375-IN-OD	28480	3050-0003
A47MP49	3050-0003	3		WASHER-FL NM NO. 6 .141-IN-ID .375-IN-OD	28480	3050-0003
A47MP50	3050-0003	3		WASHER-FL NM NO. 6 .141-IN-ID .375-IN-OD	28480	3050-0003
A47MP51	3050-0005	5	4	WASHER-SHLDR NO. 6 .14-IN-ID .375-IN-OD	28480	3050-0005
A47MP52	3050-0005	5		WASHER-SHLDR NO. 6 .14-IN-ID .375-IN-OD	28480	3050-0005
A47MP53	3050-0005	5		WASHER-SHLDR NO. 6 .14-IN-ID .375-IN-OD	28480	3050-0005
A47MP54	3050-0005	5		WASHER-SHLDR NO. 6 .14-IN-ID .375-IN-OD	28480	3050-0005
A47MP55	3050-0227	3	4	WASHER-FL MTLN NO. 6 .149-IN-ID	28480	3050-0227
A47MP56	3050-0227	3		WASHER-FL MTLN NO. 6 .149-IN-ID	28480	3050-0227
A47MP57	3050-0227	3		WASHER-FL MTLN NO. 6 .149-IN-ID	28480	3050-0227
A47MP58	3050-0227	3		WASHER-FL MTLN NO. 6 .149-IN-ID	28480	3050-0227
A47MP59	6960-0016	0	4	PLUG-HOLE TR-HD FOR .125-D-HOLE NYL	28480	6960-0016
A47MP60	6960-0016	0		PLUG-HOLE TR-HD FOR .125-D-HOLE NYL	28480	6960-0016
A47MP61	6960-0016	0		PLUG-HOLE TR-HD FOR .125-D-HOLE NYL	28480	6960-0016
A47MP62	6960-0016	0		PLUG-HOLE TR-HD FOR .125-D-HOLE NYL	28480	6960-0016
A47MP63	08340-00033	2	1	BCKT CURRNT SENS	28480	08340-00033
A47MP64	08340-00046	7	1	BOX-CURRNT SENS	28480	08340-00046
A47MP65	08340-00048	9	1	MTG PLATE	28480	08340-00048
A47Q1	1854-0237	7	1	TRANSISTOR NPN SI TO-66 PD=20W FT=10MHZ	28480	1854-0237
A47Q2	1854-0080	8	1	TRANSISTOR NPN SI TO-3 PD=100MW FT=300 MHZ	02037	SJ1515

See introduction to this section for ordering information
*Indicates factory selected value

Table 6-3. Model 8340A Replaceable Parts

Reference Designation	HP Part Number	C D	Qty	Description	Mfr Code	Mfr Part Number
A47R1	0811-3571	7	4	RESISTOR 60 1% 12W PW TC=0+2	28480	0811-3571
A47R2	0811-3571	7		RESISTOR 60 1% 12W PW TC=0+2	28480	0811-3571
A47R3	0811-3571	7		RESISTOR 60 1% 12W PW TC=0+2	28480	0811-3571
A47R4	0811-3571	7		RESISTOR 60 1% 12W PW TC=0+2	28480	0811-3571
A47R5	0811-1100	4	1	RESISTOR 3 1% 12W PW TC=0+5	28480	0811-1100
A47R6	0811-3597	7	1	RESISTOR 97.5 .25% 25W PW TC = 0 +2	28480	0811-3597
A47W1	08340-60128	2	1	CBL AY SEN RES S	28480	08340-60128
A47W2	08340-60129	3	1	CBL AY SEN RES L	28480	08340-60129
A47W3	8151-0010	1	1	WIRE 16AWG 1X16	28480	8151-0010

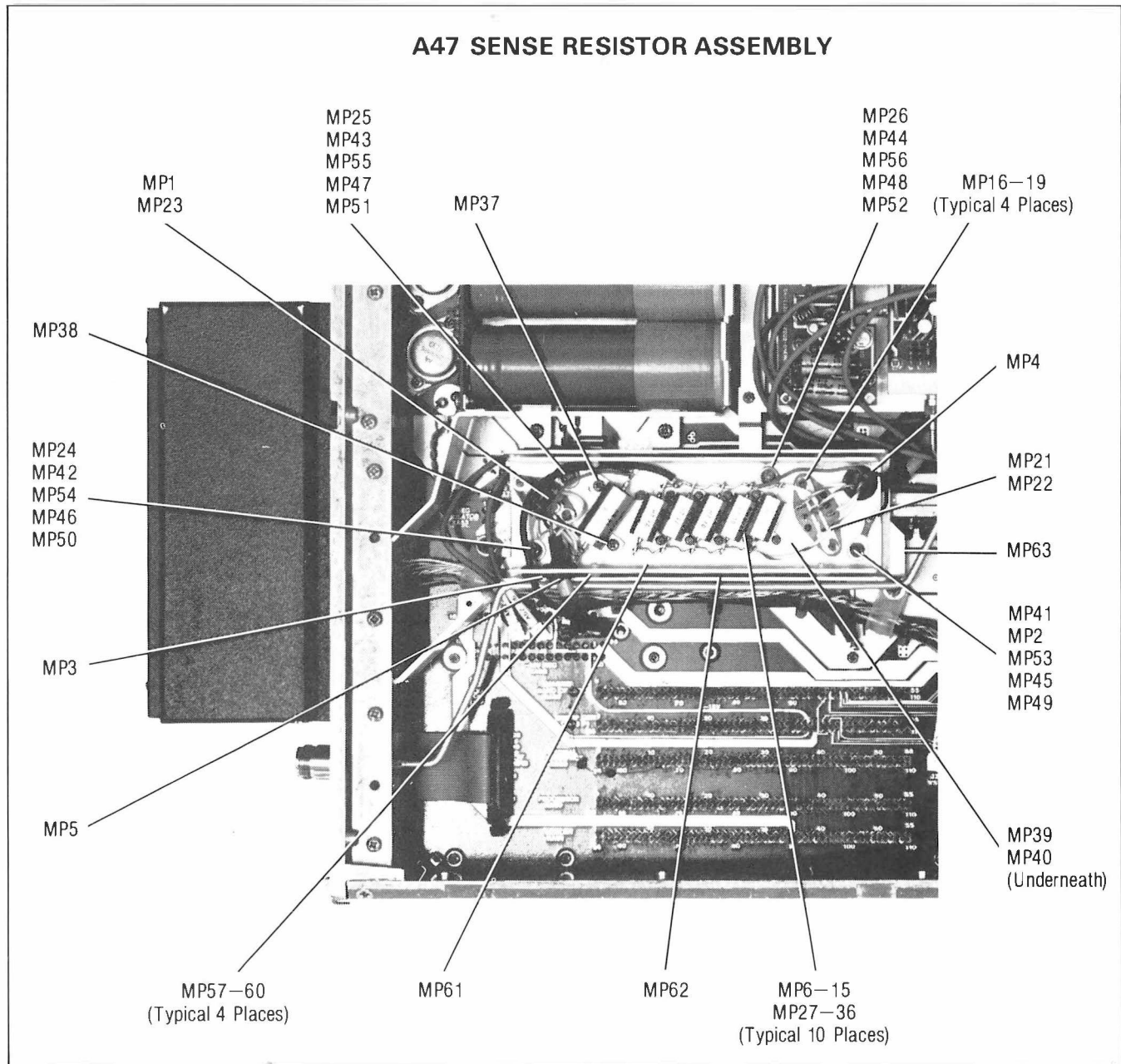

Figure 6-1. A47 Sense Resistor Assembly Mechanical Parts Location

Table 6-3. Replaceable Parts

Reference Designation	HP Part Number	C D	Qty	Description	Mfr Code	Mfr Part Number
A48	08340-60028	1	1	SAMPLER AMPIIFIER, NOT SEPERATELY REPLACEABLE, ORDER 08340-60177 (INCLUDES A48, A49, AND HOUSING)		
A48C1	0121-0046	2	2	CAPACITOR-V TRMR-CER 9-35PF 200V PC-MTG	52763	304322 9/35PF N650
A48C2	0121-0046	2	2	CAPACITOR-V TRMR-CER 9-35PF 200V PC-MTG	52763	304322 9/35PF N650
A48C3	0180-0197	8	2	CAPACITOR-FXD 2.2UF+10% 20VDC TA	56289	150D225X9020A2
A48C4	0180-0116	1	1	CAPACITOR-FXD 6.8UF±10% 35VDC TA	56289	150D685X9035B2
A48C5	0160-2055	9	11	CAPACITOR-FXD .01UF +80-20% 100VDC CER	28480	0160-2055
A48C6	0160-2150	5	1	CAPACITOR-FXD 33PF +5% 300VDC MICA	28480	0160-2150
A48C7	0160-2055	9		CAPACITOR-FXD .01UF +80-20% 100VDC CER	28480	0160-2055
A48C8	0160-3878	6	3	CAPACITOR-FXD 1000PF +20% 100VDC CER	28480	0160-3878
A48C9	0180-0197	8		CAPACITOR-FXD 2.2UF+10% 20VDC TA	56289	150D225X9020A2
A48C10	0160-2264	2	1	CAPACITOR-FXD 20PF ±5% 500VDC CER 0+30	28480	0160-2264
A48C11	0160-3878	6		CAPACITOR-FXD 1000PF +20% 100VDC CER	28480	0160-3878
A48C12	0160-2055	9		CAPACITOR-FXD .01UF +80-20% 100VDC CER	28480	0160-2055
A48C13	0180-0228	6	1	CAPACITOR-FXD 22UF+10% 15VDC TA	56289	150D226X9015B2
A48C14	0160-2055	9		CAPACITOR-FXD .01UF +80-20% 100VDC CER	28480	0160-2055
A48C15	0160-2055	9		CAPACITOR-FXD .01UF +80-20% 100VDC CER	28480	0160-2055
A48C16				NOT ASSIGNED		
A48C17	0160-2055	9		CAPACITOR-FXD .01UF +80-20% 100VDC CER	28480	0160-2055
A48C18	0160-3878	6		CAPACITOR-FXD 1000PF +20% 100VDC CER	28480	0160-3878
A48C19	0160-3879	7	4	CAPACITOR-FXD .01UF ±20% 100VDC CER	28480	0160-3879
A48C20	0160-0939	4	1	CAPACITOR-FXD 430PF ±5% 300VDC MICA	28480	0160-0939
A48C21	0160-2055	9		CAPACITOR-FXD .01UF +80-20% 100VDC CER	28480	0160-2055
A48C22	0140-0195	2	1	CAPACITOR-FXD 130PF +5% 300VDC MICA	72136	DM15F131J0300WV1CR
A48C23	0160-2055	9		CAPACITOR-FXD .01UF +80-20% 100VDC CER	28480	0160-2055
A48C24	0140-0193	0	2	CAPACITOR-FXD 82PF +5% 300VDC MICA	72136	DM15E820J0300WV1CR
A48C25	0140-0193	0		CAPACITOR-FXD 82PF ±5% 300VDC MICA	72136	DM15E820J0300WV1CR
A48C26	0160-2308	5	1	CAPACITOR-FXD 36PF +5% 300VDC MICA	28480	0160-2308
A48C27	0160-2055	9		CAPACITOR-FXD .01UF +80-20% 100VDC CER	28480	0160-2055
A48C28	0160-2055	9		CAPACITOR-FXD .01UF +80-20% 100VDC CER	28480	0160-2055
A48C29	0160-3879	7		CAPACITOR-FXD .01UF +20% 100VDC CER	28480	0160-3879
A48C30	0160-3879	7		CAPACITOR-FXD .01UF ±20% 100VDC CER	28480	0160-3879
A48C31	0160-2055	9		CAPACITOR-FXD .01UF +80-20% 100VDC CER	28480	0160-2055
A48C32	0160-3879	7		CAPACITOR-FXD .01UF ±20% 100VDC CER	28480	0160-3879
A48E1	1251-3172	7	3	CONNECTOR-SGL CONT SKT .03-IN-BSC-SZ RND	28480	1251-3172
A48E2	1251-3172	7		CONNECTOR-SGL CONT SKT .03-IN-BSC-SZ RND	28480	1251-3172
A48E3	1251-3172	7		CONNECTOR-SGL CONT SKT .03-IN-BSC-SZ RND	28480	1251-3172
A48J1				SEE "MISCELLANEOUS YO LOOP PARTS" AT THE END OF TABLE 6-3.		
A48J2				SEE "MISCELLANEOUS YO LOOP PARTS" AT THE END OF TABLE 6-3.		
A48L1				STRIP LINE ON P.C. BOARD		
A48L2	9140-0144	0	1	INDUCTOR RF-CH-MLD 4.7UH 10% .105DX.26LG	28480	9140-0144
A48L3	9100-1623	8	1	INDUCTOR RF-CH-MLD 27UH 5% .166DX.385LG	28480	9100-1623
A48L4	9100-2251	0	1	INDUCTOR RF-CH-MLD 220NH 10% .105DX.26LG	28480	9100-2251
A48L5	9100-2258	7	2	INDUCTOR RF-CH-MLD 1.2UH 10% .105DX.26LG	28480	9100-2258
A48L6	9100-2258	7		INDUCTOR RF-CH-MLD 1.2UH 10% .105DX.26LG	28480	9100-2258
A48L7	9135-0073	3	1	INDUCTOR RF-CH-MLD 51NH 6% .102DX.26LG (RECOMMENDED REPLACEMENT)	28480	9135-0073
A48L8, 9				STRIP LINE ON P. C. BOARD		
A48L10	9140-0539	7	1	INDUCTOR RF-CH-MLD 3UH 5% .105DX.26LG	28480	9140-0539
A48L11	9100-0368	6	1	INDUCTOR RF-CH-MLD 330NH 10% .105DX.26LG	28480	9100-0368
A48L12	9100-2249	6	2	INDUCTOR RF-CH-MLD 150NH 10% .105DX.26LG	28480	9100-2249
A48L13	9100-2250	9	1	INDUCTOR RF-CH-MLD 180NH 10% .105DX.26LG	28480	9100-2250
A48L14	9100-2249	6		INDUCTOR RF-CH-MLD 150NH 10% .105DX.26LG	28480	9100-2249
A48MP1				NOT ASSIGNED		
A48MP2	1205-0011	0	2	HEAT SINK TO-5/TO-39-CS	28480	1205-0011
A48MP3				NOT ASSIGNED		
A48MP4				NOT ASSIGNED		
A48MP5	1205-0011	0		HEAT SINK TO-5/TO-39-CS	28480	1205-0011
A48MP6, 7	4330-0145	9	2	INSULATOR-BEAD GLASS	28480	4330-0145
A48Q1	1854-0247	9	3	TRANSISTOR NPN SI TO-39 PD=1W FT=800MHZ	28480	1854-0247
A48Q2	1854-0345	8	3	TRANSISTOR NPN 2N5179 SI TO-72 PD=200MW	04713	2N5179
A48Q3	1854-0247	9		TRANSISTOR NPN SI TO-39 PD=1W FT=800MHZ	28480	1854-0247
A48Q4	1855-0235	7	1	TRANSISTOR J-FET N-CHAN D-MODE TO-52 SI	28480	1855-0235
A48Q5	1853-0015	7	1	TRANSISTOR PNP SI PD=200MW FT=500MHZ	28480	1853-0015
A48Q6	1854-0345	8		TRANSISTOR NPN 2N5179 SI TO-72 PD=200MW	04713	2N5179
A48Q7	1854-0345	8		TRANSISTOR NPN 2N5179 SI TO-72 PD=200MW	04713	2N5179
A48Q8	1854-0247	9		TRANSISTOR NPN SI TO-39 PD=1W FT=800MHZ	28480	1854-0247

See introduction to this section for ordering information
 *Indicates factory selected value

Table 6-3. Replaceable Parts

Reference Designation	HP Part Number	C D	Qty	Description	Mfr Code	Mfr Part Number
NOTE						
A48R1, R28, AND R29 MUST BE REPLACED AT THE SAME TIME						
A48R1	2100-3212	8	1	RESISTOR-TRMR 200 10% C TOP-ADJ 1-TRN (RECOMMENDED REPLACEMENT)	28480	2100-3212
A48R2	0757-0394	0	5	RESISTOR 51.1 1% .125W F TC=0+100	24546	C4-1/8-T0-51R1-F
A48R3	0698-3440	7	1	RESISTOR 196 1% .125W F TC=0+100	24546	C4-1/8-T0-196R-F
A48R4	0698-0085	0	1	RESISTOR 2.61K 1% .125W F TC=0+100	24546	C4-1/8-T0-2611-F
A48R5	0757-0424	7	3	RESISTOR 1.1K 1% .125W F TC=0+100	24546	C4-1/8-T0-1101-F
A48R6	0757-0280	3	3	RESISTOR 1K 1% .125W F TC=0+100	24546	C4-1/8-T0-1001-F
A48R7	0757-0278	9	1	RESISTOR 1.78K 1% .125W F TC=0+100	24546	C4-1/8-T0-1781-F
A48R8	0757-0796	6	1	RESISTOR 82.5 1% .5W F TC=0+100	28480	0757-0796
A48R9	0757-0399	5	1	RESISTOR 82.5 1% .125W F TC=0+100	24546	C4-1/8-T0-82R5-F
A48R10	0698-3457	6	1	RESISTOR 316K 1% .125W F TC=0+100	28480	0698-3457
A48R11	0757-0470	3	1	RESISTOR 162K 1% .125W F TC=0+100	24546	C4-1/8-T0-1623-F
A48R12				NOT ASSIGNED		
A48R13	0698-7216	3	1	RESISTOR 147 1% .05W F TC=0+100	24546	C3-1/8-T0-147R-F
A48R14				NOT ASSIGNED		
A48R15	0757-0424	7		RESISTOR 1.1K 1% .125W F TC=0+100	24546	C4-1/8-T0-1101-F
A48R16	0757-0398	4	1	RESISTOR 75 1% .125W F TC=0+100	24546	C4-1/8-T0-75R0-F
A48R17	0757-0424	7		RESISTOR 1.1K 1% .125W F TC=0+100	24546	C4-1/8-T0-1101-F
A48R18	0757-0419	0	1	RESISTOR 681 1% .125W F TC=0+100	24546	C4-1/8-T0-681R-F
A48R19	0757-0421	4	1	RESISTOR 825 1% .125W F TC=0+100	24546	C4-1/8-T0-825R-F
A48R20	0698-7224	3	1	RESISTOR 316 1% .05W F TC=0+100	24546	C3-1/8-T0-316R-F
A48R21	0698-7212	9	1	RESISTOR 100 1% .05W F TC=0+100	24546	C3-1/8-T0-100R-F
A48R22	0698-7195	7	1	RESISTOR 19.6 1% .05W F TC=0+100	24546	C3-1/8-T0-19R6-F
A48R23	0698-0083	8	1	RESISTOR 1.96K 1% .125W F TC=0+100	24546	C4-1/8-T0-1961-F
A48R24	0698-0084	9	1	RESISTOR 2.15K 1% .125W F TC=0+100	24546	C4-1/8-T0-2151-F
A48R25	0698-0082	7	1	RESISTOR 464 1% .125W F TC=0+100	24546	C4-1/8-T0-4640-F
A48R26	0757-0280	3		RESISTOR 1K 1% .125W F TC=0+100	24546	C4-1/8-T0-1001-F
A48R27	0757-0394	0		RESISTOR 51.1 1% .125W F TC=0+100	24546	C4-1/8-T0-51R1-F
A48R28	0698-3438	3	1	RESISTOR 147 1% .125W F TC=0+100 (RECOMMENDED REPLACEMENT)	24546	C4-1/8-T0-147R-F
A48R29	0698-3447	4	1	RESISTOR 422 1% .125W F TC=0+100 (RECOMMENDED REPLACEMENT)	24546	C3-1/8-T0-422R-F
A48R30	0757-0346	2	2	RESISTOR 10 1% .125W F TC=0+100	24546	C4-1/8-T0-10R0-F
A48R31	0757-0420	3	1	RESISTOR 750 1% .125W F TC=0+100	24546	C4-1/8-T0-751-F
A48R32	0698-3439	4	2	RESISTOR 178 1% .125W F TC=0+100	24546	C4-1/8-T0-178R-F
A48R33	0757-0346	2		RESISTOR 10 1% .125W F TC=0+100	24546	C4-1/8-T0-10R0-F
A48R34	0757-0280	3		RESISTOR 1K 1% .125W F TC=0+100	24546	C4-1/8-T0-1001-F
A48R35	0698-3439	4		RESISTOR 178 1% .125W F TC=0+100	24546	C4-1/8-T0-178R-F
A48R36	0757-0394	0		RESISTOR 51.1 1% .125W F TC=0+100	24546	C4-1/8-T0-51R1-F
A48R37	0757-0394	0		RESISTOR 51.1 1% .125W F TC=0+100	24546	C4-1/8-T0-51R1-F
A48R38	0757-0276	7	2	RESISTOR 61.9 1% .125W F TC=0+100	24546	C4-1/8-T0-6192-F
A48R39	0757-0276	7		RESISTOR 61.9 1% .125W F TC=0+100	24546	C4-1/8-T0-6192-F
A48R40	0757-0189	2		RESISTOR 31.6 1% .125W F TC=0+100	24546	C4-1/8-T0-31R6-F
A48R41	0698-7196	8	1	RESISTOR 21.5 1% .05W F TC=0+100	24546	C3-1/8-T0-21R5-F
A48R42	0757-0294	9	1	RESISTOR 17.8 1% .125W F TC=0+100	24546	C4-1/8-T0-17R8-F
A48TP1	0360-0535	0	1	TERMINAL TEST POINT PCB	00000	ORDER BY DESCRIPTION
A48U1	5086-7292	3	1	SAMPLER	28480	5086-7292

See introduction to this section for ordering information
 *Indicates factory selected value

Table 6-3. Replaceable Parts

Reference Designation	HP Part Number	C D	Qty	Description	Mfr Code	Mfr Part Number
A49	08340-60180	6	1	YO LOOP PHASE DETECTOR, NOT SEPERATELY REPLACEABLE, ORDER 08340-60177 (INCLUDES A48, A49, AND HOUSING)	28480	08340-60180
A49C1	0160-4805	1	2	CAPACITOR-FXD 47PF +5% 100VDC CER 0+30	28480	0160-4805
A49C2	0160-4805	1		CAPACITOR-FXD 47PF +5% 100VDC CER 0+30	28480	0160-4805
A49C3	0160-4526	3	1	CAPACITOR-FXD 42PF +5% 200VDC CER 0+30	28480	0160-4526
A49C4	0160-4767	4	1	CAPACITOR-FXD 20PF +5% 200VDC CER 0+30	28480	0160-4767
A49C5	0160-4918	7		CAPACITOR-FXD .022UF +10% 50VDC CER	28480	0160-4918
A49C6	0160-4832	4	8	CAPACITOR-FXD .01UF +10% 100VDC CER	28480	0160-4832
A49C7	0160-4918	7		CAPACITOR-FXD .022UF +10% 50VDC CER	28480	0160-4918
A49C8	0160-4832	4		CAPACITOR-FXD .01UF +10% 100VDC CER	28480	0160-4832
A49C9	0180-0116	1	1	CAPACITOR-FXD 6.8UF+10% 35VDC TA	56289	150D685X9035B2
A49C10	0180-0197	8	2	CAPACITOR-FXD 2.2UF+10% 20VDC TA	56289	150D225X9020A2
A49C11	0160-4918	7	4	CAPACITOR-FXD .022UF +10% 50VDC CER	28480	0160-4918
A49C12	0160-4918	7		CAPACITOR-FXD .022UF +10% 50VDC CER	28480	0160-4918
A49C13	0180-0197	8		CAPACITOR-FXD 2.2UF+10% 20VDC TA	56289	150D225X9020A2
A49C14	0160-4835	7	1	CAPACITOR-FXD .1UF +10% 50VDC CER	28480	0160-4835
A49C15	0160-4932	5	2	CAPACITOR-FXD 750PF +5% 100VDC CER	28480	0160-4932
A49C16	0160-4932	5		CAPACITOR-FXD 750PF +5% 100VDC CER	28480	0160-4932
A49C17	0160-4832	4		CAPACITOR-FXD .01UF +10% 100VDC CER	28480	0160-4832
A49C18	0160-4832	4		CAPACITOR-FXD .01UF +10% 100VDC CER	28480	0160-4832
A49C19	0160-0162	5	1	CAPACITOR-FXD .022UF +10% 200VDC POLYE	28480	0160-0162
A49C20	0160-4787	8	3	CAPACITOR-FXD 22PF +5% 100VDC CER 0+30	28480	0160-4787
A49C21	0160-2290	4	1	CAPACITOR-FXD .15UF +10% 80VDC POLYE	28480	0160-2290
A49C22	0160-4787	8		CAPACITOR-FXD 22PF +5% 100VDC CER 0+30	28480	0160-4787
A49C23	0160-0164	7	1	CAPACITOR-FXD .039UF +10% 200VDC POLYE	28480	0160-0164
A49C24	0160-3405	5	1	CAPACITOR-FXD 2UF +10% 50VDC MET-POLYC	28480	0160-3405
A49C25	0160-4535	4	2	CAPACITOR-FXD 1UF +10% 50VDC CER	28480	0160-4535
A49C26	0160-4535	4		CAPACITOR-FXD 1UF +10% 50VDC CER	28480	0160-4535
A49C27	0160-4787	8		CAPACITOR-FXD 22PF +5% 100VDC CER 0+30	28480	0160-4787
A49C28	0160-4832	4		CAPACITOR-FXD .01UF +10% 100VDC CER	28480	0160-4832
A49C29	0160-4832	4		CAPACITOR-FXD .01UF +10% 100VDC CER	28480	0160-4832
A49C30	0160-4835	7		CAPACITOR-FXD .1UF +10% 50VDC CER	28480	0160-4835
A49C31	0160-4835	7		CAPACITOR-FXD .1UF +10% 50VDC CER	28480	0160-4835
A49C32	0160-4835	7		CAPACITOR-FXD .1UF +10% 50VDC CER	28480	0160-4835
A49C33	0160-4832	4		CAPACITOR-FXD .01UF +10% 100VDC CER	28480	0160-4832
A49C34	0160-4832	4		CAPACITOR-FXD .01UF +10% 100VDC CER	28480	0160-4832
A49CR1	1901-0033	2	6	DIODE-GEN PRP 180V 200MA DO-7	28480	1901-0033
A49CR2	1901-0033	2		DIODE-GEN PRP 180V 200MA DO-7	28480	1901-0033
A49CR3	1901-0033	2		DIODE-GEN PRP 180V 200MA DO-7	28480	1901-0033
A49CR4	1901-0033	2		DIODE-GEN PRP 180V 200MA DO-7	28480	1901-0033
A49CR5	1901-0033	2		DIODE-GEN PRP 180V 200MA DO-7	28480	1901-0033
A49CR6	1901-0033	2		DIODE-GEN PRP 180V 200MA DO-7	28480	1901-0033
A49CR7	1901-1098	1	2	DIODE-SWITCHING 1N4150 50V 200MA 4NS	28480	1901-1098
A49CR8	1901-1098	1		DIODE-SWITCHING 1N4150 50V 200MA 4NS	28480	1901-1098
A49E1	1251-4932	9	2	CONNECTOR-SGL CONT SKT .021-IN-BSC-SZ	91506	LSG-1AG14-1
A49E2	1251-4932	9		CONNECTOR-SGL CONT SKT .021-IN-BSC-SZ	91506	LSG-1AG14-1
A49J1	1250-0258	2	2	CONNECTOR-RF SMB M SGL-HOLE-FR 50-OHM	28480	1250-0258
A49J2	1250-0258	2		CONNECTOR-RF SMB M SGL-HOLE-FR 50-OHM	28480	1250-0258
A49J3	1250-0691	7	2	CONNECTOR-RF SMB M SGL-HOLE-FR 50-OHM	28480	1250-0691
A49J4	1250-0691	7		CONNECTOR-RF SMB M SGL-HOLE-FR 50-OHM	28480	1250-0691
A49J5	1250-1889	7	2	CONNECTOR-RF SMB M PC 50-OHM	28480	1250-1889
A49J6	1250-1889	7		CONNECTOR-RF SMB M PC 50-OHM	28480	1250-1889
A49L1	9100-0368	6	2	INDUCTOR RF-CH-MLD 330NH 10% .105DX.26LG	28480	9100-0368
A49L2	9100-2254	3	2	INDUCTOR RF-CH-MLD 390NH 10% .105DX.26LG	28480	9100-2254
A49L3	9100-2254	3		INDUCTOR RF-CH-MLD 390NH 10% .105DX.26LG	28480	9100-2254
A49L4	9100-0368	6		INDUCTOR RF-CH-MLD 330NH 10% .105DX.26LG	28480	9100-0368
A49L5	9100-1641	0	2	INDUCTOR RF-CH-MLD 240UH 5% .166DX.385LG	28480	9100-1641
A49L6	9100-1620	5	3	INDUCTOR RF-CH-MLD 15UH 10% .166DX.385LG	28480	9100-1620
A49L7	9100-1641	0		INDUCTOR RF-CH-MLD 240UH 5% .166DX.385LG	28480	9100-1641
A49L8	9100-1620	5		INDUCTOR RF-CH-MLD 15UH 10% .166DX.385LG	28480	9100-1620
A49L9	9100-1620	5		INDUCTOR RF-CH-MLD 15UH 10% .166DX.385LG	28480	9100-1620
A49Q1	1854-0404	0	2	TRANSISTOR NPN SI TO-18 PD=360MW	28480	1854-0404
A49Q2	1854-0404	0		TRANSISTOR NPN SI TO-18 PD=360MW	28480	1854-0404
A49Q3	1854-0475	5	1	TRANSISTOR-DUAL NPN PD=750MW	28480	1854-0475
A49R1	0698-7212	9	4	RESISTOR 100 1% .05W F TC=0+100	24546	C3-1/8-TO-100R-F
A49R2	0698-7212	9		RESISTOR 100 1% .05W F TC=0+100	24546	C3-1/8-TO-100R-F
A49R3	0698-7219	6	2	RESISTOR 196 1% .05W F TC=0+100	24546	C3-1/8-TO-196R-F
A49R4	0757-0401	0	8	RESISTOR 100 1% .125W F TC=0+100	24546	C4-1/8-TO-101-F
A49R5	0698-7212	9		RESISTOR 100 1% .05W F TC=0+100	24546	C3-1/8-TO-100R-F
A49R6	0698-7219	6		RESISTOR 196 1% .05W F TC=0+100	24546	C3-1/8-TO-196R-F

See introduction to this section for ordering information
 *Indicates factory selected value

Table 6-3. Replaceable Parts

Reference Designation	HP Part Number	C D	Qty	Description	Mfr Code	Mfr Part Number
A49R7	0698-3122	2	2	RESISTOR 412 1% .125W F TC=0+100	03888	PME55-1/8-T0-4120-F
A49R8	0698-3122	2		RESISTOR 412 1% .125W F TC=0+100	03888	PME55-1/8-T0-4120-F
A49R9	0698-3440	7	2	RESISTOR 196 1% .125W F TC=0+100	24546	C4-1/8-T0-196R-F
A49R10	0698-3440	7		RESISTOR 196 1% .125W F TC=0+100	24546	C4-1/8-T0-196R-F
A49R11	0757-0438	3	3	RESISTOR 5.11K 1% .125W F TC=0+100	24546	C4-1/8-T0-5111-F
A49R12	0698-3445	2	2	RESISTOR 348 1% .125W F TC=0+100	24546	C4-1/8-T0-348R-F
A49R13	0698-3445	2		RESISTOR 348 1% .125W F TC=0+100	24546	C4-1/8-T0-348R-F
A49R14	0698-3154	0	1	RESISTOR 4.22K 1% .125W F TC=0+100	24546	C4-1/8-T0-4221-F
A49R15	0757-0442	9	1	RESISTOR 10K 1% .125W F TC=0+100	24546	C4-1/8-T0-1002-F
A49R16	0698-3156	2	1	RESISTOR 14.7K 1% .125W F TC=0+100	24546	C4-1/8-T0-1472-F
A49R17	0757-0278	9	1	RESISTOR 1.78K 1% .125W F TC=0+100	24546	C4-1/8-T0-1781-F
A49R18	0757-0317	7	2	RESISTOR 1.33K 1% .125W F TC=0+100	24546	C4-1/8-T0-1331-F
A49R19	0698-0085	0	2	RESISTOR 2.61K 1% .125W F TC=0+100	24546	C4-1/8-T0-2611-F
A49R20	0757-0288	1	2	RESISTOR 9.09K 1% .125W F TC=0+100	19701	MF4C1/8-T0-9091-F
A49R21	0698-7236	7	1	RESISTOR 1K 1% .05W F TC=0+100	24546	C3-1/8-T0-1001-F
A49R22	0698-7277	6	1	RESISTOR 51.1K 1% .05W F TC=0+100	24546	C3-1/8-T0-5112-F
A49R23	0698-3155	1	1	RESISTOR 4.64K 1% .125W F TC=0+100	24546	C4-1/8-T0-4641-F
A49R24	0698-7267	4	1	RESISTOR 19.6K 1% .05W F TC=0+100	24546	C3-1/8-T0-1962-F
A49R25	0757-0416	7	4	RESISTOR 511 1% .125W F TC=0+100	24546	C4-1/8-T0-511R-F
A49R26	0757-0416	7		RESISTOR 511 1% .125W F TC=0+100	24546	C4-1/8-T0-511R-F
A49R27	0698-4020	1	1	RESISTOR 9.53K 1% .125W F TC=0+100	24546	C4-1/8-T0-9531-F
A49R28	0698-0085	0		RESISTOR 2.61K 1% .125W F TC=0+100	24546	C4-1/8-T0-2611-F
A49R29	0757-0438	3		RESISTOR 5.11K 1% .125W F TC=0+100	24546	C4-1/8-T0-5111-F
A49R30	0757-0440	7	1	RESISTOR 7.5K 1% .125W F TC=0+100	24546	C4-1/8-T0-7501-F
A49R31	0757-0317	7		RESISTOR 1.33K 1% .125W F TC=0+100	24546	C3-1/8-T0-1331-F
A49R32	0698-7241	4	2	RESISTOR 1.62K 1% .05W F TC=0+100	24546	C3-1/8-T0-1621-F
A49R33	0698-7241	4		RESISTOR 1.62K 1% .05W F TC=0+100	24546	C3-1/8-T0-1621-F
A49R34	0757-0288	1		RESISTOR 9.09K 1% .125W F TC=0+100	19701	MF4C1/8-T0-9091-F
A49R35	0757-0403	2	1	RESISTOR 121 1% .125W F TC=0+100	24546	C4-1/8-T0-121R-F
A49R36	0757-0416	7		RESISTOR 511 1% .125W F TC=0+100	24546	C4-1/8-T0-511R-F
A49R37	0757-0346	2	3	RESISTOR 10 1% .125W F TC=0+100	24546	C4-1/8-T0-10R0-F
A49R38	0757-0401	0	1	RESISTOR 100 1% .125W F TC=0+100	24546	C4-1/8-T0-101-F
A49R39	0757-0401	0		RESISTOR 100 1% .125W F TC=0+100	24546	C4-1/8-T0-101-F
A49R40	0757-0401	0		RESISTOR 100 1% .125W F TC=0+100	24546	C4-1/8-T0-101-F
A49R41	0757-0401	0		RESISTOR 100 1% .125W F TC=0+100	24546	C4-1/8-T0-101-F
A49R42	0757-0401	0		RESISTOR 100 1% .125W F TC=0+100	24546	C4-1/8-T0-101-F
A49R43	0757-0401	0		RESISTOR 100 1% .125W F TC=0+100	24546	C4-1/8-T0-101-F
A49R44	0757-0401	0		RESISTOR 100 1% .125W F TC=0+100	24546	C4-1/8-T0-101-F
A49R45	0698-7273	2	2	RESISTOR 34.8K 1% .05W F TC=0+100	28480	0698-7273
A49R46	0757-0441	8	1	RESISTOR 8.25K 1% .125W F TC=0+100	24546	C4-1/8-T0-8251-F
A49R47	0698-3150	6	1	RESISTOR 2.37K 1% .125W F TC=0+100	28480	0698-3150
A49R48	0698-0438	3		RESISTOR 5.11K 1% .125W F TC=0+100	24546	C4-1/8-T0-5111-F
A49R49	0698-7273	2		RESISTOR 34.8K 1% .05W F TC=0+100	28480	0698-7273
A49R50	0698-3452	1	1	RESISTOR 147K 1% .125W F TC=0+100	28480	0698-3452
A49A51	0698-7212	9		RESISTOR 100 1% .05W F TC=0+100	24546	C4-1/8-T0-100R-F
A49R52	0757-0416	7		RESISTOR 511 1% .125W F TC=0+100	24546	C4-1/8-T0-511R-F
A49R53	0757-0346	2		RESISTOR 10 1% .125W F TC=0+100	24546	C4-1/8-T0-10R0-F
A49R54	0757-0346	2		RESISTOR 10 1% .125W F TC=0+100	24546	C4-1/8-T0-10R0-F
A49TP1	0360-0535	0	5	TERMINAL TEST POINT PCB	00000	ORDER BY DESCRIPTION
A49TP2	0360-0535	0		TERMINAL TEST POINT PCB	00000	ORDER BY DESCRIPTION
A49TP3	0360-0535	0		TERMINAL TEST POINT PCB	00000	ORDER BY DESCRIPTION
A49TP4	0360-0535	0		TERMINAL TEST POINT PCB	00000	ORDER BY DESCRIPTION
A49TP5	0360-0535	0		TERMINAL TEST POINT PCB	00000	ORDER BY DESCRIPTION
A49U1	1826-0783	9	3	IC OP AMP LOW-NOISE 8-DIP-C PKG	52063	XR5534ACN
A49U2	1826-0092	3	1	IC OP AMP GP DUAL TO-99 PKG	02037	SC76551GK
A49U3	1826-1145	9	1	IC AMP LOW-DROOP 14-DIP-C PKG	28480	1826-1145
A49U4	1826-0783	9		IC OP AMP LOW-NOISE 8-DIP-C PKG	52063	XR5534ACN
A49U5	1826-0783	9		IC OP AMP LOW-NOISE 8-DIP-C PKG	52063	XR5534ACN
A49U6	1820-1344	8	1	IC PL LOOP 14-DIP-C PKG	04713	MC12040L
A49U7	1810-0204	6	1	NETWORK-RES 8-SIPL.0K OHM X 7	01121	208A102
A49U8	1820-0802	1	1	IC GATE ECL NOR QUAD 2-INP	04713	MC10102P
A49VR1	1902-1260	1	2	DIODE-ZNR 1N5525C 6.2V 2% DO-7 PD=.4W	04713	1N5525C
A49VR2	1902-1260	1		DIODE-ZNR 1N5525C 6.2V 2% DO-7 PD=.4W	04713	1N5525C
A49VR3	1902-3082	9	1	DIODE-ZNR 4.64V 5% DO-35 PD=.4W	28480	1902-3082
A49VR4	1902-3036	3	2	DIODE-ZNR 3.16V 5% DO-7 PD=.4W TC=-.064%	28480	1902-3036
A49VR5	1902-3036	3		DIODE-ZNR 3.16V 5% DO-7 PD=.4W TC=-.064%	28480	1902-3036
A49W1	1258-0124	7	1	PIN-PROGRAMING DUMPER .30 CONTACT	91506	8136-475G1

See introduction to this section for ordering information
 *Indicates factory selected value

Table 6-3. Replaceable Parts

Reference Designation	HP Part Number	C D	Qty	Description	Mfr Code	Mfr Part Number
A50	08340-60030	5	1	YO LOOP INTERCONNECT	28480	08340-60030
A50C1	0180-2614	8	3	CAPACITOR-FXD 100UF+10% 30VDC TA	56289	150D107X9030S2
A50C2	0160-4835	7	2	CAPACITOR-FXD .1UF ±10% 50VDC CER	28480	0160-4835
A50C3	0160-4835	7		CAPACITOR-FXD .1UF ±10% 50VDC CER	28480	0160-4835
A50C4	0180-2614	8		CAPACITOR-FXD 100UF±10% 30VDC TA	56289	150D107X9030S2
A50C5	0180-2614	8		CAPACITOR-FXD 100UF±10% 30VDC TA	56289	150D107X9030S2
A50C6, 7				NOT ASSIGNED		
A50C8	0160-3036	8	8	CAPACITOR-FDTHRU 5000PF +80 -20% 200V	28480	0160-3036
A50C9	0160-3036	8		CAPACITOR-FDTHRU 5000PF +80 -20% 200V	28480	0160-3036
A50C10	0160-3036	8		CAPACITOR-FDTHRU 5000PF +80 -20% 200V	28480	0160-3036
A50C11	0160-3036	8		CAPACITOR-FDTHRU 5000PF +80 -20% 200V	28480	0160-3036
A50C12	0160-3036	8		CAPACITOR-FDTHRU 5000PF +80 -20% 200V	28480	0160-3036
A50C13	0160-3036	8		CAPACITOR-FDTHRU 5000PF +80 -20% 200V	28480	0160-3036
A50C14	0160-3036	8		CAPACITOR-FDTHRU 5000PF +80 -20% 200V	28480	0160-3036
A50C15	0160-3036	8		CAPACITOR-FDTHRU 5000PF +80 -20% 200V	28480	0160-3036
A50DS1	1990-0485	5	1	LED-LAMP LUM-INT=800UCD IF=30MA-MAX	28480	5082-4984
A50L1	9100-2262	3	1	INDUCTOR RF-CH-MLD 3.9UH 10% .105DX.26LG	28480	9100-2262
A50L2	9100-1618	1	4	INDUCTOR RF-CH-MLD 5.6UH 10%	28480	9100-1618
A50L3	9100-1618	1		INDUCTOR RF-CH-MLD 5.6UH 10%	28480	9100-1618
A50L4	9100-1618	1		INDUCTOR RF-CH-MLD 5.6UH 10%	28480	9100-1618
A50L5	9100-1618	1		INDUCTOR RF-CH-MLD 5.6UH 10%	28480	9100-1618
A50R1	0757-0280	3	4	RESISTOR 1K 1% .125W F TC=0+100	24546	C4-1/8-T0-1001-F
A50R2	0757-0280	3		RESISTOR 1K 1% .125W F TC=0+100	24546	C4-1/8-T0-1001-F
A50R3	0757-0442	9	1	RESISTOR 10K 1% .125W F TC=0+100	24546	C4-1/8-T0-1002-F
A50R4	0757-0416	7	1	RESISTOR 511 1% .125W F TC=0+100	24546	C4-1/8-T0-511R-F
A50R5	0757-0280	3		RESISTOR 1K 1% .125W F TC=0+100	24546	C4-1/8-T0-1001-F
A50R6	0757-0280	3		RESISTOR 1K 1% .125W F TC=0+100	24546	C4-1/8-T0-1001-F
A50TP1	0360-2050	8	10	TEST POINT	28480	0360-2050
A50TP2	0360-2050	8		TEST POINT	28480	0360-2050
A50TP3	0360-2050	8		TEST POINT	28480	0360-2050
A50TP4	0360-2050	8		TEST POINT	28480	0360-2050
A50TP5	0360-2050	8		TEST POINT	28480	0360-2050
A50TP6	0360-2050	8		TEST POINT	28480	0360-2050
A50TP7	0360-2050	8		TEST POINT	28480	0360-2050
A50TP8	0360-2050	8		TEST POINT	28480	0360-2050
A50TP9	0360-2050	8		TEST POINT	28480	0360-2050
A50TP10	0360-2050	8		TEST POINT	28480	0360-2050
A50U1	1858-0047	5	1	TRANSISTOR ARRAY 16-PIN PLSTC DIP	13606	ULN-2003A
A50W1	8120-3120	5	1	CABLE	28480	8120-3120
A50W2	08340-60209	0	1	CABLE RBN 16 PIN (INCLUDES W2P1,P2)	28480	08340-60209
A50X1	1251-2313	6	8	CONNECTOR-SGL CONT SKT .04-IN-BSC-S2 RND	28480	1251-2313
A50X2	1251-2313	6		CONNECTOR-SGL CONT SKT .04-IN-BSC-S2 RND	28480	1251-2313
A50X3	1251-2313	6		CONNECTOR-SGL CONT SKT .04-IN-BSC-S2 RND	28480	1251-2313
A50X4	1251-2313	6		CONNECTOR-SGL CONT SKT .04-IN-BSC-S2 RND	28480	1251-2313
A50X5	1251-2313	6		CONNECTOR-SGL CONT SKT .04-IN-BSC-S2 RND	28480	1251-2313
A50X6	1251-2313	6		CONNECTOR-SGL CONT SKT .04-IN-BSC-S2 RND	28480	1251-2313
A50X7	1251-2313	6		CONNECTOR-SGL CONT SKT .04-IN-BSC-S2 RND	28480	1251-2313
A50X8	1251-2313	6		CONNECTOR-SGL CONT SKT .04-IN-BSC-S2 RND	28480	1251-2313

See introduction to this section for ordering information
 *Indicates factory selected value

Table 6-3. Replaceable Parts

Reference Designation	HP Part Number	C D	Qty	Description	Mfr Code	Mfr Part Number
A51	08340-60183	9	1	10 MHZ REFERENCE OSCILLATOR	28480	08340-60183
	0960-0477	1	1	CRYSTAL OSCILLATOR FREQ. = 10.00 MHZ	28480	0960-0477
	08340-60246	5	1	CABLE 10MHZ FREQ STD	28480	08340-60246

See introduction to this section for ordering information.

*Indicates factory selected value.

Table 6-3. Replaceable Parts

Reference Designation	HP Part Number	C D	Qty	Description	Mfr Code	Mfr Part Number
A52	08340-60179	3	1	POSITIVE REGULATOR	28480	08340-60179
A52C1	0160-5338	7	1	CAPACITOR-FXD .33UF +10% 50VDC CER	28480	0160-5338
A52C2	0180-0116	1	4	CAPACITOR-FXD 6.8UF+10% 35VDC TA	56289	150D685X9035B2
A52C3	0160-4807	3	1	CAPACITOR-FXD 33PF ±5% 100VDC CER 0+30	28480	0160-4807
A52C4	0180-1746	5	2	CAPACITOR-FXD 15UF+10% 20VDC TA	56289	150D156X9020B2
A52C5	0180-0228	6	3	CAPACITOR-FXD 22UF±10% 15VDC TA	56289	150D226X9015B2
A52C6	0180-0116	1		CAPACITOR-FXD 6.8UF+10% 35VDC TA	56289	150D685X9035B2
A52C7	0180-1746	5		CAPACITOR-FXD 15UF+10% 20VDC TA	56289	150D156X9020B2
A52C8	0160-4005	3		CAPACITOR-FXD 1UF+20% 100VDC CER	28480	0160-4005
A52C9	0160-4835	7	1	CAPACITOR-FXD .1UF +10% 50VDC CER	28480	0160-4835
A52C10	0180-2811	7		CAPACITOR-FXD 10UF±20% 35VDC TA	28480	0180-2811
A52C11	0160-4834	6	1	CAPACITOR-FXD .047UF +10% 100VDC CER	28480	0160-4834
A52C12	0160-4005	3	1	CAPACITOR-FXD 1UF +20% 100VDC CER	28480	0160-4005
A52C13	0180-2617	1	1	CAPACITOR-FXD 6.8UF +10% 35VDC TA	28480	0180-2617
A52C14	0180-0228	6		CAPACITOR-FXD 22UF+10% 15VDC TA	56289	150D226X9015B2
A52C15	0180-0228	6		CAPACITOR-FXD 22UF±10% 15VDC TA	56289	150D226X9015B2
A52C16	0160-4386	3	1	CAPACITOR-FXD 33PF +5% 200VDC CER 0+30	28480	0160-4386
A52C17	0180-0116	1		CAPACITOR-FXD 6.8UF±10% 35VDC TA	56289	150D685X9035B2
A52C18	0180-0116	1		CAPACITOR-FXD 6.8UF+10% 35VDC TA	56289	150D685X9035B2
A52C19	0160-4832	4	1	CAPACITOR-FXD .01UF +10% 100VDC CER	28480	0160-4832
A52C20-22	0160-4084	8	3	CAPACITOR-FXD .1UF +20% 50VDC CER	28480	0160-4084
A52CR1-3				NOT ASSIGNED		
A52CR4	1901-0033	2	9	DIODE-GEN PRP 180V 200MA DO-7	28480	1901-0033
A52CR5	1901-0033	2		DIODE-GEN PRP 180V 200MA DO-7	28480	1901-0033
A52CR6	1901-0033	2		DIODE-GEN PRP 180V 200MA DO-7	28480	1901-0033
A52CR7	1901-0033	2		DIODE-GEN PRP 180V 200MA DO-7	28480	1901-0033
A52CR8	1901-0033	2		DIODE-GEN PRP 180V 200MA DO-7	28480	1901-0033
A52CR9	1901-0033	2		DIODE-GEN PRP 180V 200MA DO-7	28480	1901-0033
A52CR10	1901-0662	3	4	DIODE-PWR RECT 100V 6A	04713	MR751
A52CR11	1901-0662	3		DIODE-PWR RECT 100V 6A	04713	MR751
A52CR12	1901-0662	3		DIODE-PWR RECT 100V 6A	04713	MR751
A52CR13	1901-0033	2		DIODE-GEN PRP 180V 200MA DO-7	28480	1901-0033
A52CR14	1901-0033	2		DIODE-GEN PRP 180V 200MA DO-7	28480	1901-0033
A52CR15	1901-0033	2		DIODE-GEN PRP 180V 200MA DO-7	28480	1901-0033
A52CR16	1901-0662	3		DIODE-PWR RECT 100V 6A	04713	MR751
A52DS1-3	1990-0487	7	3	LED-LAMP LUM-INT=LMCD IF=20MA-MAX BVR=5V	28480	5082-4584
A52DS4	1990-0486	6	1	LED-LAMP LUM-INT=LMCD IF=20MA-MAX BVR=5V	28480	5082-4684
A52F1	2110-0618	3	1	FUSE 5A 125V NTD .25X.27	28480	2110-0618
A52F2	2110-0332	8	1	FUSE 3A 125V .25X.27	28480	2110-0332
A52F3	2110-0249	6	1	FUSE 12A 250V NTD 1.25X.25 UL	28480	2110-0249
A52MP1	08340-20073	2	1	MTG BLOCK DIODE	28480	08340-20073
A52MP2	0520-0129	8	1	SCREW-MACH 2-56 .312-IN-LG PAN-HD-POZI	00000	ORDER BY DESCRIPTION
A52MP3	2190-0014	1	1	WASHER-LK INTL T NO. 2 .089-IN-ID	28480	2190-0014
A52MP4	2950-0014	3	1	NUT-HEX-DBL-CHAM 1/4-28-THD .219-IN-THK	00000	ORDER BY DESCRIPTION
A52MP5	5040-6847	6	1	EXTRACTOR, RED	28480	5040-6847
A52MP6,7	1251-2313	6	4	CONN. SGL CONN.	28480	1251-2313
A52MP8				NOT ASSIGNED		
A52MP9	1251-2313	6		CONN.SGL CONN.	28480	1251-2313
A52MP10	5000-9043	6	1	PIN:P.C. BOARD EXTRACTOR	28480	5000-9043
A52MP11	2110-0643	4	1	FUSEHOLDER-CLIP TYPE 15A 250 V	28480	2110-0643
A52MP12				NOT ASSIGNED		
A52MP13	8150-0014	3	1	WIRE 22AWG BL 300V PVC 7X30 105C	28480	8150-0014
A52MP14	2190-0027	6	1	WASHER-LK INTL T 1/4 IN .256-IN-ID	28480	2190-0027
A52Q1	1884-0018	5	2	THYRISTOR-SCR 2N4186 VRRM=200	04713	2N4186
A52Q2	1884-0018	5		THYRISTOR-SCR 2N4186 VRRM=200	04713	2N4186
A52Q3	1854-0477	7	4	TRANSISTOR NPN 2N2222A SI TO-18 PD=500MW	04713	2N2222A
A52Q4	1854-0477	7		TRANSISTOR NPN 2N2222A SI TO-18 PD=500MW	04713	2N2222A
A52Q5	1853-0213	7	1	TRANSISTOR PNP 2N4236 SI TO-5 PD=1W	04713	2N4236
A52Q6	1854-0404	0	3	TRANSISTOR NPN SI TO-18 PD=360MW	28480	1854-0404
A52Q7	1854-0404	0		TRANSISTOR NPN SI TO-18 PD=360MW	28480	1854-0404
A52Q8	1854-0404	0		TRANSISTOR NPN SI TO-18 PD=360MW	28480	1854-0404
A52Q9	1854-0477	7		TRANSISTOR NPN 2N2222A SI TO-18 PD=500MW	04713	2N2222A
A52Q10	1854-0441	5	1	TRANSISTOR NPN SI PD=5.8W FT=800KHZ	28480	1854-0441
A52Q11	1884-0046	9	1	THYRISTOR-SCR VRRM=50	03508	C230F
A52Q12	1854-0637	1	1	TRANSISTOR NPN 2N2219A SI TO-5 PD=800MW	01295	2N2219A
A52Q13	1853-0281	9	1	TRANSISTOR PNP 2N2907A SI TO-18 PD=400MW	04713	2N2907A
A52Q14	1853-0314	9	1	TRANSISTOR PNP 2N2905A SI TO-39 PD=600MW	04713	2N2905A
A52Q15	1854-0477	7		TRANSISTOR NPN 2N2222A SI TO-18 PD=500MW	04713	2N2222A
A52Q16	1853-0034	0	1	TRANSISTOR PNP SI TO-18 PD=360MW	28480	1853-0034
A52R1	0812-0021	8	1	RESISTOR .47 5% 3W PW TC = 0+90	91637	CW2B1-3-T-27/100-J
A52R2	0811-4507	1	1	RESISTOR .56 5% 3W PW TC = 0+90	28480	0811-4507

See introduction to this section for ordering information
 *Indicates factory selected value

Table 6-3. Replaceable Parts

Reference Designation	HP Part Number	C D	Qty	Description	Mfr Code	Mfr Part Number
A52R3	0811-4506	0	3	RESISTOR .27 5% 3W PW TC = 0 +90	28480	0811-4506
A52R4	0811-4506	0		RESISTOR .27 5% 3W PW TC = 0 +90	28480	0811-4506
A52R5	0811-4506	0		RESISTOR .27 5% 3W PW TC = 0 +90	28480	0811-4506
A52R6	0757-0401	0	7	RESISTOR 100 1% .125W F TC = 0 +100	24546	C4-1/8-T0-101-F
A52R7	0757-0401	0		RESISTOR 100 1% .125W F TC = 0 +100	24546	C4-1/8-T0-101-F
A52R8	0757-0416	7	3	RESISTOR 511 1% .125W F TC = 0 +100	24546	C4-1/8-T0-511R-F
A52R9	0757-0442	9	7	RESISTOR 10K 1% .125W F TC = 0 +100	24546	C4-1/8-T0-1002-F
A52R10	0757-0394	0	1	RESISTOR 51.1 1% .125W F TC = 0 +100	24546	C4-1/8-T0-51R1-F
A52R11	0698-3150	6	1	RESISTOR 2.37K 1% .125W F TC = 0 +100	24546	C4-1/8-T0-2371-F
A52R12	0698-3442	9	2	RESISTOR 237 1% .125W F TC = 0 +100	24546	C4-1/8-T0-237R-F
A52R13	0757-0438	3	5	RESISTOR 5.11K 1% .125W F TC = 0 +100	24546	C4-1/8-T0-5111-F
A52R14	0757-0428	1	1	RESISTOR 1.62K 1% .125W F TC = 0 +100	24546	C4-1/8-T0-1621-F
A52R15	0757-0438	3	1	RESISTOR 5.11K 1% .125W F TC = 0 +100	24546	C4-1/8-T0-5111-F
A52R16	0757-0280	3	5	RESISTOR 1K 1% .125W F TC = 0 +100	24546	C4-1/8-T0-1001-F
A52R17	0757-0438	3		RESISTOR 5.11K 1% .125W F TC = 0 +100	24546	C4-1/8-T0-5111-F
A52R18	0698-8817	2	3	RESISTOR 2.61 1% .125W F TC = 0 +100	28480	0698-8817
A52R19	0757-0346	2	3	RESISTOR 10 1% .125W F TC = 0 +100	24546	C4-1/8-T0-10R0-F
A52R20	0698-3444	1	3	RESISTOR 316 1% .125W F TC = 0 +100	24546	C4-1/8-T0-316R-F
A52R21	0698-3447	4	1	RESISTOR 422 1% .125W F TC = 0 +100	24546	C4-1/8-T0-422R-F
A52R22	0757-0440	7	2	RESISTOR 7.5K 1% .125W F TC = 0 +100	24546	C4-1/8-T0-7501-F
A52R23	0757-0442	9	2	RESISTOR 10K 1% .125W F TC = 0 +100	24546	C4-1/8-T0-1002-F
A52R24	0698-3407	6	2	RESISTOR 1.96K 1% .5W F TC = 0 +100	28480	0698-3407
A52R25	0757-0442	9		RESISTOR 10K 1% .125W F TC = 0 +100	24546	C4-1/8-T0-1002-F
A52R26	0698-3407	6		RESISTOR 1.96K 1% .5W F TC = 0 +100	28480	0698-3407
A52R27	0698-3449	6	1	RESISTOR 28.7K 1% .125W F TC = 0 +100	24546	C4-1/8-T0-2872-F
A52R28	0757-0461	2	1	RESISTOR 68.1K 1% .125W F TC = 0 +100	24546	C4-1/8-T0-6812-F
A52R29*	0698-3153	9	1	RESISTOR 3.83K 1% .125W F TC = 0 +100	24546	C4-1/8-T0-3831-F
A52R30	0698-3442	9		RESISTOR 237 1% .125W F TC = 0 +100	24546	C4-1/8-T0-237R-F
A52R31	0698-8817	2		RESISTOR 2.61 1% .125W F TC = 0 +100	28480	0698-8817
A52R32	0698-3444	1		RESISTOR 316 1% .125W F TC = 0 +100	24546	C4-1/8-T0-316R-F
A52R33	0757-0346	2		RESISTOR 10 1% .125W F TC = 0 +100	24546	C4-1/8-T0-10R0-F
A52R34	0698-3445	2	1	RESISTOR 348 1% .125W F TC = 0 +100	24546	C4-1/8-T0-348R-F
A52R35	0757-0440	7		RESISTOR 7.5K 1% .125W F TC = 0 +100	24546	C4-1/8-T0-7501-F
A52R36	0698-0085	0	1	RESISTOR 2.61K 1% .125W F TC = 0 +100	24546	C4-1/8-T0-2611-F
A52R37	0757-0290	5	1	RESISTOR 6.19K 1% .125W F TC = 0 +100	19701	MF4C1/8-T0-6191-F
A52R38	0698-3155	1	1	RESISTOR 4.64K 1% .125W F TC = 0 +100	24546	C4-1/8-T0-4641-F
A52R39	0757-0279	0	4	RESISTOR 3.16K 1% .125W F TC = 0 +100	24546	C4-1/8-T0-3161-F
A52R40	0698-6348	0	1	RESISTOR 3K .1% .125W F TC = 0 +25	28480	0698-6348
A52R41	0698-0084	9	5	RESISTOR 2.15K 1% .125W F TC = 0 +100	24546	C4-1/8-T0-2151-F
A52R42	0698-0084	9		RESISTOR 2.15K 1% .125W F TC = 0 +100	24546	C4-1/8-T0-2151-F
A52R43	0698-0084	9		RESISTOR 2.15K 1% .125W F TC = 0 +100	24546	C4-1/8-T0-2151-F
A52R44	0698-0084	9		RESISTOR 2.15K 1% .125W F TC = 0 +100	24546	C4-1/8-T0-2151-F
A52R45	0698-8827	4	5	RESISTOR 1M 1% .125W F TC = 0 +100	28480	0698-8827
A52R46	0698-8827	4		RESISTOR 1M 1% .125W F TC = 0 +100	28480	0698-8827
A52R47	0698-8827	4		RESISTOR 1M 1% .125W F TC = 0 +100	28480	0698-8827
A52R48	0698-8827	4		RESISTOR 1M 1% .125W F TC = 0 +100	28480	0698-8827
A52R49	0757-0465	6		RESISTOR 100K 1% .125W F TC = 0 +100	24546	C4-1/8-T0-1003-F
A52R50	0698-0083	8	1	RESISTOR 1.96K 1% .125W F TC = 0 +100	24546	C4-1/8-T0-1961-F
A52R51	0757-0416	7		RESISTOR 511 1% .125W F TC = 0 +100	24546	C4-1/8-T0-511R-F
A52R52	0757-0416	7		RESISTOR 511 1% .125W F TC = 0 +100	24546	C4-1/8-T0-511R-F
A52R53	0757-0465	6	1	RESISTOR 100K 1% .125W F TC = 0 +100	24546	C4-1/8-T0-1003-F
A52R54	0757-0442	9		RESISTOR 10K 1% .125W F TC = 0 +100	24546	C4-1/8-T0-1002-F
A52R55	0757-0442	9		RESISTOR 10K 1% .125W F TC = 0 +100	24546	C4-1/8-T0-1002-F
A52R56	0698-8827	4		RESISTOR 1M 1% .125W F TC = 0 +100	28480	0698-8827
A52R57	0698-0084	9		RESISTOR 2.15K 1% .125W F TC = 0 +100	24546	C4-1/8-T0-2151-F
A52R58	0757-0442	9		RESISTOR 10K 1% .125W F TC = 0 +100	24546	C4-1/8-T0-1002-F
A52R59	0757-0438	3		RESISTOR 5.11K 1% .125W F TC = 0 +100	24546	C4-1/8-T0-5111-F
A52R60	0757-0438	3		RESISTOR 5.11K 1% .125W F TC = 0 +100	24546	C4-1/8-T0-5111-F
A52R61	0757-0420	3	1	RESISTOR 750 1% .125W F TC = 0 +100	24546	C4-1/8-T0-751-F
A52R62	0757-0279	0		RESISTOR 3.16K 1% .125W F TC = 0 +100	24546	C4-1/8-T0-3161-F
A52R63	0757-0401	0		RESISTOR 100 1% .125W F TC = 0 +100	24546	C4-1/8-T0-101-F
A52R64	0757-0159	5	1	RESISTOR 1K .5% .5W F TC = 0 +100	28480	0757-0159
A52R65	0698-8466	7	1	RESISTOR 942 .5% .125W F TC = 0 +50	28480	0698-8466
A52R66	0757-0279	0		RESISTOR 3.16K 1% .125W F TC = 0 +100	24546	C4-1/8-T0-3161-F
A52R67	0757-0279	0		RESISTOR 3.16K 1% .125W F TC = 0 +100	24546	C4-1/8-T0-3161-F
A52R68	0698-8464	5	1	RESISTOR 12.6K .5% .125W F TC = 0 +50	28480	0698-8464
A52R69	0698-8817	2		RESISTOR 2.61 1% .125W F TC = 0 +100	28480	0698-8817
A52R70	0698-3444	1		RESISTOR 316 1% .125W F TC = 0 +100	24546	C4-1/8-T0-316R-F
A52R71	0757-0346	2		RESISTOR 10 1% .125W F TC = 0 +100	24546	C4-1/8-T0-10R0-F
A52R72	0698-3443	0	1	RESISTOR 287 1% .125W F TC = 0 +100	24546	C4-1/8-T0-287R-F
A52R73	0698-0090	7	1	RESISTOR 464 1% .5W F TC = 0 +100	28480	0698-0090
A52R74	0757-0401	0		RESISTOR 100 1% .125W F TC = 0 +100	24546	C4-1/8-T0-101-F
A52R75	0757-0401	0		RESISTOR 100 1% .125W F TC = 0 +100	24546	C4-1/8-T0-101-F
A52R76	0757-0401	0		RESISTOR 100 1% .125W F TC = 0 +100	24546	C4-1/8-T0-101-F

See introduction to this section for ordering information
 *Indicates factory selected value

Table 6-3. Replaceable Parts

Reference Designation	HP Part Number	C D	Qty	Description	Mfr Code	Mfr Part Number
A52R77	0757-0401	0		RESISTOR 100 1% .125W F TC = 0 +100	24546	C4-1/8-T0-101-F
A52R78	0757-0280	3		RESISTOR 1K 1% .125W F TC = 0 +100	24546	C4-1/8-T0-1001-F
A52R79	0757-0280	3		RESISTOR 1K 1% .125W F TC = 0 +100	24546	C4-1/8-T0-1001-F
A52R80	0757-0280	3		RESISTOR 1K 1% .125W F TC = 0 +100	24546	C4-1/8-T0-1001-F
A52R81	0757-0280	3		RESISTOR 1K 1% .125W F TC = 0 +100	24546	C4-1/8-T0-1001-F
A52R82	0698-7220	9	1	RESISTOR 215 1% .05W F TC=0+100	28480	0698-7220
A52R83	0698-3437	2	1	RESISTOR 133 1% .125W F TC=0+100	28480	0698-3437
A52TP1	0360-0535	0	7	TERMINAL TEST POINT PCB	00000	ORDER BY DESCRIPTION
A52TP2	0360-0535	0		TERMINAL TEST POINT PCB	00000	ORDER BY DESCRIPTION
A52TP3	0360-0535	0		TERMINAL TEST POINT PCB	00000	ORDER BY DESCRIPTION
A52TP4	0360-0535	0		TERMINAL TEST POINT PCB	00000	ORDER BY DESCRIPTION
A52TP5	0360-0535	0		TERMINAL TEST POINT PCB	00000	ORDER BY DESCRIPTION
A52TP6	0360-0535	0		TERMINAL TEST POINT PCB	00000	ORDER BY DESCRIPTION
A52TP7	0360-0535	0		TERMINAL TEST POINT PCB	00000	ORDER BY DESCRIPTION
A52U1	1820-0223	0	2	IC OP AMP GP TO-99 PKG	3L585	CA301AT
A52U2	1826-0742	0	1	IC V RGLTR-V-REF-FXD 10V T05 PKG	28480	1826-0742
A52U3	1820-0223	0		IC OP AMP GP TO-99 PKG	3L585	CA301AT
A52U4	1826-0138	8	2	IC COMPARATOR GP QUAD 14-DIP-P PKG	01295	LM339N
A52U5	1820-1531	5	1	IC FF CMOS D-TYPE POS-EDGE-TRIG DUAL	3L585	CD4013AF
A52U6	1826-0138	8		IC COMPARATOR GP QUAD 14-DIP-P PKG	01295	LM339N
A52VR1	1902-3252	5	1	DIODE-ZNR 22.6V 2% DO-35 PD=.4W	28480	1902-3252
A52VR2	1902-3193	3	2	DIODE-ZNR 13.3V 5% DO-35 PD=.4W	28480	1902-3193
A52VR3	1902-0049	2	2	DIODE-ZNR 6.19V 5% DO-35 PD=.4W	28480	1902-0049
A52VR4	1902-0041	4	1	DIODE-ZNR 5.11V 5% DO-35 PD=.4W	28480	1902-0041
A52VR5	1902-3160	4	1	DIODE-ZNR 10V 2% DO-35 PD=.4W TC=+.06%	28480	1902-3160
A52VR6	1902-3193	3		DIODE-ZNR 13.3V 5% DO-35 PD=.4W	28480	1902-3193
A52VR7	1902-0049	2		DIODE-ZNR 6.19V 5% DO-35 PD=.4W	28480	1902-0049

See introduction to this section for ordering information
 *Indicates factory selected value

Table 6-3. Model 8340A Replaceable Parts

Reference Designation	HP Part Number	C D	Qty	Description	Mfr Code	Mfr Part Number
A53	08340-60161	4	1	NEGATIVE REGULATOR	28480	08340-60161
A53C1	0160-4807	3	1	CAPACITOR-FXD 33PF +5% 100VDC CER 0+30	28480	0160-4807
A53C2	0160-4804	0		CAPACITOR-FXD 56PF +5% 100VDC CER 0+30	28480	0160-4804
A53C3	0160-4535	4	2	CAPACITOR-FXD 1UF +10% 50VDC CER	28480	0160-4535
A53C4	0160-4834	6	2	CAPACITOR-FXD .047UF +10% 100VDC CER	28480	0160-4834
A53C5	0180-0228	6	2	CAPACITOR-FXD 22UF+10% 15VDC TA	56289	150D226X9015B2
A53C6	0180-1746	5	1	CAPACITOR-FXD 15UF+10% 20VDC TA	56289	150D156X9020B2
A53C7	0180-0291	3	2	CAPACITOR-FXD 1UF+10% 35VDC TA	56289	150D105X9035A2
A53C8	0180-0291	3		CAPACITOR-FXD 1UF+10% 35VDC TA	56289	150D105X9035A2
A53C9				NOT ASSIGNED		
A53C10	0160-4535	4		CAPACITOR-FXD 1UF +10% 50VDC CER	28480	0160-4535
A53C11	0160-4834	6		CAPACITOR-FXD .047UF +10% 100VDC CER	28480	0160-4834
A53C12	0180-0228	6		CAPACITOR-FXD 22UF+10% 15VDC TA	56289	150D226X9015B2
A53C13	0180-2610	4	1	CAPACITOR-FXD 10UF+10% 75VDC TA	00904	T110A106K075AS
A53C14	0180-0374	3	1	CAPACITOR-FXD 10UF+10% 20VDC TA	56289	150D106X9020B2
A53C15, 16	0160-4835	7	2	CAPACITOR-FXD 1UF+10% 50VDC CER	02798	CAC04X7R104K050A
A53CR1	1901-0033	2	9	DIODE-GEN PRP 180V 200MA DO-7	28480	1901-0033
A53CR2	1901-0033	2		DIODE-GEN PRP 180V 200MA DO-7	28480	1901-0033
A53CR3	1901-0033	2		DIODE-GEN PRP 180V 200MA DO-7	28480	1901-0033
A53CR4	1901-1068	5	2	DIODE-SCHOTTKY SM SIG	28480	1901-1068
A53CR5	1901-0033	2		DIODE-GEN PRP 180V 200MA DO-7	28480	1901-0033
A53CR6	1901-0033	2		DIODE-GEN PRP 180V 200MA DO-7	28480	1901-0033
A53CR7	1901-0662	3	4	DIODE-PWR RECT 100V 6A	04713	MR751
A53CR8	1901-0662	3		DIODE-PWR RECT 100V 6A	04713	MR751
A53CR9	1901-0028	5	1	DIODE-PWR RECT 400V 750MA DO-29	28480	1901-0028
A53CR10	1901-0033	2		DIODE-GEN PRP 180V 200MA DO-7	28480	1901-0033
A53CR11	1901-0033	2		DIODE-GEN PRP 180V 200MA DO-7	28480	1901-0033
A53CR12	1901-0662	3		DIODE-PWR RECT 100V 6A	04713	MR751
A53CR13	1901-0033	2		DIODE-GEN PRP 180V 200MA DO-7	28480	1901-0033
A53CR14	1901-0518	8	1	DIODE-SM SIG SCHOTTKY	28480	1901-0518
A53CR15	1901-0033	2		DIODE-GEN PRP 180V 200MA DO-7	28480	1901-0033
A53CR16	1901-0662	3		DIODE-PWR RECT 100V 6A	04713	MR751
A53CR17	1901-1068	5		DIODE-SCHOTTKY SM SIG	28482	1901-1068
A53DS1	1990-0487	7	3	LED-LAMP LUM-INT=LMCD IF=20MA-MAX BVR=5V	28480	5082-4584
A53DS2	1990-0487	7		LED-LAMP LUM-INT=LMCD IF=20MA-MAX BVR=5V	28480	5082-4584
A53DS3	1990-0487	7		LED-LAMP LUM-INT=LMCD IF=20MA-MAX BVR=5V	28480	5082-4584
A53E1	1251-2313	6	4	CONNECTOR-SGL CONT SKT .04-IN-BSC-SZ RND	28480	1251-2313
A53E2	1251-2313	6		CONNECTOR-SGL CONT SKT .04-IN-BSC-SZ RND	28480	1251-2313
A53E3	1251-2313	6		CONNECTOR-SGL CONT SKT .04-IN-BSC-SZ RND	28480	1251-2313
A53E4	1251-2313	6		CONNECTOR-SGL CONT SKT .04-IN-BSC-SZ RND	28480	1251-2313
A53F1	2110-0425	0	1	FUSE 2A 125V .25X.27	28480	2110-0425
A53F2	2110-0332	8	1	FUSE 3A 125V .25X.27	28480	2110-0332
A53F3	2110-0056	3	1	FUSE 6A 250V NTD 1.25X.25 UL IEC	75915	312006
A53MP1	2110-0643	4	1	FUSEHOLDER-CLIP TYPE 15A 250 V	28480	2110-0643
A53MP2	0590-0526	6	1	THREADED INSERT-NUT 4-40 .065-IN-LG SST	28480	0590-0526
A53MP3	2200-0105	4	1	SCREW-MACH 4-40 .312-IN-LG PAN-HD-POZI	00000	ORDER BY DESCRIPTION
A53MP4	5040-6852	3	1	EXTRACTOR, ORANGE	28480	5040-6852
A53MP5	5000-9043	6	1	PIN:P.C. BOARD EXTRACTOR	28480	5000-9043
A53MP6	85662-00029	7	1	HEAT SINK	28480	85662-00029
A53MP7				NOT ASSIGNED		
A53MP8	1205-0011	0	1	HEAT SINK TO-5/TO-39-CS	28480	1205-0011
A53MP9	1200-0173	5		INSULATOR-XSTR DAP-GL	28480	1200-0173
A53Q1	1884-0244	9	1	THYRISTOR-SCR VRRM=400	3L585	S2600D
A53Q2	1854-0404	0	2	TRANSISTOR NPN SI TO-18 PD=360MW	28480	1854-0404
A53Q3	1854-0271	9	1	TRANSISTOR NPN SI TO-39 PD=1W FT=150MHZ	28480	1854-0271
A53Q4	1854-0404	0		TRANSISTOR NPN SI TO-18 PD=360MW	28480	1854-0404
A53Q5	1884-0018	5	2	THYRISTOR-SCR 2N4186 VRRM=200	04713	2N4186
A53Q6	1884-0018	5		THYRISTOR-SCR 2N4186 VRRM=200	04713	2N4186
A53Q7	1854-0477	7	1	TRANSISTOR NPN 2N2222A SI TO-18 PD=500MW	04713	2N2222A
A53R1	0811-1079	6	3	RESISTOR .68 5% 3W PW TC=0+90	91637	CW2B1-3-T2-68/100-J
A53R2	0811-1079	6		RESISTOR .68 5% 3W PW TC=0+90	91637	CW2B1-3-T2-68/100-J
A53R3	0811-1220	9	1	RESISTOR 1.5 5% 3W PW TC=0+50	05524	CW-2B-39
A53R4	0757-0416	7	2	RESISTOR 511 1% .125W F TC=0+100	03292	C4-1/8-T0-511R-F
A53R5	0698-3155	1	1	RESISTOR 4.64K 1% .125W F TC=0+100	03292	C4-1/8-T0-4641-F
A53R6	0757-0401	0	3	RESISTOR 100 1% .125W F TC=0+100	24546	C4-1/8-T0-101-F
A53R7	0757-0159	5	2	RESISTOR 1K 1% .5W F TC=0+100	28480	0757-0159
A53R8	0757-0279	0	5	RESISTOR 3.16K 1% .125W F TC=0+100	24546	C4-1/8-T0-3161-F
A53R9	0757-0279	0		RESISTOR 3.16K 1% .125W F TC=0+100	24546	C4-1/8-T0-3161-F
A53R10	0757-0279	0		RESISTOR 3.16K 1% .125W F TC=0+100	24546	C4-1/8-T0-3161-F
A53R11	0698-8817	2	2	RESISTOR 2.61 1% .125W F TC=0+100	28480	0698-8817
A53R12	0698-3444	1	5	RESISTOR 316 1% .125W F TC=0+100	24546	C4-1/8-T0-316R-F
A53R13	0757-0346	2	3	RESISTOR 10 1% .125W F TC=0+100	24546	C4-1/8-T0-10R0-F

See introduction to this section for ordering information
 *Indicates factory selected value

Table 6-3. Model 8340A Replaceable Parts

Reference Designation	HP Part Number	C D	Qty	Description	Mfr Code	Mfr Part Number
A53R14	0698-3442	9	1	RESISTOR 237 1% .125W F TC=0+100	24546	C4-1/8-T0-237R-F
A53R15	0811-1080	9	2	RESISTOR 2.2 5% 3W PW TC=0+50	28480	0811-1080
A53R16	0698-3444	1		RESISTOR 316 1% .125W F TC=0+100	24546	C4-1/8-T0-316R-F
A53R17	0757-0401	0		RESISTOR 100 1% .125W F TC=0+100	24546	C4-1/8-T0-101-F
A53R18	0811-1080	9		RESISTOR 2.2 5% 3W PW TC=0+50	28480	0811-1080
A53R19	0698-3444	1		RESISTOR 316 1% .125W F TC=0+100	24546	C4-1/8-T0-316R-F
A53R20	0757-0346	2		RESISTOR 10 1% .125W F TC=0+100	24546	C4-1/8-T0-10R0-F
A53R21	0698-3444	1		RESISTOR 316 1% .125W F TC=0+100	24546	C4-1/8-T0-316R-F
A53R22	0811-1079	6	1	RESISTOR .68 5% 3W PW TC=0+90	28480	0811-1079
A53R23	0757-0416	7		RESISTOR 511 1% .125W F TC=0+100	03292	C4-1/8-T0-511R-F
A53R24	0757-0199	3	1	RESISTOR 21.5K 1% .125W F TC=0+100	03292	C4-1/8-T0-2152-F
A53R25	0757-0401	0		RESISTOR 100 1% .125W F TC=0+100	24546	C4-1/8-T0-101-F
A53R26	0757-0159	5		RESISTOR 1K 1% .5W F TC=0+100	28480	0757-0159
A53R27	0757-0279	0		RESISTOR 3.16K 1% .125W F TC=0+100	24546	C4-1/8-T0-3161-F
A53R28	0757-0279	0		RESISTOR 3.16K 1% .125W F TC=0+100	24546	C4-1/8-T0-3161-F
A53R29	0698-8464	5	1	RESISTOR 12.6K .5% .125W F TC=0+50	28480	0698-8464
A53R30	0698-3410	1	1	RESISTOR 3.16K 1% .5W F TC=0+100	28480	0698-3410
A53R31	0698-8817	2		RESISTOR 2.61 1% .125W F TC=0+100	28480	0698-8817
A53R32	0698-3444	1		RESISTOR 316 1% .125W F TC=0+100	24546	C4-1/8-T0-316R-F
A53R33	0757-0346	2		RESISTOR 10 1% .125W F TC=0+100	24546	C4-1/8-T0-10R0-F
A53R34	0757-0420	3	1	RESISTOR 750 1% .125W F TC=0+100	24546	C4-1/8-T0-751-F
A53R35	0698-3132	4	1	RESISTOR 261 1% .125W F TC=0+100	24546	C4-1/8-T0-2610-F
A53R36	0757-0442	9	9	RESISTOR 10K 1% .125W F TC=0+100	24546	C4-1/8-T0-1002-F
A53R37	0757-0442	9		RESISTOR 10K 1% .125W F TC=0+100	24546	C4-1/8-T0-1002-F
A53R38	0698-0084	9	4	RESISTOR 2.15K 1% .125W F TC=0+100	03292	C4-1/8-T0-2151-F
A53R39	0698-8827	4	4	RESISTOR 1M 1% .125W F TC=0+100	03292	CT4
A53R40	0698-0084	9		RESISTOR 2.15K 1% .125W F TC=0+100	03292	C4-1/8-T0-2151-F
A53R41	0698-8827	4		RESISTOR 1M 1% .125W F TC=0+100	03292	CT4
A53R42	0698-0084	9		RESISTOR 2.15K 1% .125W F TC=0+100	03292	C4-1/8-T0-2151-F
A53R43	0698-8827	4		RESISTOR 1M 1% .125W F TC=0+100	03292	CT4
A53R44	0698-0084	9		RESISTOR 2.15K 1% .125W F TC=0+100	03292	C4-1/8-T0-2151-F
A53R45	0698-8827	4		RESISTOR 1M 1% .125W F TC=0+100	03292	CT4
A53R46	0757-0442	9		RESISTOR 10K 1% .125W F TC = 0 +100	24546	C4-1/8-T0-1002-F
A53R47	0757-0465	6	1	RESISTOR 100K 1% .125W F TC=0+100	24546	C4-1/8-T0-1003-F
A53R48	0757-0442	9		RESISTOR 10K 1% .125W F TC=0+100	24546	C4-1/8-T0-1002-F
A53R49	0757-0442	9		RESISTOR 10K 1% .125W F TC=0+100	24546	C4-1/8-T0-1002-F
A53R50	0698-3154	0	1	RESISTOR 4.22K 1% .125W F TC=0+100	24546	C4-1/8-T0-4221-F
A53R51	0757-0442	9		RESISTOR 10K 1% .125W F TC=0+100	24546	C4-1/8-T0-1002-F
A53R52	0757-0280	3		RESISTOR 1K 1% .125W F TC=0+100	24546	C4-1/8-T0-1001-F
A53R53	0757-0280	3		RESISTOR 1K 1% .125W F TC=0+100	24546	C4-1/8-T0-1001-F
A53R54	0757-0280	3		RESISTOR 1K 1% .125W F TC=0+100	24546	C4-1/8-T0-1001-F
A53R55, 56	0757-0274	5	2	RESISTOR 1.21K 1% .125W F TC=0+100	03292	CT4-1/8-T0-1211-F
A53TP1	0360-0535	0	6	TERMINAL TEST POINT PCB	00000	ORDER BY DESCRIPTION
A53TP2	0360-0535	0		TERMINAL TEST POINT PCB	00000	ORDER BY DESCRIPTION
A53TP3	0360-0535	0		TERMINAL TEST POINT PCB	00000	ORDER BY DESCRIPTION
A53TP4	0360-0535	0		TERMINAL TEST POINT PCB	00000	ORDER BY DESCRIPTION
A53TP5	0360-0535	0		TERMINAL TEST POINT PCB	00000	ORDER BY DESCRIPTION
A53TP6	0360-0535	0		TERMINAL TEST POINT PCB	00000	ORDER BY DESCRIPTION
A53U1	1826-0523	5	1	IC 337 V RGLTR TO-3	27014	LM337K
A53U2	1826-0138	8	1	IC COMPARATOR GP QUAD 14-DIP-P PKG	01295	LM339N
A53U3	1820-0223	0	2	IC OP AMP GP TO-99 PKG	3L585	CA301AT
A53U4	1820-0223	0		IC OP AMP GP TO-99 PKG	3L585	CA301AT
A53VR1	1902-3171	7	1	DIODE-ZNR 11V 5% DO-35 PD=.4W TC=+.062%	28480	1902-3171
A53VR2	1902-0049	2	1	DIODE-ZNR 6.19V 5% DO-35 PD=.4W	28480	1902-0049
A53VR3	1902-3330	0	1	DIODE-ZNR 44.2V 2% DO-35 PD=.4W	28480	1902-3330
A53VR4	1902-0025	4	1	DIODE-ZNR 10V 5% DO-35 PD=.4W TC=+.06%	28480	1902-0025
A53VR5	1902-3083	0	1	DIODE-ZNR 4.64V 2% DO-35 PD=.4W	28480	1902-3083
A53VR6	1902-3291	2	1	DIODE-ZNR 31.6V 2% DO-35 PD=.4W	28480	1902-3291
A53VR7	1902-0041	4	1	DIODE-ZNR 5.11V 5% DO-35 PD=.4W	28480	1902-0041
A53VR8	1902-0244	9	1	DIODE-ZNR 30V 5% PD=1W IR=5UA	28480	1902-0244

See introduction to this section for ordering information
 *Indicates factory selected value

Table 6-3. Replaceable Parts

Reference Designation	HP Part Number	C D	Qty	Description	Mfr Code	Mfr Part Number
A54	08340-60016	7	1	YO PRETUNE DAC/DELAY COMPENSATION	28480	08340-60016
A54C1	0160-4535	4	9	CAPACITOR-FXD 1UF +-10% 50VDC CER	28480	0160-4535
A54C2	0160-4535	4		CAPACITOR-FXD 1UF +-10% 50VDC CER	28480	0160-4535
A54C3	0160-4535	4		CAPACITOR-FXD 1UF +-10% 50VDC CER	28480	0160-4535
A54C4	0160-4535	4		CAPACITOR-FXD 1UF +-10% 50VDC CER	28480	0160-4535
A54C5	0160-3670	6	1	CAPACITOR-FXD .1UF +-20% 200VDC CER	28480	0160-3670
A54C6	0160-4535	4		CAPACITOR-FXD 1UF +-10% 50VDC CER	28480	0160-4535
A54C7	0160-4535	4		CAPACITOR-FXD 1UF +-10% 50VDC CER	28480	0160-4535
A54C8	0160-4535	4		CAPACITOR-FXD 1UF +-10% 50VDC CER	28480	0160-4535
A54C9	0160-4535	4		CAPACITOR-FXD 1UF +-10% 50VDC CER	28480	0160-4535
A54C10	0160-4835	7	15	CAPACITOR-FXD .1UF +-10% 50VDC CER	28480	0160-4835
A54C11	0160-3402	2	1	CAPACITOR-FXD 1UF +-5% 50VDC MET-POLYC	28480	0160-3402
A54C12	0160-4835	7		CAPACITOR-FXD .1UF +-10% 50VDC CER	28480	0160-4835
A54C13	0160-4835	7		CAPACITOR-FXD .1UF +-10% 50VDC CER	28480	0160-4835
A54C14				NOT ASSIGNED		
A54C15	0160-4261	3	1	CAPACITOR-FXD .22UF +-10% 50VDC	84411	HEW 249
A54C16	0160-4835	7		CAPACITOR-FXD .1UF +-10% 50VDC CER	28480	0160-4835
A54C17	0160-4835	7		CAPACITOR-FXD .1UF +-10% 50VDC CER	28480	0160-4835
A54C18, 19				NOT ASSIGNED		
A54C20	0160-4835	7		CAPACITOR-FXD .1UF +-10% 50VDC CER	28480	0160-4835
A54C21	0160-4835	7		CAPACITOR-FXD .1UF +-10% 50VDC CER	28480	0160-4835
A54C22	0160-4835	7		CAPACITOR-FXD .1UF +-10% 50VDC CER	28480	0160-4835
A54C23	0160-4832	4	1	CAPACITOR-FXD .01UF +-10% 100VDC CER	28480	0160-4832
A54C24	0160-4835	7		CAPACITOR-FXD .1UF +-10% 50VDC CER	28480	0160-4835
A54C25	0160-4805	1	1	CAPACITOR-FXD 47PF +-5% 100VDC CER 0+-30	28480	0160-4805
A54C26	0160-4574	1	1	CAPACITOR-FXD 1000PF +-10% 100VDC CER	28480	0160-4574
A54C27	0160-4835	7		CAPACITOR-FXD .1UF +-10% 50VDC CER	28480	0160-4835
A54C28	0160-4835	7		CAPACITOR-FXD .1UF +-10% 50VDC CER	28480	0160-4835
A54C29	0160-5098	6	1	CAPACITOR-FXD .22UF +-10% 50VDC CER	16299	CAC05X7R224J050A
A54C30	0160-4835	7		CAPACITOR-FXD .1UF +-10% 50VDC CER	28480	0160-4835
A54C31	0160-4787	8	1	CAPACITOR-FXD 22PF +-5% 100VDC CER 0+-30	28480	0160-4787
A54C32	0160-4835	7		CAPACITOR-FXD .1UF +-10% 50VDC CER	28480	0160-4835
A54C33	0160-4835	7		CAPACITOR-FXD .1UF +-10% 50VDC CER	28480	0160-4835
A54C34	0160-3829	7	1	CAPACITOR-FXD .47UF +-10% 50VDC	28480	0160-3829
A54C35	0160-4535	4		CAPACITOR-FXD 1UF +-10% 50VDC CER	28480	0160-4535
A54C36	0160-4835	7		CAPACITOR-FXD .1UF +-10% 50VDC CER	28480	0160-4835
A54CR1	1901-0033	2	2	DIODE-GEN PRP 180V 200MA DO-7	28480	1901-0033
A54CR2	1901-0033	2		DIODE-GEN PRP 180V 200MA DO-7	28480	1901-0033
A54CR3				NOT ASSIGNED		
A54CR4	1901-0518	8	3	DIODE-SM SIG SCHOTTKY	28480	1901-0518
A54CR5	1901-0518	8		DIODE-SM SIG SCHOTTKY	28480	1901-0518
A54CR6	1901-0518	8		DIODE-SM SIG SCHOTTKY	28480	1901-0518
A54L1	9140-0144	0	5	INDUCTOR RF-CH-MLD 4.7UH 10% .105DX.26LG	28480	9140-0144
A54L2	9140-0144	0		INDUCTOR RF-CH-MLD 4.7UH 10% .105DX.26LG	28480	9140-0144
A54L3	9140-0144	0		INDUCTOR RF-CH-MLD 4.7UH 10% .105DX.26LG	28480	9140-0144
A54L4	9140-0144	0		INDUCTOR RF-CH-MLD 4.7UH 10% .105DX.26LG	28480	9140-0144
A54L5	9140-0144	0		INDUCTOR RF-CH-MLD 4.7UH 10% .105DX.26LG	28480	9140-0144
A54MP1	5040-6848	7	1	EXTRACTOR	28480	5040-6848
A54MP2				NOT ASSIGNED		
A54MP3				NOT ASSIGNED		
A54MP4				NOT ASSIGNED		
A54MP5	1205-0011	0	3	HEAT SINK TO-5/TO-39-CS	28480	1205-0011
A54MP6	1205-0011	0		HEAT SINK TO-5/TO-39-CS	28480	1205-0011
A54MP7	1205-0011	0		HEAT SINK TO-5/TO-39-CS	28480	1205-0011
A54MP8	5000-9043	6	1	PIN.P.C. BOARD EXTRACTOR	28480	5000-9043
A54Q1	1855-0278	8	4	TRANSISTOR J-FET 2N5116 P-CHAN D-MODE	17856	2N5116
A54Q2	1853-0030	4	1	TRANSISTOR PNP SI TO-39 PD=1W FT=100MHZ	28480	1853-0030
A54Q3	1855-0278	8		TRANSISTOR J-FET 2N5116 P-CHAN D-MODE	17856	2N5116
A54Q4	1855-0278	8		TRANSISTOR J-FET 2N5116 P-CHAN D-MODE	17856	2N5116
A54R1	0698-3440	7	2	RESISTOR 196 1% .125W F TC=0+-100	24546	C4-1/8-T0-196R-F
A54R2	0757-0401	0	1	RESISTOR 100 1% .125W F TC=0+-100	24546	C4-1/8-T0-101-F
A54R3	0757-0442	9	10	RESISTOR 10K 1% .125W F TC=0+-100	24546	C4-1/8-T0-1002-F
A54R4	0698-3156	2	2	RESISTOR 14.7K 1% .125W F TC=0+-100	24546	C4-1/8-T0-1472-F
A54R5	0757-0280	3	1	RESISTOR 1K 1% .125W F TC=0+-100	24546	C4-1/8-T0-1001-F
A54R6	0698-3446	3	2	RESISTOR 383 1% .125W F TC=0+-100	24546	C4-1/8-T0-383R-F
A54R7	0698-3145	2	1	RESISTOR 340 1% .125W F TC=0+-100	24546	C4-1/8-T0-340R-F
A54R8	0699-0050	0	1	RESISTOR 5k 1% .1W F TC=0+-5	28480	0699-0050
A54R9	0698-6406	1	1	RESISTOR 8.54K 1% .1W F TC=0+-100	28480	0698-6406
A54R10	0698-3156	2		RESISTOR 14.7K 1% .125W F TC=0+-100	24546	C4-1/8-T0-1472-F
A54R11	0757-0416	7	1	RESISTOR 511 1% .125W F TC=0+-100	24546	C4-1/8-T0-511R-F
A54R12	0757-0442	9		RESISTOR 10K 1% .125W F TC=0+-100	24546	C4-1/8-T0-1002-F
A54R13	0757-0442	9		RESISTOR 10K 1% .125W F TC=0+-100	24546	C4-1/8-T0-1002-F
A54R14	2100-3123	0	1	RESISTOR-TRMR 500 10% C SIDE-ADJ 17-TRN	02111	43P501
A54R15	0757-0346	2	4	RESISTOR 10 1% .125W F TC=0+-100	24546	C4-1/8-T0-10R0-F
A54R16	0757-0346	2	2	RESISTOR 10 1% .125W F TC=0+-100	24546	C4-1/8-T0-10R0-F
A54R17	0757-0346	2	2	RESISTOR 10 1% .125W F TC=0+-100	24546	C4-1/8-T0-10R0-F
A54R18	0757-0346	2	2	RESISTOR 10 1% .125W F TC=0+-100	24546	C4-1/8-T0-10R0-F

See introduction to this manual for ordering information.

*Indicates factory selected value.

Table 6-3. Replaceable Parts

Reference Designation	HP Part Number	C D	Qty	Description	Mfr Code	Mfr Part Number
A54R19	0757-0420	3	1	RESISTOR 750 1% .125W F TC=0+-100	24546	C4-1/8-T0-751-F
A54R20	0699-0797	3	1	RESISTOR 7.65K .1% .1W F TC=0+4	28480	0699-0797
A54R21	0699-0642	7	1	RESISTOR 10K .1% .1W F TC=0+-5	28480	0699-0642
A54R22	2100-3154	7	1	RESISTOR-TRMR 1K 10% C SIDE-ADJ 17-TRN	02111	43P102
A54R23	0698-3446	3	1	RESISTOR 383 1% .125W F TC=0+-100	24546	C4-1/8-T0-383R-F
A54R24	0698-8500	0	1	RESISTOR 16.58K .1% .1W F TC=0+4	28480	0698-8500
A54R25	0699-0747	3	2	RESISTOR 4K .05% .1W F TC=0+-10	28480	0699-0747
A54R26	0699-0747	3	1	RESISTOR 4K .05% .1W F TC=0+-10	28480	0699-0747
A54R27	0698-3430	5	5	RESISTOR 21.5 1% .125W F TC=0+-100	03888	PME55-1/8-T0-21R5-F
A54R28	0698-3430	5	5	RESISTOR 21.5 1% .125W F TC=0+-100	03888	PME55-1/8-T0-21R5-F
A54R29	0757-0442	9	1	RESISTOR 10K 1% .125W F TC=0+-100	24546	C4-1/8-T0-1002-F
A54R30	2100-3161	6	2	RESISTOR-TRMR 20K 10% C SIDE-ADJ 17-TRN	02111	43P203
A54R31	0698-3136	8	2	RESISTOR 17.8K 1% .125W F TC=0+-100	24546	C4-1/8-T0-1782-F
A54R32	2100-3054	6	1	RESISTOR-TRMR 50K 10% C SIDE-ADJ 17-TRN	02111	43P503
A54R33	0757-0199	3	1	RESISTOR 21.5K 1% .125W F TC=0+-100	24546	C4-1/8-T0-2152-F
A54R34	0698-3158	4	1	RESISTOR 23.7K 1% .125W F TC=0+-100	24546	C4-1/8-T0-2372-F
A54R35	0757-0438	3	2	RESISTOR 5.11K 1% .125W F TC=0+-100	24546	C4-1/8-T0-5111-F
A54R36	2100-3161	6	1	RESISTOR-TRMR 20K 10% C SIDE-ADJ 17-TRN	02111	43P203
A54R37	0757-0461	2	2	RESISTOR 68.1K 1% .125W F TC=0+-100	24546	C4-1/8-T0-6812-F
A54R38	0757-0461	2	2	RESISTOR 68.1K 1% .125W F TC=0+-100	24546	C4-1/8-T0-6812-F
A54R39	0757-0442	9	1	RESISTOR 10K 1% .125W F TC=0+-100	24546	C4-1/8-T0-1002-F
A54R40	0757-0442	9	1	RESISTOR 10K 1% .125W F TC=0+-100	24546	C4-1/8-T0-1002-F
A54R41	0757-0438	3	1	RESISTOR 5.11K 1% .125W F TC=0+-100	24546	C4-1/8-T0-5111-F
A54R42	0757-0442	9	1	RESISTOR 10K 1% .125W F TC=0+-100	24546	C4-1/8-T0-1002-F
A54R43	0757-0442	9	1	RESISTOR 10K 1% .125W F TC=0+-100	24546	C4-1/8-T0-1002-F
A54R44				NOT ASSIGNED		
A54R45	0757-0442	9	1	RESISTOR 10K 1% .125W F TC=0+-100	24546	C4-1/8-T0-1002-F
A54R46	0757-0447	4	1	RESISTOR 16.2K 1% .125W F TC=0+-100	24546	C4-1/8-T0-1622-F
A54R47	0757-0442	9	1	RESISTOR 10K 1% .125W F TC=0+-100	24546	C4-1/8-T0-1002-F
A54R48	0698-3136	8	1	RESISTOR 17.8K 1% .125W F TC=0+-100	24546	C4-1/8-T0-1782-F
A54R49	0757-1094	9	1	RESISTOR 1.47K 1% .125W F TC=0+-100	24546	C4-1/8-T0-1471-F
A54R50	0698-3440	7	1	RESISTOR 196 1% .125W F TC=0+-100	24546	C4-1/8-T0-196R-F
A54R51	0698-3430	5	1	RESISTOR 21.5 1% .125W F TC=0+-100	03888	PME55-1/8-T0-21R5-F
A54R52	0698-3430	5	1	RESISTOR 21.5 1% .125W F TC=0+-100	03888	PME55-1/8-T0-21R5-F
A54R53	0698-3430	5	1	RESISTOR 21.5 1% .125W F TC=0+-100	03888	PME55-1/8-T0-21R5-F
A54TP1	0360-0535	0	7	TEST POINT	28480	0360-0535
A54TP2	0360-0535	0	7	TEST POINT	28480	0360-0535
A54TP3	0360-0535	0	7	TEST POINT	28480	0360-0535
A54TP4	0360-0535	0	7	TEST POINT	28480	0360-0535
A54TP5	0360-0535	0	7	TEST POINT	28480	0360-0535
A54TP6	0360-0535	0	7	TEST POINT	28480	0360-0535
A54TP7	0360-0535	0	7	TEST POINT	28480	0360-0535
A54U1	1826-0367	5	1	IC 78M05C V RGLTR TO-39	04713	MC78M05CG
A54U2	1826-0471	2	3	IC OP AMP LOW-DRIFT TO-99 PKG	28480	1826-0471
A54U3	1826-0512	2	1	IC 78M15C V RGLTR TO-39	04713	MC78M15CG
A54U4	1826-0471	2	1	IC OP AMP LOW-DRIFT TO-99 PKG	28480	1826-0471
A54U5	1826-0471	2	1	IC OP AMP LOW-DRIFT TO-99 PKG	28480	1826-0471
A54U6	1826-0308	4	1	IC CONV 12-B-D/A 24-DIP-C PKG	24355	AD562KD/BIN
A54U7	1820-0138	6	1	IC OP AMP GP 14-DIP-C PKG	29632	S52
A54U8	1826-0026	3	1	IC COMPARATOR PRON TO-99 PKG	01295	LM311L
A54U9	1820-1112	8	1	IC FF TTL LS D-TYPE POS-EDGE-TRIG	01295	SN74LS74AN
A54U10	1810-0206	8	2	NETWORK-RES 8-SIP10.0K OHM X 7	01121	208A103
A54U11	1820-1196	8	2	IC FF TTL LS D-TYPE POS-EDGE-TRIG COM	01295	SN74LS174N
A54U12	1810-0206	8	2	NETWORK-RES 8-SIP10.0K OHM X 7	01121	208A103
A54U13	1820-1196	8	2	IC FF TTL LS D-TYPE POS-EDGE-TRIG COM	01295	SN74LS174N
A54U14	1826-0785	1	1	IC OP AMP LOW-BIAS-H-IVIPD DUAL 8-DIP-C	01295	TL072ACJG
A54U15	1826-0798	6	1	IC CONV 8-B-D/A	18324	NE5018F
A54U16	1826-0928	4	1	D/A 8-BIT 22-CERDIP BPLR	02910	NE5118F
A54VR1	1902-0692	1	1	DIODE-ZNR 6.3V 1% DO-7 IPD=4W TC=+.001%	28480	1902-0692

See introduction to this section for ordering information

*Indicates factory selected value

Table 6-3. Replaceable Parts

Reference Designation	HP Part Number	C D	Qty	Description	Mfr Code	Mfr Part Number
A55	08340-60202	6	1	YO DRIVER	28480	08340-60202
A55C1	0180-2140	5	2	CAPACITOR-FXD 5.6UF+-10% 50VDC TA	56289	150D565X9050R2
A55C2	0160-4833	5	1	CAPACITOR-FXD .022UF +-10% 100VDC CER	28480	0160-4833
A55C3	0180-2139	2	1	CAPACITOR-FXD 10UF+-20% 60VDC TA	06001	69F177G7
A55C4	0160-3877	5	1	CAPACITOR-FXD 100PF +-20% 200VDC CER	28480	0160-3877
A55C5				NOT ASSIGNED		
A55C6	0160-4834	6	4	CAPACITOR-FXD .047UF +-10% 100VDC CER	28480	0160-4834
A55C7	0160-4834	6	6	CAPACITOR-FXD .047UF +-10% 100VDC CER	28480	0160-4834
A55C8	0160-0302	5	1	CAPACITOR-FXD .018UF +-10% 200VDC POLYE	28480	0160-0302
A55C9-11				NOT ASSIGNED		
A55C12	0160-4834	6	6	CAPACITOR-FXD .047UF +-10% 100VDC CER	28480	0160-4834
A55C13	0160-4834	6	6	CAPACITOR-FXD .047UF +-10% 100VDC CER	28480	0160-4834
A55C14	0160-4261	3	2	CAPACITOR-FXD .22UF +-10% 50VDC	84411	HEW 249
A55C15	0160-4261	3	3	CAPACITOR-FXD .22UF +-10% 50VDC	84411	HEW 249
A55C16	0160-3879	7	7	CAPACITOR-FXD .01UF +-20% 100VDC CER	28480	0160-3879
A55C17	0160-3879	7	7	CAPACITOR-FXD .01UF +-20% 100VDC CER	28480	0160-3879
A55C18	0160-3879	7	7	CAPACITOR-FXD .01UF +-20% 100VDC CER	28480	0160-3879
A55C19	0160-3879	7	7	CAPACITOR-FXD .01UF +-20% 100VDC CER	28480	0160-3879
A55C20	0180-2140	5	5	CAPACITOR-FXD 5.6UF+-10% 50VDC TA	56289	150D565X9050R2
A55C21	0180-0229	7	1	CAPACITOR-FXD 33UF+-10% 10VDC TA	56289	150D336X9010B2
A55C22	0180-0228	6	1	CAPACITOR-FXD 22UF+-10% 15VDC TA	56289	150D226X9015B2
A55C23	0180-2505	6	2	CAPACITOR-FXD 1UF+-10% 75VDC TA	56289	150D105X9075B2
A55C24	0160-3879	7	7	CAPACITOR-FXD .01UF +-20% 100VDC CER	28480	0160-3879
A55C25	0160-3879	7	7	CAPACITOR-FXD .01UF +-20% 100VDC CER	28480	0160-3879
A55C26	0160-3879	7	7	CAPACITOR-FXD .01UF +-20% 100VDC CER	28480	0160-3879
A55C27-29				NOT ASSIGNED		
A55C30	0180-2505	6	6	CAPACITOR-FXD 1UF+-10% 75VDC TA	56289	150D105X9075B2
A55C31	0180-0230	0	1	CAPACITOR-FXD 1UF+-20% 50VDC TA	56289	150D105X0050A2
A55C32				NOT ASSIGNED		
A55C33	0180-2148	3	1	CAPACITOR-FXD .47UF+-20% 50VDC TA	56289	150D474X0050A2
A55CR1	1901-0033	2	6	DIODE-GEN PRP 180V 200MA DO-7	28480	1901-0033
A55CR2	1901-0033	2	2	DIODE-GEN PRP 180V 200MA DO-7	28480	1901-0033
A55CR3	1901-0033	2	2	DIODE-GEN PRP 180V 200MA DO-7	28480	1901-0033
A55CR4, 5				NOT ASSIGNED		
A55CR6	1901-0033	2	2	DIODE-GEN PRP 180V 200MA DO-7	28480	1901-0033
A55CR7	1901-0033	2	2	DIODE-GEN PRP 180V 200MA DO-7	28480	1901-0033
A55CR8	1901-0033	2	2	DIODE-GEN PRP 180V 200MA DO-7	28480	1901-0033
A55CR9	1901-0050	3	2	DIODE-SWITCHING 80V 200MA 2NS DO-35	28480	1901-0050
A55CR10	1901-0050	3	3	DIODE-SWITCHING 80V 200MA 2NS DO-35	28480	1901-0050
A55MP1	5040-6851	2	1	EXTRACTOR	28480	5040-6851
A55MP2	5000-9043	6	1	PIN:P.C. BOARD EXTRACTOR	28480	5000-9043
A55Q1	1853-0007	7	2	TRANSISTOR PNP 2N3251 SI TO-18 PD=360MW	04713	2N3251
A55Q2	1854-0404	0	1	TRANSISTOR NPN SI TO-18 PD=360MW	28480	1854-0404
A55Q3	1854-0475	5	1	TRANSISTOR-DUAL NPN PD=750MW	28480	1854-0475
A55Q4	1855-0278	8	2	TRANSISTOR J-FET 2N5116 P-CHAN D-MODE	17856	2N5116
A55Q5	1853-0007	7	7	TRANSISTOR PNP 2N3251 SI TO-18 PD=360MW	04713	2N3251
A55Q6	1853-0451	5	2	TRANSISTOR PNP 2N3799 SI TO-18 PD=360MW	01295	2N3799
A55Q7	1854-0404	8	1	TRANSISTOR NPN SI TO-39 PD=700MW	07263	S17643
A55Q8	1853-0451	5	5	TRANSISTOR PNP 2N3799 SI TO-18 PD=360MW	01295	2N3799
A55Q9	1853-0012	4	1	TRANSISTOR PNP 2N2904A SI TO-39 PD=600MW	01295	2N2904A
A55Q10	1853-0038	4	1	TRANSISTOR PNP SI TO-39 PD=1W FT=100MHZ	28480	1853-0038
A55Q11	1855-0278	8	8	TRANSISTOR J-FET 2N5116 P-CHAN D-MODE	17856	2N5116
A55Q12	1854-0232	2	1	TRANSISTOR NPN SI TO-39 PD=1W FT=15MHZ	28480	1854-0232
A55R1	0757-0276	7	1	RESISTOR 61.9 1% .125W F TC=0+-100	24546	C4-1/8-T0-6192-F
A55R2	0699-0961	3	1	RESISTOR 720 .1% .1W F TC=0+4	28480	0699-0961
A55R3	0699-0059	0	1	RESISTOR 5K .1% .1W F TC=0+-5	28480	0699-0059
A55R4	2100-3056	8	1	RESISTOR-TMR 5K 10% C SIDE-ADJ 17-TRN	02111	43P502
A55R5	0757-0440	7	2	RESISTOR 7.5K 1% .125W F TC=0+-100	24546	C4-1/8-T0-7501-F
A55R6	0757-0440	7	7	RESISTOR 7.5K 1% .125W F TC=0+-100	24546	C4-1/8-T0-7501-F
A55R7	0757-0467	8	1	RESISTOR 121K 1% .125W F TC=0+-100	24546	C4-1/8-T0-1213-F
A55R8	0757-0438	3	2	RESISTOR 5.11K 1% .125W F TC=0+-100	24546	C4-1/8-T0-5111-F
A55R9	0757-0438	3	3	RESISTOR 5.11K 1% .125W F TC=0+-100	24546	C4-1/8-T0-5111-F
A55R10	0757-0465	6	2	RESISTOR 100K 1% .125W F TC=0+-100	24546	C4-1/8-T0-1003-F
A55R11	0698-0083	8	1	RESISTOR 1.96K 1% .125W F TC=0+-100	24546	C4-1/8-T0-1961-F
A55R12				NOT ASSIGNED		
A55R13	0698-3157	3	1	RESISTOR 19.6K 1% .125W F TC=0+-100	24546	C4-1/8-T0-1962-F
A55R14	0757-0442	9	6	RESISTOR 10K 1% .125W F TC=0+-100	24546	C4-1/8-T0-1002-F
A55R15	0698-3440	7	1	RESISTOR 196 1% .125W F TC=0+-100	24546	C4-1/8-T0-196R-F
A55R16-19				NOT ASSIGNED		
A55R20	0757-0294	9	1	RESISTOR 17.8 1% .125W F TC=0+-100	19701	MF4C1/8-T0-17R8-F
A55R21	0757-0458	7	1	RESISTOR 51.1K 1% .125W F TC=0+-100	24546	C4-1/8-T0-5112-F
A55R22	0757-0465	6	2	RESISTOR 100K 1% .125W F TC=0+-100	24546	C4-1/8-T0-1003-F
A55R23	0757-0401	0	2	RESISTOR 100 1% .125W F TC=0+-100	24546	C4-1/8-T0-101-F
A55R24	0757-0421	4	1	RESISTOR 825 1% .125W F TC=0+-100	24546	C4-1/8-T0-825R-F
A55R25, 26				NOT ASSIGNED		
A55R27	0757-0346	2	6	RESISTOR 10 1% .125W F TC=0+-100	24546	C4-1/8-T0-10R0-F
A55R28	0757-0346	2	2	RESISTOR 10 1% .125W F TC=0+-100	24546	C4-1/8-T0-10R0-F
A55R29	0698-3154	0	1	RESISTOR 4.22K 1% .125W F TC=0+-100	24546	C4-1/8-T0-4221-F

See instruction to this section for ordering information.

*Indicates factory selected value.

Table 6-3. Replaceable Parts

Reference Designation	HP Part Number	C D	Qty	Description	Mfr Code	Mfr Part Number
A55R30, 31				NOT ASSIGNED		
A55R32	0757-0278	9	1	RESISTOR 1.78K 1% .125W F TC=0+-100	24546	C4-1/B-T0-1781-F
A55R33	0757-0443	0	3	RESISTOR 11K 1% .125W F TC=0+-100	24546	C4-1/B-T0-1102-F
A55R34-37				NOT ASSIGNED		
A55R38	0757-0441	8	1	RESISTOR 8.25K 1% .125W F TC=0+-100	24546	C4-1/B-T0-8251-F
A55R39				NOT ASSIGNED		
A55R40	0757-0442	9		RESISTOR 10K 1% .125W F TC=0+-100	24546	C4-1/B-T0-1002-F
A55R41	0757-0442	9		RESISTOR 10K 1% .125W F TC=0+-100	24546	C4-1/B-T0-1002-F
A55R42	0757-0346	2		RESISTOR 10 1% .125W F TC=0+-100	24546	C4-1/B-T0-10R0-F
A55R43	0757-0346	2		RESISTOR 10 1% .125W F TC=0+-100	24546	C4-1/B-T0-10R0-F
A55R44	0757-0346	2		RESISTOR 10 1% .125W F TC=0+-100	24546	C4-1/B-T0-10R0-F
A55R45	0757-0346	2		RESISTOR 10 1% .125W F TC=0+-100	24546	C4-1/B-T0-10R0-F
A55R46	0757-0428	1	1	RESISTOR 1.62K 1% .125W F TC=0+-100	24546	C4-1/B-T0-1621-F
A55R47	2100-3103	6	1	RESISTOR-TRMR 10K 10% C SIDE-ADJ 17-TRN	02111	43P103
A55R48	0757-0442	9		RESISTOR 10K 1% .125W F TC=0+-100	24546	C4-1/B-T0-1002-F
A55R49	0757-0442	9		RESISTOR 10K 1% .125W F TC=0+-100	24546	C4-1/B-T0-1002-F
A55R50	0757-0279	0	1	RESISTOR 3.16K 1% .125W F TC=0+-100	24546	C4-1/B-T0-3161-F
A55R51	0757-0443	0		RESISTOR 11K 1% .125W F TC=0+-100	24546	C4-1/B-T0-1102-F
A55R52	0757-0443	0		RESISTOR 11K 1% .125W F TC=0+-100	24546	C4-1/B-T0-1102-F
A55R53	0757-0442	9		RESISTOR 10K 1% .125W F TC=0+-100	24546	C4-1/B-T0-1002-F
A55R54				NOT ASSIGNED		
A55R55	0757-0199	3	1	RESISTOR 21.5K 1% .125W F TC=0+-100	24546	C4-1/B-T0-2152-F
A55R56-59				NOT ASSIGNED		
A55R60	0757-0814	9	1	RESISTOR 511 1% .5W F TC=0+-100	28480	0757-0814
A55R61	0698-3442	9	1	RESISTOR 237 1% .125W F TC=0+-100	24546	C4-1/B-T0-237R-F
A55R62	0698-3153	9	1	RESISTOR 3.83K 1% .125W F TC=0+-100	24546	C4-1/B-T0-3831-F
A55R63	0757-0401	0		RESISTOR 100 1% .125W F TC=0+-100	24546	C4-1/B-T0-101-F
A55TP1	0360-0535	0	5	TERMINAL TEST POINT PCB	00000	ORDER BY DESCRIPTION
A55TP2	0360-0535	0		TERMINAL TEST POINT PCB	00000	ORDER BY DESCRIPTION
A55TP3	0360-0535	0		TERMINAL TEST POINT PCB	00000	ORDER BY DESCRIPTION
A55TP4	0360-0535	0		TERMINAL TEST POINT PCB	00000	ORDER BY DESCRIPTION
A55TP5	0360-0535	0		TERMINAL TEST POINT PCB	00000	ORDER BY DESCRIPTION
A55U1	1826-0783	9	2	IC OP AMP LOW-NOISE 8-DIP-C PKG	52063	XR5534ACN
A55U2	1826-0783	9		IC OP AMP LOW-NOISE 8-DIP-C PKG	52063	XR5534ACN
A55U3	1826-0226	5	1	IC V RGLTR TO-39	07263	78M12HC
A55U4	1826-0558	6	1	IC 337 V RGLTR TO-39	27014	LM337H
A55U5	1820-1197	9	1	IC GATE TTL LS NAND QUAD 2-INP	01295	SN74LS00N
A55VR1	1902-0197	1	1	DIODE-ZNR 82V 5% PD=1W IR=5UA	28480	1902-0197
A55VR2	1902-0625	0	1	DIODE-ZNR 1N829 6.2V 5% DO-7 PD=.25W	04713	1N829

See Introduction to this section for ordering information.

*Indicates factory selected value.

Table 6-3. Model 8340A Replaceable Parts

Reference Designation	HP Part Number	C D	Qty	Description	Mfr Code	Mfr Part Number
A56	08340-60029	2	1	-15V REGULATOR	28480	08340-60029
A56C1	0180-2505	6	1	CAPACITOR-FXD 1UF+10% 75VDC TA	56289	150D105X9075B2
A56C2	0180-2129	0	1	CAPACITOR-FXD 10UF+10% 50VDC TA	56289	150D106X9050R2
A56C3	0180-0291	3	1	CAPACITOR-FXD 1UF+10% 35VDC TA	56289	150D105X9035A2
A56CR1	1901-0033	2	1	DIODE-GEN PRP 180V 200MA DO-7	28480	1901-0033
A56CR2	1901-0662	3	2	DIODE-PWR RECT 100V 6A	04713	MR751
A56CR3	1901-0662	3	3	DIODE-PWR RECT 100V 6A	04713	MR751
A56DS1	1990-0487	7	1	LED-LAMP LUM-INT=1MCD IF=20MA-MAX BVR=5V	28480	5082-4584
A56E1	1251-2313	6	2	CONNECTOR-SGL CONT SKT .04-IN-BSC-SZ RND	28480	1251-2313
A56E2	1251-2313	6	6	CONNECTOR-SGL CONT SKT .04-IN-BSC-SZ RND	28480	1251-2313
A56F1	2110-0047	2	1	FUSE 1A 125V .25X.27	71400	GMW-1
A56MP1	5040-6849	8	1	EXTRACTOR, P.C. BOARD	28480	5040-6849
A56MP2	5000-9043	6	1	PIN:P.C. BOARD EXTRACTOR	28480	5000-9043
A56MP3	08340-00030	9	1	HEAT SINK	28480	08340-00030
A56MP4	0590-0526	6	1	THREADED INSERT-NUT 4-40 .065-IN-LG SST	28480	0590-0526
A56MP5	2200-0105	4	1	SCREW-MACH 4-40 .312-IN-LG PAN-HD-POZI	00000	ORDER BY DESCRIPTION
A56Q1	1884-0244	9	1	THYRISTOR-SCR VRRM=400	3L585	S2600D
A56Q2	1855-0414	4	1	TRANSISTOR J-FET 2N4393 N-CHAN D-MODE	04713	2N4393
A56R1	0811-1084	3	2	RESISTOR 22 5% 3W PW TC=0+30	28480	0811-1084
A56R2	0698-3444	1	1	RESISTOR 316 1% .125W F TC=0+100	24546	C4-1/8-T0-316R-F
A56R3	0757-0346	2	1	RESISTOR 10 1% .125W F TC=0+100	24546	C4-1/8-T0-10R0-F
A56R4	0698-3132	4	1	RESISTOR 261 1% .125W F TC=0+100	24546	C4-1/8-T0-2610-F
A56R5	0757-0280	3	1	RESISTOR 1K 1% .125W F TC=0+100	24546	C4-1/8-T0-1001-F
A56R6	0811-1084	3	1	RESISTOR 22 5% 3W PW TC=0+30	28480	0811-1084
A56R7	0757-0403	2	1	RESISTOR 121 1% .125W F TC=0+100	24546	C4-1/8-T0-121R-F
A56TP1	0360-0535	0	2	TERMINAL TEST POINT PCB	00000	ORDER BY DESCRIPTION
A56TP2	0360-0535	0	0	TERMINAL TEST POINT PCB	00000	ORDER BY DESCRIPTION
A56U1	1826-0523	5	1	IC 337 V RGLTR TO-3	27014	LM337K
A56VR1	1902-3224	1	1	DIODE-ZNR 17.8V 5% DO-35 PD=.4W	28480	1902-3224
A56VR2	1902-3182	0	1	DIODE-ZNR 12.1V 5% DO-35 PD=.4W	28480	1902-3182
A56VR3	1902-0025	4	1	DIODE-ZNR 10V 5% DO-35 PD=.4W TC=+.06%	28480	1902-0025
A56VR4	1902-3197	7	1	DIODE-ZNR 13.7V 2% DO-35 PD=.4W	28480	1902-3197

See introduction to this section for ordering information
 *Indicates factory selected value

Table 6-3. Model 8340A Replaceable Parts

Reference Designation	HP Part Number	C D	Qty	Description	Mfr Code	Mfr Part Number
A57	08340-60014	5	1	MARKER/BANDCROSS	28480	08340-60014
A57C1	0180-0291	3	2	CAPACITOR-FXD 1UF+10% 35VDC TA	56289	150D105X9035A2
A57C2	0180-0291	3		CAPACITOR-FXD 1UF+10% 35VDC TA	56289	150D105X9035A2
A57C3	0180-0197	8	1	CAPACITOR-FXD 2.2UF+10% 20VDC TA	56289	150D225X9020A2
A57C4	0160-4832	4	18	CAPACITOR-FXD .01UF +10% 100VDC CER	28480	0160-4832
A57C5	0160-4832	4		CAPACITOR-FXD .01UF +10% 100VDC CER	28480	0160-4832
A57C6	0160-4832	4		CAPACITOR-FXD .01UF +10% 100VDC CER	28480	0160-4832
A57C7	0160-4832	4		CAPACITOR-FXD .01UF +10% 100VDC CER	28480	0160-4832
A57C8	0160-4832	4		CAPACITOR-FXD .01UF +10% 100VDC CER	28480	0160-4832
A57C9	0160-4832	4		CAPACITOR-FXD .01UF +10% 100VDC CER	28480	0160-4832
A57C10	0160-4832	4		CAPACITOR-FXD .01UF +10% 100VDC CER	28480	0160-4832
A57C11	0160-4832	4		CAPACITOR-FXD .01UF +10% 100VDC CER	28480	0160-4832
A57C12	0160-4832	4		CAPACITOR-FXD .01UF +10% 100VDC CER	28480	0160-4832
A57C13	0160-4832	4		CAPACITOR-FXD .01UF +10% 100VDC CER	28480	0160-4832
A57C14	0160-4832	4		CAPACITOR-FXD .01UF +10% 100VDC CER	28480	0160-4832
A57C15	0160-4832	4		CAPACITOR-FXD .01UF +10% 100VDC CER	28480	0160-4832
A57C16	0160-4832	4		CAPACITOR-FXD .01UF +10% 100VDC CER	28480	0160-4832
A57C17	0160-4823	3	1	CAPACITOR-FXD 820PF +5% 100VDC CER	28480	0160-4823
A57C18	0160-4801	7	1	CAPACITOR-FXD 100PF +5% 100VDC CER	28480	0160-4801
A57C19	0160-4832	4		CAPACITOR-FXD .01UF +10% 100VDC CER	28480	0160-4832
A57C20	0160-4807	3	3	CAPACITOR-FXD 33PF +5% 100VDC CER 0+30	28480	0160-4807
A57C21	0160-4819	7	2	CAPACITOR-FXD 2200PF +5% 100VDC CER	28480	0160-4819
A57C22	0160-4819	7		CAPACITOR-FXD 2200PF +5% 100VDC CER	28480	0160-4819
A57C23	0160-4807	3		CAPACITOR-FXD 33PF +5% 100VDC CER 0+30	28480	0160-4807
A57C24	0160-4807	3		CAPACITOR-FXD 33PF +5% 100VDC CER 0+30	28480	0160-4807
A57C25	0160-4832	4		CAPACITOR-FXD .01UF +10% 100VDC CER	28480	0160-4832
A57C26	0160-4832	4		CAPACITOR-FXD .01UF +10% 100VDC CER	28480	0160-4832
A57C27	0160-4832	4		CAPACITOR-FXD .01UF +10% 100VDC CER	28480	0160-4832
A57C28	0160-4832	4		CAPACITOR-FXD .01UF +10% 100VDC CER	28480	0160-4832
A57CR1	1901-0535	9	4	DIODE-SM SIG SCHOTTKY	28480	1901-0535
A57CR2	1901-0535	9		DIODE-SM SIG SCHOTTKY	28480	1901-0535
A57CR3	1901-0535	9		DIODE-SM SIG SCHOTTKY	28480	1901-0535
A57CR4	1901-0535	9		DIODE-SM SIG SCHOTTKY	28480	1901-0535
A57CR5	1901-0033	2	6	DIODE-GEN PRP 180V 200MA DO-7	28480	1901-0033
A57CR6	1901-0033	2		DIODE-GEN PRP 180V 200MA DO-7	28480	1901-0033
A57CR7	1901-0033	2		DIODE-GEN PRP 180V 200MA DO-7	28480	1901-0033
A57CR8	1901-0033	2		DIODE-GEN PRP 180V 200MA DO-7	28480	1901-0033
A57CR9	1901-0033	2		DIODE-GEN PRP 180V 200MA DO-7	28480	1901-0033
A57CR10	1901-0033	2		DIODE-GEN PRP 180V 200MA DO-7	28480	1901-0033
A57L1	9100-3562	8	2	INDUCTOR RF-CH-MLD 4.7UH 5% .166DX.385LG	28480	9100-3562
A57L2	9100-3562	8		INDUCTOR RF-CH-MLD 4.7UH 5% .166DX.385LG	28480	9100-3562
A57L3	9100-1788	6	1	CHOKE-WIDE BAND ZMAX=680 OHM@ 180 MHZ	02114	VK200 20/48
A57MP1, 2	1480-0073	6	2	PIN-ROLL .062-IN-DIA .25-IN-LG BE-CU	28480	1480-0073
A57MP3	4040-0755	2	1	EXTR-PC BD VIO POLYLC .062-BD-THKNS	28480	4040-0755
A57P1	1251-7469	3	1	CONN - POST TYPE	28480	1251-7469
A57Q1	1854-0404	0	1	TRANSISTOR NPN SI TO-18 PD=360MW	28480	1854-0404
A57Q2	1854-0477	7	1	TRANSISTOR NPN 2N2222A SI TO-18 PD=500MW	04713	2N2222A
A57Q3	1854-0361	8	1	TRANSISTOR NPN 2N4239 SI TO-5 PD=6W	04713	2N4239
A57R1	0757-0280	3	8	RESISTOR 1K 1% .125W F TC=0+100	24546	C4-1/8-T0-1001-F
A57R2	0757-0280	3		RESISTOR 1K 1% .125W F TC=0+100	24546	C4-1/8-T0-1001-F
A57R3	0757-0280	3		RESISTOR 1K 1% .125W F TC=0+100	24546	C4-1/8-T0-1001-F
A57R4	0757-0442	9	4	RESISTOR 10K 1% .125W F TC=0+100	24546	C4-1/8-T0-1002-F
A57R5	0698-3441	8	1	RESISTOR 215 1% .125W F TC=0+100	24546	C4-1/8-T0-215R-F
A57R6	0757-0438	3	2	RESISTOR 5.11K 1% .125W F TC=0+100	24546	C4-1/8-T0-5111-F
A57R7	0757-0402	1	1	RESISTOR 110 1% .125W F TC=0+100 (Recommended Replacement)	24546	C4-1/8-T0-110R-F
A57R8				NOT ASSIGNED		
A57R9	0757-0403	2	1	RESISTOR 121 1% .125W F TC=0+100	24546	C4-1/8-T0-121R-F
A57R10	0690-1021	0	2	RESISTOR 1K 10% 1W CC TC=0+647	01121	GB1021
A57R11	0690-1021	0		RESISTOR 1K 10% 1W CC TC=0+647	01121	GB1021
A57R12	0757-0401	0	2	RESISTOR 100 1% .125W F TC=0+100	24546	C4-1/8-T0-101-F
A57R13	0757-0401	0		RESISTOR 100 1% .125W F TC=0+100	24546	C4-1/8-T0-101-F
A57R14-16				NOT ASSIGNED		
A57R17	0698-0083	8	2	RESISTOR 1.96K 1% .125W F TC=0+100	24546	C4-1/8-T0-1961-F
A57R18	0757-0394	0	1	RESISTOR 51.1 1% .125W F TC=0+100	24546	C4-1/8-T0-51R1-F
A57R19	0757-0288	1	3	RESISTOR 9.09K 1% .125W F TC=0+100	19701	MF4C1/8-T0-9091-F
A57R20	0757-0443	0	3	RESISTOR 11K 1% .125W F TC=0+100	24546	C4-1/8-T0-1102-F
A57R21	0757-0288	1		RESISTOR 9.09K 1% .125W F TC=0+100	19701	MF4C1/8-T0-9091-F
A57R22	0757-0288	1		RESISTOR 9.09K 1% .125W F TC=0+100	19701	MF4C1/8-T0-9091-F
A57R23	0757-0443	0		RESISTOR 11K 1% .125W F TC=0+100	24546	C4-1/8-T0-1102-F
A57R24	0757-0442	9		RESISTOR 10K 1% .125W F TC=0+100	24546	C4-1/8-T0-1002-F

See introduction to this section for ordering information
 *Indicates factory selected value

Table 6-3. Model 8340A Replaceable Parts

Reference Designation	HP Part Number	C D	Qty	Description	Mfr Code	Mfr Part Number
A57R25	0757-0442	9		RESISTOR 10K 1% .125W F TC=0+100	24546	C4-1/8-T0-1002-F
A57R26	0757-0465	6	2	RESISTOR 100K 1% .125W F TC=0+100	24546	C4-1/8-T0-1003-F
A57R27	0757-0421	4	1	RESISTOR 825 1% .125W F TC=0+100	24546	C4-1/8-T0-825R-F
A57R28	0757-0465	6		RESISTOR 100K 1% .125W F TC=0+100	24546	C4-1/8-T0-1003-F
A57R29	0757-0438	3		RESISTOR 5.11K 1% .125W F TC=0+100	24546	C4-1/8-T0-5111-F
A57R30	0757-0443	0		RESISTOR 11K 1% .125W F TC=0+100	24546	C4-1/8-T0-1102-F
A57R31	0698-0083	8		RESISTOR 1.96K 1% .125W F TC=0+100	24546	C4-1/8-T0-1961-F
A57R32	2100-3757	6	1	RESISTOR-TRMR 100 10% C SIDE-ADJ 17-TRN	28480	2100-3757
A57R33	2100-3757	6	1	RESISTOR-TRMR 100 10% C SIDE-ADJ 17-TRN (Recommended Replacement)	28480	2100-3757
A57R34	0757-0280	3		RESISTOR 1K 1% .125W F TC=0+100	24546	C4-1/8-T0-1001-F
A57R35	0757-0280	3		RESISTOR 1K 1% .125W F TC=0+100	24546	C4-1/8-T0-1001-F
A57R36	0757-0280	3		RESISTOR 1K 1% .125W F TC=0+100	24546	C4-1/8-T0-1001-F
A57R37	0757-0280	3		RESISTOR 1K 1% .125W F TC=0+100	24546	C4-1/8-T0-1001-F
A57R38	0757-0280	3		RESISTOR 1K 1% .125W F TC=0+100	24546	C4-1/8-T0-1001-F
A57R39	0757-0346	2	2	RESISTOR 10 1% .125W F TC=0+100	24546	C4-1/8-T0-10R0-F
A57R40	0757-0346	2		RESISTOR 10 1% .125W F TC=0+100	24546	C4-1/8-T0-10R0-F
A57R41	0757-0442	9		RESISTOR 10K 1% .125W F TC=0+100	24546	C4-1/8-T0-1002-F
A57TP1	0360-2050	8	5	TEST POINT	28480	0360-2050
A57TP2	0360-2050	8		TEST POINT	28480	0360-2050
A57TP3	0360-2050	8		TEST POINT	28480	0360-2050
A57TP4	0360-2050	8		TEST POINT	28480	0360-2050
A57TP5	0360-2050	8		TEST POINT	28480	0360-2050
A57U1	1820-1194	6	2	IC CNTR TTL LS BIN UP/DOWN SYNCHRO	01295	SN74LS193N
A57U2	1818-0135	8	2	IC NMOS 1024 (1K) STAT RAM 360-NS 3-S	04713	MCM68A10L
A57U3	1820-1984	2	2	IC CONV 10-B-D/A 16-DIP-C PKG	24355	AD561KD
A57U4	1820-1984	2		IC CONV 10-B-D/A 16-DIP-C PKG	24355	AD561KD
A57U5	1820-1437	0	1	IC MV TTL LS MONOSTBL DUAL	01295	SN74LS221N
A57U6	1826-0098	9	1	IC COMPARATOR PRCN TO-99 PKG	27014	LM211H
A57U7	1826-0471	2	3	IC OP AMP LOW-DRIFT TO-99 PKG	28480	1826-0471
A57U8	1820-2075	4	2	IC MISC TTL LS	01295	SN74LS245N
A57U9	1820-1196	8	3	IC FF TTL LS D-TYPE POS-EDGE-TRIG COM	01295	SN74LS174N
A57U10	1820-1194	6		IC CNTR TTL LS BIN UP/DOWN SYNCHRO	01295	SN74LS193N
A57U11	1820-1112	8	2	IC FF TTL LS D-TYPE POS-EDGE-TRIG	01295	SN74LS74AN
A57U12	1820-1425	6	1	IC SCHMITT-TRIG TTL LS NAND QUAD 2-INP	01295	SN74LS132N
A57U13	1820-1272	1	1	IC BFR TTL LS NOR QUAD 2-INP	01295	SN74LS33N
A57U14	1826-0081	0	2	IC OP AMP WB TO-99 PKG	27014	LM318H
A57U15	1818-0135	8		IC NMOS 1024 (1K) STAT RAM 360-NS 3-S	04713	MCM68A10L
A57U16	1820-2075	4		IC MISC TTL LS	01295	SN74LS245N
A57U17	1820-1196	8		IC FF TTL LS D-TYPE POS-EDGE-TRIG COM	01295	SN74LS174N
A57U18	1820-1196	8		IC FF TTL LS D-TYPE POS-EDGE-TRIG COM	01295	SN74LS174N
A57U19	1820-1298	1	1	IC MUXR/DATA-SEL TTL LS 8-TO-1-LINE	01295	SN74LS251N
A57U20	1820-1144	6	2	IC GATE TTL LS NOR QUAD 2-INP	01295	SN74LS02N
A57U21	1820-1144	6		IC GATE TTL LS NOR QUAD 2-INP	01295	SN74LS02N
A57U22	1826-0081	0		IC OP AMP WB TO-99 PKG	27014	LM318H
A57U23	1820-1730	6	1	IC FF TTL LS D-TYPE POS-EDGE-TRIG COM	01295	SN74LS273N
A57U24	1820-1491	6	1	IC BFR TTL LS NON-INV HEX 1-INP	01295	SN74LS367AN
A57U25	1820-1216	3	2	IC DCDR TTL LS 3-TO-8-LINE 3-INP	01295	SN74LS138N
A57U26	1820-1112	8		IC FF TTL LS D-TYPE POS-EDGE-TRIG	01295	SN74LS74AN
A57U27	1826-0471	2		IC OP AMP LOW-DRIFT TO-99 PKG	28480	1826-0471
A57U28	1820-1216	3		IC DCDR TTL LS 3-TO-8-LINE 3-INP	01295	SN74LS138N
A57U29	1820-1201	6	1	IC GATE TTL LS AND QUAD 2-INP	01295	SN74LS08N
A57U30	1826-0471	2		IC OP AMP LOW-DRIFT TO-99 PKG	28480	1826-0471
A57U31	1810-0583	4	1	NETWORK-RES 16-DIP10.0K OHM X 8	28480	1810-0583
A57VR1	1902-3104	6	3	DIODE-ZNR 5.62V 5% DO-35 PD=.4W	28480	1902-3104
A57VR2	1902-3104	6		DIODE-ZNR 5.62V 5% DO-35 PD=.4W	28480	1902-3104
A57VR3	1902-3104	6		DIODE-ZNR 5.62V 5% DO-35 PD=.4W	28480	1902-3104
A57VR4	1902-0579	3	2	DIODE-ZNR 5.1V 5% PD=1W IR=100A	28480	1902-0579
A57VR5	1902-3357	1	1	DIODE-ZNR 56.2V 5% DO-7 PD=.4W TC=+.081%	28480	1902-3357
A57VR6	1902-0579	3		DIODE-ZNR 5.1V 5% PD=1W IR=100A	28480	1902-0579

See introduction to this section for ordering information
 *Indicates factory selected value

Table 6-3. Replaceable Parts

Reference Designation	HP Part Number	C D	Qty	Description	Mfr Code	Mfr Part Number
A58	08340-60154	4	1	SWEEP GENERATOR	28480	08340-60154
A58C1	0180-0291	1	1	CAPACITOR-FXD .1UF +10% 35VDC TA	28480	0180-0291
A58C2	0160-4841	5	38	CAPACITOR-FXD .1UF +80-20% 50VDC CER	28480	0160-4841
A58C3				NOT ASSIGNED		
A58C4	0160-4841	5		CAPACITOR-FXD .1UF +80-20% 50VDC CER	28480	0160-4841
A58C5	0160-4841	5		CAPACITOR-FXD .1UF +80-20% 50VDC CER	28480	0160-4841
A58C6, 7				NOT ASSIGNED		
A58C8	0160-4841	5		CAPACITOR-FXD .1UF +80-20% 50VDC CER	28480	0160-4841
A58C9	0160-4832	4	8	CAPACITOR-FXD .01UF +10% 100VDC CER	28480	0160-4832
A58C10	0160-4832	4		CAPACITOR-FXD .01UF +10% 100VDC CER	28480	0160-4832
A58C11	0160-4841	5		CAPACITOR-FXD .1UF +80-20% 50VDC CER	28480	0160-4841
A58C12	0160-4841	5		CAPACITOR-FXD .1UF +80-20% 50VDC CER	28480	0160-4841
A58C13	0160-4841	5		CAPACITOR-FXD .1UF +80-20% 50VDC CER	28480	0160-4841
A58C14	0160-4841	5		CAPACITOR-FXD .1UF +80-20% 50VDC CER	28480	0160-4841
A58C15	0160-4841	5		CAPACITOR-FXD .1UF +80-20% 50VDC CER	28480	0160-4841
A58C16	0160-4841	5		CAPACITOR-FXD .1UF +80-20% 50VDC CER	28480	0160-4841
A58C17	0160-4841	5		CAPACITOR-FXD .1UF +80-20% 50VDC CER	28480	0160-4841
A58C18	0160-4841	5		CAPACITOR-FXD .1UF +80-20% 50VDC CER	28480	0160-4841
A58C19	0160-4832	4		CAPACITOR-FXD .01UF +10% 100VDC CER	28480	0160-4832
A58C20	0160-4841	5		CAPACITOR-FXD .1UF +80-20% 50VDC CER	28480	0160-4841
A58C21	0160-4841	5		CAPACITOR-FXD .1UF +80-20% 50VDC CER	28480	0160-4841
A58C22	0160-4810	8	1	CAPACITOR-FXD 330PF +5% 100VDC CER	28480	0160-4810
A58C23	0160-4841	5		CAPACITOR-FXD .1UF +80-20% 50VDC CER	28480	0160-4841
A58C24	0160-4841	5		CAPACITOR-FXD .1UF +80-20% 50VDC CER	28480	0160-4841
A58C25	0160-4841	5		CAPACITOR-FXD .1UF +80-20% 50VDC CER	28480	0160-4841
A58C26	0160-4825	5	1	CAPACITOR-FXD 560PF +5% 100VDC CER	28480	0160-4825
A58C27				NOT ASSIGNED		
A58C28	0160-4841	5		CAPACITOR-FXD .1UF +80-20% 50VDC CER	28480	0160-4841
A58C29	0160-4841	5		CAPACITOR-FXD .1UF +80-20% 50VDC CER	28480	0160-4841
A58C30	0160-5662	0	1	CAPACITOR-FXD 5UF +10% 50VDC NET-POLYLC	28480	0160-5662
A58C31	0160-4265	7	1	CAPACITOR-FXD .47UF +20% 50VDC	84411	HEW 386
A58C32	0160-4832	4		CAPACITOR-FXD .01UF +10% 100VDC CER	28480	0160-4832
A58C33	0160-4841	5		CAPACITOR-FXD .1UF +80-20% 50VDC CER	28480	0160-4841
A58C34	0160-4841	5		CAPACITOR-FXD .1UF +80-20% 50VDC CER	28480	0160-4841
A58C35	0160-4841	5		CAPACITOR-FXD .1UF +80-20% 50VDC CER	28480	0160-4841
A58C36	0160-4841	5		CAPACITOR-FXD .1UF +80-20% 50VDC CER	28480	0160-4841
A58C37	0160-4841	5		CAPACITOR-FXD .1UF +80-20% 50VDC CER	28480	0160-4841
A58C38	0160-4841	5		CAPACITOR-FXD .1UF +80-20% 50VDC CER	28480	0160-4841
A58C39	0160-4807	3	1	CAPACITOR-FXD 33PF +5% 100VDC CER 0+30	28480	0160-4807
A58C40	0160-4841	5		CAPACITOR-FXD .1UF +80-20% 50VDC CER	28480	0160-4841
A58C41	0160-4841	5		CAPACITOR-FXD .1UF +80-20% 50VDC CER	28480	0160-4841
A58C42	0160-4841	5		CAPACITOR-FXD .1UF +80-20% 50VDC CER	28480	0160-4841
A58C43	0160-4832	4		CAPACITOR-FXD .01UF +10% 100VDC CER	28480	0160-4832
A58C44	0160-4832	4		CAPACITOR-FXD .01UF +10% 100VDC CER	28480	0160-4832
A58C45	0160-4832	4		CAPACITOR-FXD .01UF +10% 100VDC CER	28480	0160-4832
A58C46	0160-4841	5		CAPACITOR-FXD .1UF +80-20% 50VDC CER	28480	0160-4841
A58C47	0160-4841	5		CAPACITOR-FXD .1UF +80-20% 50VDC CER	28480	0160-4841
A58C48	0180-1731	8	1	CAPACITOR-FXD 4.7UF +10% 50VDC TA	28480	0180-1731
A58C49	0180-0374	3	1	CAPACITOR-FXD 10UF +10% 20VDC TA	56289	1500106X9020B2
A58C50	0160-4841	5		CAPACITOR-FXD .1UF +80-20% 50VDC CER	28480	0160-4841
A58C51	0180-0116	1	3	CAPACITOR-FXD 6.8UF +10% 35VDC TA	28480	0180-0116
A58C52	0180-0116	1		CAPACITOR-FXD 6.8UF +10% 35VDC TA	28480	0180-0116
A58C53	0160-4841	5		CAPACITOR-FXD .1UF +80-20% 50VDC CER	28480	0160-4841
A58C54	0160-4841	5		CAPACITOR-FXD .1UF +80-20% 50VDC CER	28480	0160-4841
A58C55	0160-4841	5		CAPACITOR-FXD .1UF +80-20% 50VDC CER	28480	0160-4841
A58C56	0160-4841	5		CAPACITOR-FXD .1UF +80-20% 50VDC CER	28480	0160-4841
A58C57	0160-4832	4		CAPACITOR-FXD .01UF +10% 100VDC CER	28480	0160-4832
A58C58	0180-0116	1		CAPACITOR-FXD 6.8UF +10% 35VDC TA	28480	0180-0116
A58C59	0160-4841	5		CAPACITOR-FXD .1UF +80-20% 50VDC CER	28480	0160-4841
A58C60	0160-4841	5		CAPACITOR-FXD .1UF +80-20% 50VDC CER	28480	0160-4841
A58C61	0160-4841	5		CAPACITOR-FXD .1UF +80-20% 50VDC CER	28480	0160-4841
A58CR1	1901-1098	1	2	DIODE-SWITCHING 1N4150 50V 200MA 4NS	9N171	1N4150
A58CR2	1901-0586	0	9	DIODE-GEN PRP 30V 25MA TO-72	28480	1901-0586
A58CR3	1901-0586	0		DIODE-GEN PRP 30V 25MA TO-72	28480	1901-0586
A58CR4	1901-1098	1		DIODE-SWITCHING 1N4150 50V 200MA 4NS	9N171	1N4150
A58CR5	1901-0518	8	2	DIODE-SM SIG SCHOTTKY	28480	1901-0518
A58CR6	1901-0518	8		DIODE-SM SIG SCHOTTKY	28480	1901-0518
A58CR7	1901-0033	2	2	DIODE-GEN PRP 180V 200MA DO-7	28480	1901-0033
A58CR8				NOT ASSIGNED		
A58CR9	1901-0033	2		DIODE-GEN PRP 180V 200MA DO-7	28480	1901-0033
A58L1	9140-0210	1	4	INDUCTOR RF-CH-MLD 100UH 5% .166DX.385LG	28480	9140-0210
A58L2	9100-0539	3	1	INDUCTOR RF-CH-MLD 10UH 5% .156DX.375LG	28480	9100-0539
A58L3	9140-0210	1		INDUCTOR RF-CH-MLD 100UH 5% .166DX.385LG	28480	9140-0210

See introduction to this section for ordering information
 *Indicates factory selected value

SERIAL PREFIX: 2406A

Table 6-3. Replaceable Parts

Reference Designation	HP Part Number	C D	Qty	Description	Mfr Code	Mfr Part Number
A58L4	9140-0210	1		INDUCTOR RF-CH-MLD 100UH 5% .166DX.385LG	28480	9140-0210
A58L5	9140-0210	1		INDUCTOR RF-CH-MLD 100UH 5% .166DX.385LG	28480	9140-0210
A58MP1	4040-0753	0	1	EXTR-PC BD GRN POLYC .062-BD-THKNS	28480	4040-0753
A58MP2	4040-0747	2	1	EXTR-PC BD GRA POLYC .062-BD-THKNS	28480	4040-0747
A58MP3	1480-0073	6	2	PIN-ROLL .062-IN-DIA .25-IN-LG BE-CU	28480	1480-0073
A58MP4,5				NOT ASSIGNED		
A58MP6	1205-0011	0	1	HEAT SINK TO-5/TO-39-CS	28480	1205-0011
A58MP7	1200-0172	4	2	INSULATOR-XSTR DAP-GL	28480	1200-0172
A58MP8	0380-1221	5	1	STANDOFF-RUT-ON .25-IN-LG 2-56 THD	28480	0380-1221
A58MP9	08340-00068	3	1	DAC SHIELD	28480	08340-00068
A58MP10	0520-0126	5	1	SCREW-MACH 2-56 .125-IN-LG 100DEG	28480	0520-0126
A58MP11	2190-0112	0	1	WASHER LK .088-IN-DIA	28480	2190-0112
A58P1	1251-7469	3	1	CONN - POST TYPE	28480	1251-7469
A58Q1	1855-0420	2	10	TRANSISTOR J-FET 2N4391 N-CHAN D-MODE	01295	2N4391
A58Q2	1855-0420	2		TRANSISTOR J-FET 2N4391 N-CHAN D-MODE	01295	2N4391
A58Q3	1855-0420	2		TRANSISTOR J-FET 2N4391 N-CHAN D-MODE	01295	2N4391
A58Q4	1855-0420	2		TRANSISTOR J-FET 2N4391 N-CHAN D-MODE	01295	2N4391
A58Q5	1855-0278	8	1	TRANSISTOR J-FET 2N5116 P-CHAN D-MODE	17856	2N5116
A58Q6	1855-0386	2		TRANSISTOR J-FET 2N4392 N-CHAN D-MODE	04713	2N4392
A58Q7	1855-0420	2		TRANSISTOR J-FET 2N4391 N-CHAN D-MODE	01295	2N4391
A58Q8	1855-0420	2		TRANSISTOR J-FET 2N4391 N-CHAN D-MODE	01295	2N4391
A58Q9	1855-0420	2		TRANSISTOR J-FET 2N4391 N-CHAN D-MODE	01295	2N4391
A58Q10	1855-0420	2		TRANSISTOR J-FET 2N4391 N-CHAN D-MODE	01295	2N4391
A58Q11	1855-0420	2		TRANSISTOR J-FET 2N4391 N-CHAN D-MODE	01295	2N4391
A58Q12	1855-0420	2		TRANSISTOR J-FET 2N4391 N-CHAN D-MODE	01295	2N4391
A58Q13	1854-0404	0	1	TRANSISTOR NPN SI TO-18 PD=360MW	28480	1854-0404
A58Q14	1854-0261	8	1	TRANSISTOR NPN 2N4239 SI TO-5 PD=6W	02037	2N4239
A58R1	2100-3154	7	1	RESISTOR-TRMR 1K 1% C SIDE-ADJ 17-TRN	02111	43P102
A58R2	0757-0280	3	9	RESISTOR 1K 1% .125W F TC=0+100	24546	C4-1/8-T0-1001-F
A58R3	0757-0416	7	2	RESISTOR 511 1% .125W F TC=0+100	24546	C4-1/8-T0-511R-F
A58R4	2100-3123	0	1	RESISTOR-TRMR 500 10% C SIDE-ADJ 17-TRN	02111	43P501
A58R5	0757-0465	6	3	RESISTOR 100K 1% .125W F TC=0+100	24546	C4-1/8-T0-1003-F
A58R6	0757-0428	1	1	RESISTOR 1.62K 1% .125W F TC=0+100	24546	C4-1/8-T0-1621-F
A58R7	0698-3155	1	2	RESISTOR 4.64K 1% .125W F TC=0+100	24546	C4-1/8-T0-4641-F
A58R8	0757-0401	0	3	RESISTOR 100 1% .125W F TC=0+100	24546	C4-1/8-T0-101F
A58R9	0699-0747	3	2	RESISTOR 4K .05% .1W F TC=0+100	28480	0699-0747
A58R10	0757-0442	9	14	RESISTOR 10K 1% .125W F TC=0+100	24546	C4-1/8-T0-1002-F
A58R11	0698-8960	6	1	RESISTOR 750K 1% .125W F TC=0+100	28480	0698-8960
A58R12	0699-0747	3		RESISTOR 4K .05% .1W F TC=0+100	28480	0699-0747
A58R13	2100-3095	5	1	RESISTOR-TRMR 200 10% C SIDE-ADJ 17-TRN	02111	43P201
A58R14	0757-0346	2	9	RESISTOR 10 1% .125W F TC=0+100	24546	C4-1/8-T0-10R0-F
A58R15	0757-0346	2		RESISTOR 10 1% .125W F TC=0+100	24546	C4-1/8-T0-10R0-F
A58R16	0757-0346	2		RESISTOR 10 1% .125W F TC=0+100	24546	C4-1/8-T0-10R0-F
A58R17	0757-0440	7	1	RESISTOR 7.5K 1% .125W F TC=0+100	24546	C4-1/8-T0-7501-F
A58R18	0757-0442	9		RESISTOR 10K 1% .125W F TC=0+100	24546	C4-1/8-T0-1002-F
A58R19	0757-0200	7	1	RESISTOR 5.62K 1% .125W F TC=0+100	24546	C4-1/8-T0-5621-F
A58R20	0757-0438	3	2	RESISTOR 5.11K 1% .125W F TC=0+100	24546	C4-1/8-T0-5111-F
A58R21	0757-0346	2		RESISTOR 10 1% .125W F TC=0+100	24546	C4-1/8-T0-10R0-F
A58R22	0757-1101	9	1	RESISTOR 360 1% .125W F TC=0+100	24546	C4-1/8-T0-361-F
A58R23	0698-3260	9	1	RESISTOR 464K 1% .125W F TC=0+100	28480	0698-3260
A58R24	0757-0458	7	2	RESISTOR 51.1K 1% .125W F TC=0+100	24546	C4-1/8-T0-5112-F
A58R25	0698-3484	9	1	RESISTOR 6.65K 1% .125W F TC=0+100	24546	C4-1/8-T0-6651-F
A58R26	0698-4503	5	1	RESISTOR 66.5K 1% .125W F TC=0+100	24546	C4-1/8-T0-6652-F
A58R27	0698-0085	0	1	RESISTOR 2.61K 1% .125W F TC=0+100	24546	C4-1/8-T0-2611-F
A58R28	0698-3453	2	1	RESISTOR 196K 1% .125W F TC=0+100	24546	C4-1/8-T0-1963-F
A58R29	0757-0290	5	1	RESISTOR 6.19K 1% .125W F TC=0+100	19701	MF4C1/8-T0-6191-F
A58R30	0698-3151	7	1	RESISTOR 2.87K 1% .125W F TC=0+100	24546	C4-1/8-T0-2871-F
A58R31	0757-0458	7		RESISTOR 51.1K 1% .125W F TC=0+100	24546	C4-1/8-T0-5112-F
A58R32	0698-5093	0	1	RESISTOR 390K 1% .125W F TC=0+100	28480	0698-5093
A58R33				NOT ASSIGNED		
A58R34	0757-0465	6		RESISTOR 100K 1% .125W F TC=0+100	24546	C4-1/8-T0-1003-F
A58R35				NOT ASSIGNED		
A58R36	0757-0199	3	1	RESISTOR 21.5K 1% .125W F TC=0+100	24546	C4-1/8-T0-2152-F
A58R37	0757-0346	2		RESISTOR 10 1% .125W F TC=0+100	24546	C4-1/8-T0-10R0-F
A58R38	0757-0346	2		RESISTOR 10 1% .125W F TC=0+100	24546	C4-1/8-T0-10R0-F
A58R39	0698-3432	7	1	RESISTOR 26.1K 1% .125W F TC=0+100	24546	C4-1/8-T0-2611-F
A58R40				NOT ASSIGNED	03888	PME55-1/8-T0-26R1-F
A58R41	0757-0442	9		RESISTOR 10K 1% .125W F TC=0+100	24546	C4-1/8-T0-1002-F
A58R42	0757-0442	9		RESISTOR 10K 1% .125W F TC=0+100	24546	C4-1/8-T0-1002-F
A58R43	0698-3136	8	1	RESISTOR 17.8K 1% .125W F TC=0+100	24546	C4-1/8-T0-1782-F
A58R44	0757-0459	8	1	RESISTOR 56.2K 1% .125W F TC=0+100	24546	C4-1/8-T0-5622-F
A58R45	0698-3155	1		RESISTOR 4.64K 1% .125W F TC=0+100	24546	C4-1/8-T0-4641-F

See introduction to this section for ordering information
 *Indicates factory selected value

Table 6-3. Replaceable Parts

Reference Designation	HP Part Number	C D	Qty	Description	Mfr Code	Mfr Part Number
A58R46	0757-0442	9		RESISTOR 10K 1% .125W F TC=0+100	24546	C4-1/8-T0-1002-F
A58R47	0757-0442	9		RESISTOR 10K 1% .125W F TC=0+100	24546	C4-1/8-T0-1002-F
A58R48	0698-3430	5	1	RESISTOR 21.5 1% .125W F TC=0+100	03888	PME55-1/8-T0-21R5-F
A58R49	0757-0289	2	1	RESISTOR 13.3K 1% .125W F TC=0+100	19701	MF4C1/8-T0-1332-F
A58R50	0757-0280	3		RESISTOR 1K 1% .125W F TC=0+100	24546	C4-1/8-T0-1001-F
A58R51				NOT ASSIGNED		
A58R52	0699-0683	6	3	RESISTOR 10K .01% .1W F TC=0+15	28480	0699-0683
A58R53	0699-0683	6		RESISTOR 10K .01% .1W F TC=0+15	28480	0699-0683
A58R54	0757-0346	2		RESISTOR 10 1% .125W F TC=0+100	24546	C4-1/8-T0-10R0-F
A58R55	0699-0683	6		RESISTOR 10K .01% .1W F TC=0+15	28480	0699-0683
A58R56	0757-0346	2		RESISTOR 10 1% .125W F TC=0+100	24546	C4-1/8-T0-10R0-F
A58R57	0699-0685	8	1	RESISTOR 2K .01% .1W F TC=0+15	28480	0699-0685
A58R58	0699-0684	7	2	RESISTOR 8.1K .01% .1W F TC=0+15	28480	0699-0684
A58R59	0699-0275	2	1	RESISTOR 1K .01% .1W F TC=0+15	28480	0699-0275
A58R60	0757-0465	6		RESISTOR 100K 1% .125W F TC=0+100	24546	C4-1/8-T0-1003-F
A58R61	0699-0684	7		RESISTOR 8.1K .01% .1W F TC=0+15	28480	0699-0684
A58R62	0699-0682	5	1	RESISTOR 900 .01% .1W F TC=0+15	28480	0699-0682
A58R63	0757-0401	0		RESISTOR 100 1% .125W F TC=0+100	24546	C4-1/8-T0-101-F
A58R64	0757-0346	2		RESISTOR 10 1% .125W F TC=0+100	24546	C4-1/8-T0-10R0-F
A58R65	0757-0442	9		RESISTOR 10K 1% .125W F TC=0+100	24546	C4-1/8-T0-1002-F
A58R66	0757-0442	9		RESISTOR 10K 1% .125W F TC=0+100	24546	C4-1/8-T0-1002-F
A58R67	0757-0442	9		RESISTOR 10K 1% .125W F TC=0+100	24546	C4-1/8-T0-1002-F
A58R68	0757-0442	9		RESISTOR 10K 1% .125W F TC=0+100	24546	C4-1/8-T0-1002-F
A58R69	0757-0442	9		RESISTOR 10K 1% .125W F TC=0+100	24546	C4-1/8-T0-1002-F
A58R70	0757-0442	9		RESISTOR 10K 1% .125W F TC=0+100	24546	C4-1/8-T0-1002-F
A58R71	0757-0442	9		RESISTOR 10K 1% .125W F TC=0+100	24546	C4-1/8-T0-1002-F
A58R72	0757-0442	9		RESISTOR 10K 1% .125W F TC=0+100	24546	C4-1/8-T0-1002-F
A58R73	0757-0280	3		RESISTOR 1K 1% .125W F TC=0+100	24546	C4-1/8-T0-1001-F
A58R74	0757-0280	3		RESISTOR 1K 1% .125W F TC=0+100	24546	C4-1/8-T0-1001-F
A58R75	0757-0280	3		RESISTOR 1K 1% .125W F TC=0+100	24546	C4-1/8-T0-1001-F
A58R76	0757-0280	3		RESISTOR 1K 1% .125W F TC=0+100	24546	C4-1/8-T0-1001-F
A58R77	0757-0280	3		RESISTOR 1K 1% .125W F TC=0+100	24546	C4-1/8-T0-1001-F
A58R78	0757-0280	3		RESISTOR 1K 1% .125W F TC=0+100	24546	C4-1/8-T0-1001-F
A58R79	0757-0416	7	1	RESISTOR 511 1% .125W F TC=0+100	24546	C4-1/8-T0-511R-F
A58R80	0757-0278	9	1	RESISTOR 1.78K 1% .125W F TC=0+100	24546	C4-1/8-T0-1781-F
A58R81	0757-0438	3		RESISTOR 5.11K 1% .125W F TC=0+100	24546	C4-1/8-T0-5111-F
A58R82				NOT ASSIGNED		
A58R83	0757-0401	0		RESISTOR 100 1% .125W F TC=0+100	24546	C4-1/8-T0-101-F
A58R84	0757-0280	3		RESISTOR 1K 1% .125W F TC=0+100	24546	C4-1/8-T0-1001-F
A58TP1	0360-0535	0	14	TERMINAL TEST POINT PCB	00000	ORDER BY DESCRIPTION
A58TP2	0360-0535	0		TERMINAL TEST POINT PCB	00000	ORDER BY DESCRIPTION
A58TP3	0360-0535	0		TERMINAL TEST POINT PCB	00000	ORDER BY DESCRIPTION
A58TP4	0360-0535	0		TERMINAL TEST POINT PCB	00000	ORDER BY DESCRIPTION
A58TP5	0360-0535	0		TERMINAL TEST POINT PCB	00000	ORDER BY DESCRIPTION
A58TP6	0360-0535	0		TERMINAL TEST POINT PCB	00000	ORDER BY DESCRIPTION
A58TP7	0360-0535	0		TERMINAL TEST POINT PCB	00000	ORDER BY DESCRIPTION
A58TP8	0360-0535	0		TERMINAL TEST POINT PCB	00000	ORDER BY DESCRIPTION
A58TP9	0360-0535	0		TERMINAL TEST POINT PCB	00000	ORDER BY DESCRIPTION
A58TP10	0360-0535	0		TERMINAL TEST POINT PCB	00000	ORDER BY DESCRIPTION
A58TP11	0360-0535	0		TERMINAL TEST POINT PCB	00000	ORDER BY DESCRIPTION
A58TP12	0360-0535	0		TERMINAL TEST POINT PCB	00000	ORDER BY DESCRIPTION
A58TP13	0360-0535	0		TERMINAL TEST POINT PCB	00000	ORDER BY DESCRIPTION
A58TP14	0360-0535	0		TERMINAL TEST POINT PCB	00000	ORDER BY DESCRIPTION
A58U1	1826-0471	2	9	IC OP AMP LOW-DRIFT TO-99 PKG	28480	1826-0471
A58U2	1820-1984	2	1	IC CONV 10-B-D/A 16-DIP-C PKG	24355	AD561KD
A58U3	1810-0206	8	7	NETWORK-RES 8-SIP10.0K OHM X 7	01121	208A103
A58U4	1826-0138	8	3	IC COMPARATOR GP QUAD 14-DIP-P PKG	01295	LM339N
A58U5	1826-0938	6	1	D/A 10-bit 18-CERDIP BPLR	28480	1826-0938
A58U6	1826-0471	2		IC OP AMP LOW-DRIFT TO-99 PKG	28480	1826-0471
A58U7	1826-0471	2		IC OP AMP LOW-DRIFT TO-99 PKG	28480	1826-0471
A58U8	1826-0471	2		IC OP AMP LOW-DRIFT TO-99 PKG	28480	1826-0471
A58U9	1813-0041	5	1	IC OP AMP TO-99 PKG	27014	LH0042CH
A58U10	1826-0785	1	1	IC OP AMP LOW-BIAS-H-IMPD DUAL 8-DIP-C	01295	TL072ACJG
A58U11	1826-0684	9	1	IC CONV 12-B-D/A 18 DIP-C PKG	28480	1826-0684
A58U12	1826-0471	2		IC OP AMP LOW-DRIFT TO-99 PKG	28480	1826-0471
A58U13	1826-1140	4	1	IC SMP/L/HOLD 14 CERDIP	02180	SMP-10FT
A58U14	1826-0471	2		IC OP AMP LOW-DRIFT TO-99 PKG	28480	1826-0471
A58U15	1826-0783	9	1	IC OP AMP LOW-NOIS 8-DIP-C PKG	52063	XR5534ACN
A58U16	1826-0471	2		IC OP AMP LOW-DRIFT TO-99 PKG	28480	1826-0471
A58U17	1826-0471	2		IC OP AMP LOW-DRIFT TO-99 PKG	28480	1826-0471
A58U18	1826-0471	2		IC OP AMP LOW-DRIFT TO-99 PKG	28480	1826-0471
A58U19	1810-0206	8		NETWORK-RES 8-SIP10.0K OHM X 7	01121	208A103
A58U20	1820-1196	8	6	IC FF TTL LS D-TYPE POS-EDGE-TRIG COM	01295	SN74LS174N

See introduction to this section for ordering information
 *Indicates factory selected value

Table 6-3. Replaceable Parts

Reference Designation	HP Part Number	C D	Qty	Description	Mfr Code	Mfr Part Number
A58U21	1810-0206	8		NETWORK-RES 8-SIP10.0K OHM X 7	01121	208A103
A58U22	1820-1196	8		IC FF TTL LS D-TYPE POS-EDGE-TRIG COM	01295	SN74LS174N
A58U23	1820-2550	0	2	IC DCDR TTL LS 3-TO-8-LINE	01295	SN74LS137N
A58U24	1810-0206	8		NETWORK-RES 8-SIP10.0K OHM X 7	01121	208A103
A58U25	1820-1196	8		IC FF TTL LS D-TYPE POS-EDGE-TRIG COM	01295	SN74LS174N
A58U26	1810-0206	8		NETWORK-RES 8-SIP10.0K OHM X 7	01121	208A103
A58U27	1820-1196	8		IC FF TTL LS D-TYPE POS-EDGE-TRIG COM	01295	SN74LS174N
A58U28	1810-0206	8		NETWORK-RES 8-SIP10.0K OHM X 7	01121	208A103
A58U29	1820-1196	8		IC FF TTL LS D-TYPE POS-EDGE-TRIG COM	01295	SN74LS174N
A58U30	1810-0206	8		NETWORK-RES 8-SIP10.0K OHM X 7	01121	208A103
A58U31	1820-1196	8		IC FF TTL LS D-TYPE POS-EDGE-TRIG COM	01295	SN74LS174N
A58U32	1820-1197	9	1	IC GATE TTL LS NAND QUAD 2-INP	01295	SN74LS00N
A58U33	1820-1425	6	1	IC SCHMITT-TRIG TTL LS NAND QUAD 2-INP	01295	SN74LS132N
A58U34	1820-2550	0		IC DCDR TTL LS 3-TO-8-LINE	01295	SN74LS137N
A58U35	1826-0138	8		IC COMPARATOR GP QUAD 14-DIP-P PKG	01295	LM339N
A58U36	1810-0371	8	1	NETWORK-RES 8-SIP100.0K OHM X7	01121	208A104
A58U37	1826-0138	8		IC COMPARATOR GP QUAD 14-DIP-P PKG	01295	LM339N
A58VR1	1902-0625	0	1	DIODE-ZNR 1N829 6.2V 58 DO-7 PD=.25W	04713	1N829

See introduction to this section for ordering information
 *Indicates factory selected value

Table 6-3. Replaceable Parts

Reference Designation	HP Part Number	C D	Qty	Description	Mfr Code	Mfr Part Number
A59	08340-60226	1	1	DIGITAL INTERFACE	28480	08340-60226
A59C1	0180-0229	6	1	CAPACITOR-FXD 22UF+-10% 15VDC TA	56289	150D226X9015B2
A59C2	0160-4557	0	3	CAPACITOR-FXD .1UF +-20% 50VDC CER	16299	CAC04X7R104M050A
A59C3	0160-4557	0		CAPACITOR-FXD .1UF +-20% 50VDC CER	16299	CAC04X7R104M050A
A59C4	0160-4557	0		CAPACITOR-FXD .1UF +-20% 50VDC CER	16299	CAC04X7R104M050A
A59C5		0		NOT ASSIGNED		
A59C6	0160-4832	4	11	CAPACITOR-FXD .01UF +-10% 100VDC CER	28480	0160-4832
A59C7	0160-4832	4		CAPACITOR-FXD .01UF +-10% 100VDC CER	28480	0160-4832
A59C8	0160-4832	4		CAPACITOR-FXD .01UF +-10% 100VDC CER	28480	0160-4832
A59C9	0160-4832	4		CAPACITOR-FXD .01UF +-10% 100VDC CER	28480	0160-4832
A59C10	0160-4832	4		CAPACITOR-FXD .01UF +-10% 100VDC CER	28480	0160-4832
A59C11	0160-4832	4		CAPACITOR-FXD .01UF +-10% 100VDC CER	28480	0160-4832
A59C12	0160-4832	4		CAPACITOR-FXD .01UF +-10% 100VDC CER	28480	0160-4832
A59C13	0160-4832	4		CAPACITOR-FXD .01UF +-10% 100VDC CER	28480	0160-4832
A59C14				NOT ASSIGNED		
A59C15				NOT ASSIGNED		
A59C16	0160-4832	4		CAPACITOR-FXD .01UF +-10% 100VDC CER	28480	0160-4832
A59C17	0160-4832	4		CAPACITOR-FXD .01UF +-10% 100VDC CER	28480	0160-4832
A59C18	0160-4832	4		CAPACITOR-FXD .01UF +-10% 100VDC CER	28480	0160-4832
A59CR1	1901-0033	2	3	DIODE-GEN PRP 180V 200MA DO-7	28480	1901-0033
A59CR2	1901-0033	2		DIODE-GEN PRP 180V 200MA DO-7	28480	1901-0033
A59CR3	1901-0033	2		DIODE-GEN PRP 180V 200MA DO-7	28480	1901-0033
A59L1	9100-1788	6	1	CHOKE-WIDE BAND ZMAX=680 OHM@ 180 MHZ	02114	VK200 20/48
A59MP1	4040-0756	3	1	EXTR-PC BD WHT POLYC .062-BD-THKNS	28480	4040-0756
A59MP2_3	1480-0073	6	2	PIN-ROLL .062-IN-DIA .25-IN-LG BE-CU	28480	1480-0073
A59MP4	4040-0753	0	1	EXTR-PC BD GRN POLYC .062-BD-THKNS	28480	4040-0753
A59P1	1251-7469	3	1		28480	1251-7469
A59R1	0757-1094	9	1	RESISTOR 1.47K 1% .125W F TC=0+-100	24546	C4-1/8-T0-1471-F
A59R2	0757-0462	3	1	RESISTOR 75K 1% .125W F TC=0+-100	24546	C4-1/8-T0-7502-F
A59R3	0757-0199	3	1	RESISTOR 21.5K 1% .125W F TC=0+-100	24546	C4-1/8-T0-2152-F
A59R4	0698-3154	0	1	RESISTOR 4.22K 1% .125W F TC=0+-100	24546	C4-1/8-T0-4221-F
A59R5	0757-0442	9	5	RESISTOR 10K 1% .125W F TC=0+-100	24546	C4-1/8-T0-1002-F
A59R6	0698-3160	8	1	RESISTOR 31.6K 1% .125W F TC=0+-100	24546	C4-1/8-T0-3162-F
A59R7	0698-3446	3	3	RESISTOR 383 1% .125W F TC=0+-100	03292	C4-1/8-T0-383R-F
A59R8	0698-3446	3		RESISTOR 383 1% .125W F TC=0+-100	03292	C4-1/8-T0-383R-F
A59R9	0698-3446	3		RESISTOR 383 1% .125W F TC=0+-100	03292	C4-1/8-T0-383R-F
A59R10	0698-0083	8	2	RESISTOR 1.96K 1% .125W F TC=0+-100	24546	C4-1/8-T0-1961-F
A59R11	0757-0442	9		RESISTOR 10K 1% .125W F TC=0+-100	24546	C4-1/8-T0-1002-F
A59R12	0757-0442	9		RESISTOR 10K 1% .125W F TC=0+-100	24546	C4-1/8-T0-1002-F
A59R13				NOT ASSIGNED		
A59R14	0698-0083	8		RESISTOR 1.96K 1% .125W F TC=0+-100	24546	C4-1/8-T0-1961-F
A59R15-.21				NOT ASSIGNED		
A59R22	0757-0442	9		RESISTOR 10K 1% .125W F TC=0+-100	24546	C4-1/8-T0-1002-F
A59R23-.24				NOT ASSIGNED		
A59R26-.28				NOT ASSIGNED		
A59R29	0757-0422	5	3	RESISTOR 909 1% .125W F TC=0+-100	03292	CT4-1/8-T0-909R-F
A59R30	0757-0422	5		RESISTOR 909 1% .125W F TC=0+-100	03292	CT4-1/8-T0-909R-F
A59R31	0757-0422	5		RESISTOR 909 1% .125W F TC=0+-100	03292	CT4-1/8-T0-909R-F
A59R32				NOT ASSIGNED		
A59R33	0757-0438	3	1	RESISTOR 5.11K 1% .125W F TC=0+-100	03292	CT4-1/8-T0-5111-F
A59TP1	0360-0535	0	10	TERMINAL TEST POINT PCB	00000	ORDER BY DESCRIPTION
A59TP2	0360-0535	0		TERMINAL TEST POINT PCB	00000	ORDER BY DESCRIPTION
A59TP3	0360-0535	0		TERMINAL TEST POINT PCB	00000	ORDER BY DESCRIPTION
A59TP4	0360-0535	0		TERMINAL TEST POINT PCB	00000	ORDER BY DESCRIPTION
A59TP5	0360-0535	0		TERMINAL TEST POINT PCB	00000	ORDER BY DESCRIPTION
A59TP6	0360-0535	0		TERMINAL TEST POINT PCB	00000	ORDER BY DESCRIPTION
A59TP7	0360-0535	0		TERMINAL TEST POINT PCB	00000	ORDER BY DESCRIPTION
A59TP8	0360-0535	0		TERMINAL TEST POINT PCB	00000	ORDER BY DESCRIPTION
A59TP9	0360-0535	0		TERMINAL TEST POINT PCB	00000	ORDER BY DESCRIPTION
A59TP10	0360-0535	0		TERMINAL TEST POINT PCB	00000	ORDER BY DESCRIPTION
A59U1				NOT ASSIGNED		
A59U2	1820-0577	7	2	IC INV TTL HEX 1-INP	01295	SN7416N
A59U3	1820-1416	5	1	IC SCHMITT-TRIG TTL LS INV HEX 1-INP	01295	SN74LS14N
A59U4	1820-1440	5	2	IC LCH TTL LS QUAD	01295	SN74LS279N
A59U5	1820-1905	7	1	IC GATE TTL LS NOR DUAL 5-INP	07263	74LS260PC
A59U6	1820-1297	0	1	IC GATE TTL LS EXCL-NOR QUAD 2-INP	01295	SN74LS266N
A59U7	1820-2024	3	1	IC DRVR TTL LS LINE DRVR OCTL	01295	SN74LS244N
A59U8				NOT ASSIGNED		
A59U9	1820-0577	7		IC INV TTL HEX 1-INP	01295	SN7416N
A59U10	1820-1196	8	3	IC FF TTL LS D-TYPE POS-EDGE-TRIG COM	01295	SN74LS174N
A59U11	1820-1210	7	2	IC GATE TTL LS AND-OR-INV DUAL 2-INP	01295	SN74LS51N
A59U12	1820-1216	3	3	IC DCDR TTL LS 3-TO-8-LINE 3-INP	01295	SN74LS138N
A59U13	1826-0138	8	1	IC COMPARATOR GP QUAD 14-DIP-P PKG	01295	LM339N
A59U14-17				NOT ASSIGNED		
A59U17	1820-1196	8		IC FF TTL LS D-TYPE POS-EDGE-TRIG COM	01295	SN74LS174N
A59U18	1820-1917	1	1	IC BFR TTL LS LINE DRVR OCTL	01295	SN74LS240N

See instruction to this section for ordering information.

*Indicates factory selected value.

Table 6-3. Replaceable Parts

Reference Designation	HP Part Number	C D	Qty	Description	Mfr Code	Mfr Part Number
A59U19 A59U20	1820-1216	3		IC DCDR TTL LS 3-TO-8-LINE 3-INP NOT ASSIGNED	01295	SN74LS138N
A59U21	1820-1440	5		NOT ASSIGNED		
A59U22	1820-1440	5		IC LCH TTL LS QUAD	01295	SN74LS279N
A59U23	1820-1858	9	2	IC FF TTL LS D-TYPE OCTL	01295	SN74LS377N
A59U24	1820-1858	9		IC FF TTL LS D-TYPE OCTL	01295	SN74LS377N
A59U25	1820-1210	7		IC GATE TTL LS AND-OR-INV DUAL 2-INP	01295	SN74LS51N
A59U26	1820-1216	3		IC DCDR TTL LS 3-TO-8-LINE 3-INP	01295	SN74LS138N
A59U27	1810-0280	8	1	NETWORK-RES 10-SIP10.0K OHM X 9	01121	210A103
A59W1	1460-1489	8	3	WIREFORM BE CU AG	28480	1460-1489
A59W2	1460-1489	8		WIREFORM BE CU AG	28480	1460-1489
A59W3	1460-1489	8		WIREFORM BE CU AG	28480	1460-1489

See introduction to this section for ordering information.

*Indicates factory selected value.

Table 6-3. Replaceable Parts

Reference Designation	HP Part Number	C D	Qty	Description	Mfr Code	Mfr Part Number
A60	08340-60193	1	1	PROCESSOR BOARD ASSEMBLY	28480	08340-60193
A60BT1	1420-0331	3	1	BATTERY 3.4V 1.75A-HR LITHIUM THIONYL	28480	1420-0331
A60C1	0180-0374	3	3	CAPACITOR-FXD 10UF+-10% 20VDC TA	56289	150D106X9020B2
A60C2	0180-0374	3	3	CAPACITOR-FXD 10UF+-10% 20VDC TA	56289	150D106X9020B2
A60C3	0180-0374	3		CAPACITOR-FXD 10UF+-10% 20VDC TA	56289	150D106X9020B2
A60C4	0160-4835	7	19	CAPACITOR-FXD .1UF +-10% 50VDC CER	28480	0160-4835
A60C5	0160-4835	7		CAPACITOR-FXD .1UF +-10% 50VDC CER	28480	0160-4835
A60C6	0180-0291	3	1	CAPACITOR-FXD 1UF+-10% 35VDC TA	56289	150D105X9035A2
A60C7	0160-4835	7		CAPACITOR-FXD .1UF +-10% 50VDC CER	28480	0160-4835
A60C8	0160-4835	7		CAPACITOR-FXD .1UF +-10% 50VDC CER	28480	0160-4835
A60C9	0160-4835	7		CAPACITOR-FXD .1UF +-10% 50VDC CER	28480	0160-4835
A60C10	0160-4835	7		CAPACITOR-FXD .1UF +-10% 50VDC CER	28480	0160-4835
A60C11	0160-4832	4	11	CAPACITOR-FXD .01UF +-10% 100VDC CER	28480	0160-4832
A60C12	0160-4835	7		CAPACITOR-FXD .1UF +-10% 50VDC CER	28480	0160-4835
A60C13	0160-4835	7		CAPACITOR-FXD .1UF +-10% 50VDC CER	28480	0160-4835
A60C14	0160-4835	7		CAPACITOR-FXD .1UF +-10% 50VDC CER	28480	0160-4835
A60C15	0160-4835	7		CAPACITOR-FXD .1UF +-10% 50VDC CER	28480	0160-4835
A60C16	0160-4835	7		CAPACITOR-FXD .1UF +-10% 50VDC CER	28480	0160-4835
A60C17	0160-4835	7		CAPACITOR-FXD .1UF +-10% 50VDC CER	28480	0160-4835
A60C18	0160-4835	7		CAPACITOR-FXD .1UF +-10% 50VDC CER	28480	0160-4835
A60C19	0160-4835	7		CAPACITOR-FXD .1UF +-10% 50VDC CER	28480	0160-4835
A60C20	0160-4835	7		CAPACITOR-FXD .1UF +-10% 50VDC CER	28480	0160-4835
A60C21	0160-4835	7		CAPACITOR-FXD .1UF +-10% 50VDC CER	28480	0160-4835
A60C22	0160-4835	7		CAPACITOR-FXD .1UF +-10% 50VDC CER	28480	0160-4835
A60C23	0160-4835	7		CAPACITOR-FXD .1UF +-10% 50VDC CER	28480	0160-4835
A60C24	0160-4835	7		CAPACITOR-FXD .1UF +-10% 50VDC CER	28480	0160-4835
A60C25	0160-4832	4		CAPACITOR-FXD .01UF +-10% 100VDC CER	28480	0160-4832
A60C26	0160-4832	4		CAPACITOR-FXD .01UF +-10% 100VDC CER	28480	0160-4832
A60C27	0160-4832	4		CAPACITOR-FXD .01UF +-10% 100VDC CER	28480	0160-4832
A60C28	0160-4832	4		CAPACITOR-FXD .01UF +-10% 100VDC CER	28480	0160-4832
A60C29	0160-4832	4		CAPACITOR-FXD .01UF +-10% 100VDC CER	28480	0160-4832
A60C30	0160-4832	4		CAPACITOR-FXD .01UF +-10% 100VDC CER	28480	0160-4832
A60C31	0160-4832	4		CAPACITOR-FXD .01UF +-10% 100VDC CER	28480	0160-4832
A60C32	0160-4832	4		CAPACITOR-FXD .01UF +-10% 100VDC CER	28480	0160-4832
A60C33	0160-4832	4		CAPACITOR-FXD .01UF +-10% 100VDC CER	28480	0160-4832
A60C34	0160-4801	4	1	CAPACITOR-FXD 100PF +-5% 100VDC CER	28480	0160-4801
A60C35	0160-4832	4		CAPACITOR-FXD .01UF +-10% 100VDC CER	28480	0160-4832
A60CR1	1901-0376	6	2	DIODE-GEN PRP 35V 50MA DO-35	28480	1901-0376
A60CR2	1901-0376	6		DIODE-GEN PRP 35V 50MA DO-35	28480	1901-0376
A60CR3	1901-0518	8	1	DIODE-SM SIG SCHOTTKY	28480	1901-0518
A60CR4	1901-0050	3	2	DIODE-SWITCHING 80V 200MA 2NS DO-35	28480	1901-0050
A60CR5	1901-0050	3		DIODE-SWITCHING 80V 200MA 2NS DO-35	28480	1901-0050
A60CR6	1901-1098	1	2	DIODE-SWITCHING 50V 200MA 4NS	02682	1N4150
A60CR7	1901-1098	1		DIODE-SWITCHING 50V 200MA 4NS	02682	1N4150
A60DS1	1990-0958	7	16	LED-LAMP IF=7MA-MAX BVR=5V	28480	1990-0958
A60DS2	1990-0958	7		LED-LAMP IF=7MA-MAX BVR=5V	28480	1990-0958
A60DS3	1990-0958	7		LED-LAMP IF=7MA-MAX BVR=5V	28480	1990-0958
A60DS4	1990-0958	7		LED-LAMP IF=7MA-MAX BVR=5V	28480	1990-0958
A60DS5	1990-0958	7		LED-LAMP IF=7MA-MAX BVR=5V	28480	1990-0958
A60DS6	1990-0958	7		LED-LAMP IF=7MA-MAX BVR=5V	28480	1990-0958
A60DS7	1990-0958	7		LED-LAMP IF=7MA-MAX BVR=5V	28480	1990-0958
A60DS8	1990-0958	7		LED-LAMP IF=7MA-MAX BVR=5V	28480	1990-0958
A60DS9	1990-0958	7		LED-LAMP IF=7MA-MAX BVR=5V	28480	1990-0958
A60DS10	1990-0958	7		LED-LAMP IF=7MA-MAX BVR=5V	28480	1990-0958
A60DS11	1990-0958	7		LED-LAMP IF=7MA-MAX BVR=5V	28480	1990-0958
A60DS12	1990-0958	7		LED-LAMP IF=7MA-MAX BVR=5V	28480	1990-0958
A60DS13	1990-0958	7		LED-LAMP IF=7MA-MAX BVR=5V	28480	1990-0958
A60DS14	1990-0958	7		LED-LAMP IF=7MA-MAX BVR=5V	28480	1990-0958
A60DS15	1990-0958	7		LED-LAMP IF=7MA-MAX BVR=5V	28480	1990-0958
A60DS16	1990-0958	7		LED-LAMP IF=7MA-MAX BVR=5V	28480	1990-0958
A60DS17	1990-0487	7	1	LED-LAMP LUM-INT=1MCD IF=20MA-MAX BVR=5V	28480	5082-4584
A60L1	9100-1788	6	1	CHOKE-WIDE BAND ZMAX=680 OHM@ 180 MHZ	02114	VK200 20/48
A60MP1	4040-0754	1	1	EXTR PC BD BLU	28480	4040-0754
A60MP2	4040-0748	3	1	EXTR PC BD BLK	28480	4040-0748
A60MP3,4	1480-0073	6	2	PIN-ROLL .062-IN-DIA .25-IN-LG BE-CU	28480	1480-0073
A60MP5	1400-1267	4	1	CLIP BTRY AA	28480	1400-1267
A60P1	1251-7469	3	1	CONN-POST TYPE .100-PIN-SPCG 110-CONT	28480	1251-7469
A60Q1	1853-0281	9	2	TRANSISTOR PNP 2N2907A SI TO-18 PD=400MW	04713	2N2907A
A60Q2	1854-0477	7	1	TRANSISTOR NPN 2N2222A SI TO-18 PD=500MW	04713	2N2222A
A60Q3	1853-0281	9		TRANSISTOR PNP 2N2907A SI TO-18 PD=400MW	04713	2N2907A
A60R1	0757-0873	0	1	RESISTOR 1.62K 1% .5W F TC=0+-100	28480	0757-0873
A60R2	0757-0280	3	2	RESISTOR 1K 1% .125W F TC=0+-100	24546	C4-1/8-T0-1001-F
A60R3	0757-0442	9	10	RESISTOR 10K 1% .125W F TC=0+-100	24546	C4-1/8-T0-1002-F
A60R4	0698-3157	3	2	RESISTOR 19.6K 1% .125W F TC=0+-100	24546	C4-1/8-T0-1962-F
A60R5	0757-0442	9		RESISTOR 10K 1% .125W F TC=0+-100	24546	C4-1/8-T0-1002-F
A60R6	0757-0290	5	1	RESISTOR 6.19K 1% .125W F TC=0+-100	19701	MF4C1/B-T0-6191-F
A60R7	0698-3152	8	1	RESISTOR 3.48K 1% .125W F TC=0+-100	24546	C4-1/8-T0-3481-F
A60R8	0698-3153	9	1	RESISTOR 3.83K 1% .125W F TC=0+-100	24546	C4-1/8-T0-3831-F
A60R9	0698-3260	9	3	RESISTOR 464K 1% .125W F TC=0+-100	28480	0698-3260

See immediately to this section for ordering information.

*Indicates factory selected value.

Table 6-3. Replaceable Parts

Reference Designation	HP Part Number	C D	Qty	Description	Mfr Code	Mfr Part Number
A60R10	0757-0280	3		RESISTOR 1K 1% .125W F TC=0+-100	24546	C4-1/B-T0-1001-F
A60R11	0757-0442	9		RESISTOR 10K 1% .125W F TC=0+-100	24546	C4-1/B-T0-1002-F
A60R12	0757-0442	9		RESISTOR 10K 1% .125W F TC=0+-100	24546	C4-1/B-T0-1002-F
A60R13	0757-0442	9		RESISTOR 10K 1% .125W F TC=0+-100	24546	C4-1/B-T0-1002-F
A60R14	0698-3260	9		RESISTOR 464K 1% .125W F TC=0+-100	28480	0698-3260
A60R15	0698-3260	9		RESISTOR 464K 1% .125W F TC=0+-100	28480	0698-3260
A60R16	0757-0401	0	1	RESISTOR 10K 1% .125W F TC=0+-100	24546	C4-1/B-T0-101-F
A60R17	0757-0438	3	3	RESISTOR 5.11K 1% .125W F TC=0+-100	24546	C4-1/B-T0-5111-F
A60R18	0757-0438	3		RESISTOR 5.11K 1% .125W F TC=0+-100	24546	C4-1/B-T0-5111-F
A60R19	0757-0416	7	2	RESISTOR 511 1% .125W F TC=0+-100	24546	C4-1/B-T0-511R-F
A60R20	0757-0442	9		RESISTOR 10K 1% .125W F TC=0+-100	24546	C4-1/B-T0-1002-F
A60R21	0757-0442	9		RESISTOR 10K 1% .125W F TC=0+-100	24546	C4-1/B-T0-1002-F
A60R22				NOT ASSIGNED		
A60R23	0757-0442	9		RESISTOR 10K 1% .125W F TC=0+-100	24546	C4-1/B-T0-1002-F
A60R24	0757-0442	9		RESISTOR 10K 1% .125W F TC=0+-100	24546	C4-1/B-T0-1002-F
A60R25	0757-0442	9		RESISTOR 10K 1% .125W F TC=0+-100	24546	C4-1/B-T0-1002-F
A60R26	0698-3155	1	2	RESISTOR 4.64K 1% .125W F TC=0+-100	24546	C4-1/B-T0-4641-F
A60R27	0698-3155	1		RESISTOR 4.64K 1% .125W F TC=0+-100	24546	C4-1/B-T0-4641-F
A60R28	0757-0416	7		RESISTOR 511 1% .125W F TC=0+-100	24546	C4-1/B-T0-511R-F
A60R29	0757-0438	3		RESISTOR 5.11K 1% .125W F TC=0+-100	24546	C4-1/B-T0-5111-F
A60R30	0698-3157	3		RESISTOR 19.6K 1% .125W F TC=0+-100	24546	C4-1/B-T0-1962-F
A60TP1-TP26	0360-0535	0	26	TERMINAL TEST POINT PCB		ORDER BY DESCRIPTION
A60U1	1826-0759	9	1	IC COMPARATOR GP QUAD 14-DIP-C PKG	00000	LM339J
A60U2	1810-0206	8	1	NETWORK-RES 8-SIP10.0K OHM X 7	01713	208A103
A60U3	1813-0196	1	1	XTAL-CLOCK-OSCILLATOR 14.7456-MHZ	01121	1813-0196
A60U4	1820-3449	8	1	IC-PARALLEL INTERFACE/TIMER/BMHZ/MC68000	28480	1820-3449
A60U5	1820-3172	4	1	IC FF CMOS/74HC J-K BAR POS-EDGE-TRIG	28480	1820-3172
A60U6	1820-2483	8	1	IC RCVR TTL LS BUS OCTL	01295	SN75161N
A60U7	1820-2485	0	1	IC RCVR TTL LS BUS OCTL	01295	SN75160N
A60U8	1820-3401	2	1	IC BFR TTL ALS OR QUAD 2-INP	28480	1820-3401
A60U9	1810-0276	2	2	NETWORK-RES 10-SIP1.5K OHM X 9	01121	210A152
A60U10	08340-80005	6	1	IC DECODER	28480	08340-80005
A60U11	1820-2548	6	1	IC GENERAL PURPOSE INTERFACE BUS ADAPTER	28480	1820-2548
A60U12	1810-0276	2	2	NETWORK-RES 10-SIP1.5K OHM X 9	01121	210A152
A60U13	1820-1112	8	1	IC FF TTL LS D-TYPE POS-EDGE-TRIG	01295	SN74LS74AN
A60U14	1820-1997	7	3	IC FF TTL LS D-TYPE POS-EDGE-TRIG PRL-IN	01295	SN74LS374N
A60U15	1810-0279	5	4	NETWORK-RES 10-SIP4.7K OHM X 9	01121	210A472
A60U16	1820-1997	7		IC FF TTL LS D-TYPE POS-EDGE-TRIG PRL-IN	01295	SN74LS374N
A60U17	1810-0279	5		NETWORK-RES 10-SIP4.7K OHM X 9	01121	210A472
A60U18	1820-2675	0	2	IC RCVR TTL LS BUS OCTL	01295	SN74LS646N
A60U19	1820-2675	0		IC RCVR TTL LS BUS OCTL	01295	SN74LS646N
A60U20	1820-1203	8	1	IC GATE TTL LS AND TPL 3-INP	01295	SN74LS11N
A60U21	1820-2102	8	1	IC LCH TTL LS D-TYPE OCTL	01295	SN74LS373N
A60U22	1820-1997	7		IC FF TTL LS D-TYPE POS-EDGE-TRIG PRL-IN	01295	SN74LS374N
A60U23	08340-80007	8	1	DECODER	28480	08340-80007
A60U24	1820-1851	2	1	IC ENCDR TTL LS	01295	SN74LS148N
A60U25	1820-2656	7	1	IC GATE TTL ALS NAND QUAD 2-INP	01295	SN74ALS00N
A60U26	1810-0279	5	1	NETWORK-RES 10-SIP4.7K OHM X 9	01121	210A472
A60U27	1820-2505	5	1	IC -MPU; CLK FREQ=8MHZ, INSTRUCTION	28480	1820-2505
A60U28	1820-1492	7	1	IC BFR TTL LS INV HEX 1-INP	01698	SN74LS368AN
A60U29	08340-80006	7	1	MEMORY DECODER	28480	08340-80006
A60U30	1810-0205	7	1	NETWORK-RES 8-SIP4.7K OHM X 7	01121	208A472
A60U31	1810-0279	5	1	NETWORK-RES 10-SIP4.7K OHM X 9	01121	210A472
A60U32	1818-3464	2	2	IC EPROM 2KX8	28480	1818-3464
A60U33	1818-3464	2	2	IC EPROM 2KX8	28480	1818-3464
A60U34				NOT ASSIGNED		
A60U35				NOT ASSIGNED		
A60U36	1818-3329	8	2	IC NMOS 262144(256K) EPROM 200-NS 3-S	28480	1818-3329
A60U37	1818-3329	8		IC NMOS 262144(256K) EPROM 200-NS 3-S	28480	1818-3329
A60U38	1818-3183	8	2	IC CMOS 65536 (64K) STAT RAM 150-NS 3-S	28480	1818-3183
A60U39	1818-3183	2		IC CMOS 65536 (64K) STAT RAM 150-NS 3-S	28480	1818-3183
A60U40	1251-4787	2	1	SHUNT-DIP 8-POSITION	28480	1251-4787
A60VR1	1902-3107	9	1	DIODE-ZNR 5.76V 2% DO-35 PD=4W	28480	1902-3107
A60X1	1200-0607	0	1	SOCKET-IC 16-CONT DIP DIP-SLDR	28480	1200-0607

See Introduction to this section for ordering information.

*Indicates factory selected value.

PAGES 6-127 THROUGH 6-130 HAVE BEEN INTENTIONALLY OMITTED

Table 6-3. Replaceable Parts

Reference Designation	HP Part Number	C D	Qty	Description	Mfr Code	Mfr Part Number
A62				MOTHERBOARD NOTE THIS ASSEMBLY IS NOT FIELD REPLACEABLE. A FAULTY MOTHERBOARD MUST BE REPLACED AT THE FACTORY.		
A62C1	0180-3205	5	1	CAPACITOR-FXD 4200UF +75-10% 75VAC AL	28480	0180-3205
A62C2	0180-3017	7	2	CAPACITOR-FXD .045F +75-10% 25VDC AL	28480	0180-3017
A62C3	0180-3017	7		CAPACITOR-FXD .045F +75-10% 25VDC AL	28480	0180-3017
A62C4				NOT ASSIGNED		
A62C5	0160-3879	7	1	CAPACITOR-FXD .01UF +-20% 100VDC CER	28480	0160-3879
A62C6	0180-0374	3	1	CAPACITOR-FXD 10UF +-10% 20VDC TA	56289	150D106X9020B2
A62C7	0180-2661	5	1	CAPACITOR-FXD 1UF +-10% 50VDC TA	25088	D1R0GS1A50K
A62CR1	1901-0028	5	2	DIODE-PWR RECT 400V 750MA DO-29	28480	1901-0028
A62CR2	1901-0028	5		DIODE-PWR RECT 400V 750MA DO-29	28480	1901-0028
A62CR3	1901-0033	2	1	DIODE-GEN PRP 180V 200MA DO-7	28480	1901-0033
A62DS1	1990-0486	6	1	LED-LAMP LUM-INT=1MCD IF=20MA-MAX BVR=5V	28480	5082-4684
A62J1				(NOT REPLACEABLE P/U M/B)		
A62J2	1251-5799	8	1	CONNECTOR 20-PIN M POST TYPE	28480	1251-5799
A62J3	1251-6868	4	2	CONNECTOR 5-PIN M POST TYPE	28480	1251-6868
A62J4	1250-0543	8	1	CONNECTOR-RF SM-SNP M PC 50-OHM	28480	1250-0543
A62J5	1250-1889	7	13	CONNECTOR-RF SMB M PC 50-OHM	28480	1250-1889
A62J6	1250-1889	7		CONNECTOR-RF SMB M PC 50-OHM	28480	1250-1889
A62J7	1251-7482	0	1		28480	1251-7482
A62J8	1250-1889	7		CONNECTOR-RF SMB M PC 50-OHM	28480	1250-1889
A62J9	1250-1889	7		CONNECTOR-RF SMB M PC 50-OHM	28480	1250-1889
A62J10	1250-1889	7		CONNECTOR-RF SMB M PC 50-OHM	28480	1250-1889
A62J11	1250-1889	7		CONNECTOR-RF SMB M PC 50-OHM	28480	1250-1889
A62J12				NOT ASSIGNED		
A62J13	1250-1889	7		CONNECTOR-RF SMB M PC 50-OHM	28480	1250-1889
A62J14	1250-1889	7		CONNECTOR-RF SMB M PC 50-OHM	28480	1250-1889
A62J15	1250-1889	7		CONNECTOR-RF SMB M PC 50-OHM	28480	1250-1889
A62J16	1250-1889	7		CONNECTOR-RF SMB M PC 50-OHM	28480	1250-1889
A62J17				NOT ASSIGNED		
A62J18	1200-0482	9	2	SOCKET-IC 16-CONT DIP-SLDR	28480	1200-0482
A62J19	1200-0482	9		SOCKET-IC 16-CONT DIP-SLDR	28480	1200-0482
A62J20	1200-0483	0	1	SOCKET-IC 14-CONT DIP-SLDR	28480	1200-0483
A62J21-24				NOT ASSIGNED		
A62J25	1250-1889	7		CONNECTOR-RF SMB M PC 50-OHM	28480	1250-1889
A62J26	1250-1889	7		CONNECTOR-RF SMB M PC 50-OHM	28480	1250-1889
A62J27	1250-1889	7		CONNECTOR-RF SMB M PC 50-OHM	28480	1250-1889
A62J28				NOT ASSIGNED		
A62J29	1251-6868	4		CONNECTOR 5-PIN M POST TYPE	28480	1251-6868
A62J30	1251-6795	6	2	CONNECTOR 3-PIN M POST TYPE	28480	1251-6795
A62J31	1251-8458	2	1	CONNECTOR 36-PIN M POST TYPE	28480	1251-8458
A62J32	1251-6794	5	1	CONNECTOR 5-PIN M POST TYPE	28480	1251-6794
A62J33				NOT ASSIGNED		
A62J34	1251-6795	6		CONNECTOR 3-PIN M POST TYPE	28480	1251-6795
A62K1	0490-0618	5	1	RELAY 2C 24VDC-COIL 5A 115VAC	28480	0490-0618
A62L1	85660-80007	7	8	INDUCT P/S FLTR	28480	85660-80007
A62L2	85660-80007	7		INDUCT P/S FLTR	28480	85660-80007
A62L3	85660-80007	7		INDUCT P/S FLTR	28480	85660-80007
A62L4	85660-80007	7		INDUCT P/S FLTR	28480	85660-80007
A62L5	85660-80007	7		INDUCT P/S FLTR	28480	85660-80007
A62L6	85660-80007	7		INDUCT P/S FLTR	28480	85660-80007
A62L7	85660-80007	7		INDUCT P/S FLTR	28480	85660-80007
A62L8	85660-80007	7		INDUCT P/S FLTR	28480	85660-80007
A62MP1	1251-2313	6	1	CONNECTOR-SGL CONT SKT .04-IN-BSC-SZ RND	28480	1251-2313
A62MP2	08340-20052	7	1	HEAT SINK	28480	08340-20052
A62MP3	1251-1115	4	20	POLARIZING KEY-PC EDGE CONN	28480	1251-1115
A62MP4	1251-5595	2	2	POLARIZING KEY-POST CONN (AL2J2)	28480	1251-5595
A62MP5	85660-00026	2	1	SHOCK MNT BOTTOM	28480	85660-00026
A62MP6	1520-0205	2	2	SHOCK MOUNT .47-EFF-HGT	28480	1520-0205
A62MP7	2200-0105	4	1	SCREW-MACH 4-40 .312-IN-LG PAN-HD-POZI	00000	ORDER BY DESCRIPTION
A62MP8				NOT ASSIGNED		
A62MP9				NOT ASSIGNED		
A62MP10				NOT ASSIGNED		
A62MP11	0890-0048	3	1	TUBING-FLEX .02-ID TFE .01-WALL	00000	ORDER BY DESCRIPTION
A62P1	1251-0600	0	2	CONNECTOR-SGL CONT PIN 1.14-MM-BSC-SZ SQ	28480	1251-0600
A62P2	1251-0600	0		CONNECTOR-SGL CONT PIN 1.14-MM-BSC-SZ SQ	28480	1251-0600
A62Q1	1854-0618	8	2	TRANSISTOR NPN SI DARL TO-3 PD=150W	04713	MJ3000
A62Q2	1854-0294	6	1	TRANSISTOR NPN SI TO-3 PD=115W FT=500KHZ	28480	1854-0294
A62Q3	1854-0618	8		TRANSISTOR NPN SI DARL TO-3 PD=150W	04713	MJ3000
A62Q4	1854-0679	1	1	TRANSISTOR NPN 2N5685 SI TO-3 PD=200W	04713	2N5685

See introduction to this section for ordering information.

Indicates factory selected value.

Table 6-3. Replaceable Parts

Reference Designation	HP Part Number	C D	Qty	Description	Mfr Code	Mfr Part Number
A62R1	0757-1094	9	1	RESISTOR 1.47K 1% .125W F TC=0+-100	24546	C4-1/B-T0-1471-F
A62R2	0757-0836	5	1	RESISTOR 7.5K 1% .5W F TC=0+-100	2B480	0757-0836
A62R3	0698-3404	3	1	RESISTOR 383 1% .5W F TC=0+-100	2B480	0698-3404
A62R4	0757-0436	1	1	RESISTOR 4.32K 1% .125W F TC=0+-100	24546	C4-1/B-T0-4321-F
A62R5, 6				NOT ASSIGNED		
A62R7	0698-7229	8	7	RESISTOR 511 1% .05W F TC=0+-100	24546	C3-1/B-T0-511R-F
A62R8	0698-7229	8		RESISTOR 511 1% .05W F TC=0+-100	24546	C3-1/B-T0-511R-F
A62R9	0698-7229	8		RESISTOR 511 1% .05W F TC=0+-100	24546	C3-1/B-T0-511R-F
A62R10	0698-7229	8		RESISTOR 511 1% .05W F TC=0+-100	24546	C3-1/B-T0-511R-F
A62R11	0698-7229	8		RESISTOR 511 1% .05W F TC=0+-100	24546	C3-1/B-T0-511R-F
A62R12	0698-7229	8		RESISTOR 511 1% .05W F TC=0+-100	24546	C3-1/B-T0-511R-F
A62R13	0698-7229	8		RESISTOR 511 1% .05W F TC=0+-100	24546	C3-1/B-T0-511R-F
A62U1	1826-0423	4	1	IC V RGLTR TO-3	27014	LM317K
A62W1	0B340-60057	6	1	CBL RBN 50 PN	2B480	0B340-60057
A62XA19	1251-1626	2	1	CONNECTOR-PC EDGE 12-CONT/ROW 2-ROWS	2B480	1251-1626
A62XA21	1251-2134	9	3	CONNECTOR-PC EDGE 18-CONT/ROW 2-ROWS	2B480	1251-2134
A62XA24	1251-2134	9		CONNECTOR-PC EDGE 18-CONT/ROW 2-ROWS	2B480	1251-2134
A62XA25	1251-1887	7	3	CONNECTOR-PC EDGE 22-CONT/ROW 2-ROWS	2B480	1251-1887
A62XA26	1251-1887	7		CONNECTOR-PC EDGE 22-CONT/ROW 2-ROWS	2B480	1251-1887
A62XA27	1251-7187	2	1	CONNECTOR-PC EDGE 31-CONT/ROW 2-ROWS	2B480	1251-7187
A62XA28	1251-1887	7		CONNECTOR-PC EDGE 22-CONT/ROW 2-ROWS	2B480	1251-1887
A62XA35	1251-2026	8	5	CONNECTOR-PC EDGE 18-CONT/ROW 2-ROWS	2B480	1251-2026
A62XA36	1251-2035	9	6	CONNECTOR-PC EDGE 15-CONT/ROW 2-ROWS	2B480	1251-2035
A62XA37	1251-2026	8		CONNECTOR-PC EDGE 18-CONT/ROW 2-ROWS	2B480	1251-2026
A62XA38	1251-2035	9		CONNECTOR-PC EDGE 15-CONT/ROW 2-ROWS	2B480	1251-2035
A62XA39	1251-2035	9		CONNECTOR-PC EDGE 15-CONT/ROW 2-ROWS	2B480	1251-2035
A62XA40	1251-2035	9		CONNECTOR-PC EDGE 15-CONT/ROW 2-ROWS	2B480	1251-2035
A62XA41	1251-2035	9		CONNECTOR-PC EDGE 15-CONT/ROW 2-ROWS	2B480	1251-2035
A62XA42	1251-2026	8		CONNECTOR-PC EDGE 18-CONT/ROW 2-ROWS	2B480	1251-2026
A62XA43	1251-2026	8		CONNECTOR-PC EDGE 18-CONT/ROW 2-ROWS	2B480	1251-2026
A62XA52	1251-2582	1	1	CONNECTOR-PC EDGE 24-CONT/ROW 2-ROWS	2B480	1251-2582
A62XA53	1251-2134	9		CONNECTOR-PC EDGE 18-CONT/ROW 2-ROWS	2B480	1251-2134
A62XA54	1251-2026	8		CONNECTOR-PC EDGE 18-CONT/ROW 2-ROWS	2B480	1251-2026
A62XA55	1251-1886	6	1	CONNECTOR-PC EDGE 15-CONT/ROW 2-ROWS	2B480	1251-1886
A62XA56	1251-2035	9		CONNECTOR-PC EDGE 15-CONT/ROW 2-ROWS	2B480	1251-2035
A62XA57	1251-7472	8	5	CONNECTOR - POST TYPE	2B480	1251-7472
A62XA58	1251-7472	8		CONNECTOR - POST TYPE	2B480	1251-7472
A62XA59	1251-7472	8		CONNECTOR - POST TYPE	2B480	1251-7472
A62XA60	1251-7472	8		CONNECTOR - POST TYPE	2B480	1251-7472
A62XA61	1251-7472	8		CONNECTOR - POST TYPE	2B480	1251-7472

See Introduction to this section for ordering information.

*Indicates factory selected value.

Table 6-3. Replaceable Parts

Reference Designation	HP Part Number	C D	Qty	Description	Mfr Code	Mfr Part Number
A63	08340-60175	9	1	90 DB PROGRAMMABLE ATTENUATOR	28480	08340-60175
				MISCELLANEOUS ELECTRICAL PARTS		
AT1	0960-0638	8	1	PERIPHERAL MODE ISOLATOR	28480	0960-0638
AT2	0955-0090	3	1	ATTENUATOR 15 DB	28480	0955-0090
B1	08340-60055	4	1	FAN ASSEMBLY (STANDARD) (INCL B1W1) 08340-60055 INCLUDES THE FOLLOWING PARTS:	28480	08340-60055
	0360-0535	0	2	TERMINAL TEST POINT PCB	00000	ORDER BY DESCRIPTION
	0890-0029	0	1	TUBING-HS .187-D/.093-RCVD .02-WALL	28480	0890-0029
	0890-0983	5	1	TUBING-HS .125-D/.062-RCVD .02-WALL	28480	0890-0983
	1251-4223	1	2	CONNECTOR- CONT F .025	28480	1251-4223
	1251-6796	7	1	CONNECTOR HOUSING- 3 FEMALE IR	28480	1251-6796
	1400-0249	0	1	CABLE TIE .062-.625-DIA .091-WD NYL	06383	PLT1M-8
	1520-0230	3	4		28480	1520-0230
	2190-0017	4	2	WASHER-LK HLCL NO. 8 .168-IN-ID	28480	2190-0017
	2200-0770	9	10	SCREW-MACH 4-40 .188-IN-LG 100 DEG	00000	ORDER BY DESCRIPTION
	2360-0119	8	4	SCREW-MACH 6-32 .438-IN-LG PAN-HD-POZI	00000	ORDER BY DESCRIPTION
	2360-0196	1	4	SCREW-MACH 6-32 .375-IN-LG 100 DEG	00000	ORDER BY DESCRIPTION
	2510-0135	7	2	SCREW-MACH 8-32 2.25-IN-LG PAN-HD-POZI	00000	ORDER BY DESCRIPTION
	2680-0137	8	1	SCREW-MACH 10-32 .188-IN-LG PAN-HD-SLT	00000	ORDER BY DESCRIPTION
	3160-0371	1	1	FAN-TBAX 180-CFM 115V 50/60-HZ	28480	3160-0371
	8150-0011	0	1	WIRE 22AWG G 300V PVC 7X30 105C	28480	8150-0011
	8150-0447	6	1	WIRE 24AWG BK 300V PVC 7X32 80C	28480	8150-0447
	08340-00012	7	1	HOUSING FAN (TOP)	28480	08340-00012
	08340-00013	8	1	HOUSING FAN (BOTTOM)	28480	08340-00013
	08340-00014	9	1	HOUSING FAN (GRILLE)	28480	08340-00014
	08340-00016	1	1	BASE PLATE	28480	08340-00016
	08340-00017	2	1	GRILL AIR FILTER	28480	08340-00017
	08340-00018	3	1	FILTER-AIR	28480	08340-00018
	85660-20092	4	4	SNUBBER-SHOCK MOUNT	28480	85660-20092
C1	0160-4065	5	1	CAPACITOR-FXD .1UF +-20% 250VAC(RMS)	28480	0160-4065
C2	0160-4819	7	1	CAPACITOR-FXD 2200PF +-5% 100VDC CER	28480	0160-4819
C3	0160-4832	4	1	CAPACITOR-FXD .01UF +-10% 100VDC CER	28480	0160-4832
C4	0160-4063	3	1	CAPACITOR-FXD 0.39 UF 21.0 VDC	28480	0160-4063
CR1	1901-0179	7	2	DIODE-SWITCHING 15V 50MA 750PS DO-7	28480	1901-0179
CR2	1901-0179	7	2	DIODE-SWITCHING 15V 50MA 750PS DO-7	28480	1901-0179
DS1	1990-0858	6	1	LED-LAMP LUM-INT=150UCD IF=25MA MAX	28480	1990-0858
	1450-0615	9	1	LAMPHOLDER	28480	1450-0615
	08340-40002	9	1	L.E.D. MOUNT	28480	08340-40002
F1	2110-0002	9	1	FUSE 2A 250V NTD 1.25X.25 UL (REQUIRED FOR 240V OPERATION)	75915	312002
F1	2110-0003	0	1	FUSE 3A 250V NTD 1.25X.25 UL (REQUIRED FOR 200V OPERATION)	75915	312003
F1	2110-0010	9	1	FUSE 5A 250V NTD 1.25X.25 UL (REQUIRED FOR 100V OPERATION)	75915	312005
F1	2110-0055	2	1	FUSE 4A 250V NTD 1.25X.25 UL (REQUIRED FOR 120V OPERATION)	75915	312004
FL1	0960-0443	1	1	LINE MODULE-FILTERED	28480	0960-0443
J1				SEE J1W1		
J1W1	08340-60071	4	1	CABLE ASSY-COAX (SWP OUT)	28480	08340-60071
	0590-1251	6	4	NUT-SPCLY 15/32-32-THD .1-IN-THK .562-WD	00000	ORDER BY DESCRIPTION
	1250-0870	4	3	CONNECTOR-RF BNC FEM SGL-HOLE-RR 50-OHM	28480	1250-0870
J2				SEE J2W1		
J2W1	08340-60066	7	1	CABLE ASSY-COAX (PULSE)	28480	08340-60066
	0590-1251	6	4	NUT-SPCLY 15/32-32-THD .1-IN-THK .562-WD	00000	ORDER BY DESCRIPTION
	1250-0870	4	4	CONNECTOR-RF BNC FEM SGL-HOLE-RR 50-OHM	28480	1250-0870
J3				SEE J3W1		
J3W1	08340-60069	0	1	CABLE ASSY-COAX (AM)	28480	08340-60069
	0590-1251	6	4	NUT-SPCLY 15/32-32-THD .1-IN-THK .562-WD	00000	ORDER BY DESCRIPTION
	1250-0870	4	4	CONNECTOR-RF BNC FEM SGL-HOLE-RR 50-OHM	28480	1250-0870
J4				SEE J4W1		
J4W1	08340-60068	9	1	CABLE ASSY-COAX (EXT INPUT)	28480	08340-60068
	00310-48801	0	2	WASHER-SHOULDERED	28480	00310-48801
	0590-1251	6	1	NUT-SPCLY 15/32-32-THD .1-IN-THK .562-WD	00000	ORDER BY DESCRIPTION
	0360-1158	5	1	LUG	28480	0360-1158
	1250-1091	3	1	CONNECTOR-RF BNC FEM SGL-HOLE-RR 50-OHM	28480	1250-1091
J5	5061-5316	6	1	RF OUTPUT CONNECTOR ASSEMBLY	28480	5061-1100
	5061-5311	1	1	3.5 MM F/F ADAPTER	28480	5061-5311
	1250-1745	4	4	TYPE N(F) TO APC-3.5(F) ADAPTER	28480	1250-1745
J6	1250-0083	1	8	CONNECTOR-RF BNC FEM SGL-HOLE-FR 50-OHM	28480	1250-0083
	0360-1632	0	4	TERMINAL-SLDR LUG LK-MTG FOR-// 3/B-SCR	28480	0360-1632
	2950-0001	8	2	NUT-HEX-DBL-CHAM 3/8-32-THD .094-IN-THK	00000	ORDER BY DESCRIPTION
J7	1250-0083	1	8	CONNECTOR-RF BNC FEM SGL-HOLE-FR 50-OHM	28480	1250-0083
	0360-1632	0	4	TERMINAL-SLDR LUG LK-MTG FOR-// 3/B-SCR	28480	0360-1632
	2950-0001	8	2	NUT-HEX-DBL-CHAM 3/8-32-THD .094-IN-THK	00000	ORDER BY DESCRIPTION

See introduction to this section for ordering information.

* Indicates factory selected value.

Replaceable Parts

Table 6-3. Replaceable Parts

Reference Designation	HP Part Number	C D	Qty	Description	Mfr Code
J7W1	08340-60070	3	1	CABLE ASSY-COAX (A62J8 TO R.P. J7)	28-189
J8	1250-0102 2190-0068 2950-0054	5 5 1	3	CONNECTOR-RF BNC FEM SGL-HOLE-FR 50-OHM WASHER-LK INTL T 1/2 IN .505-IN-ID NUT-HEX-DBL-CHAM 1/2-28-THD .125-IN-THK	28-190 28-191 00-000
J8W1	08340-60086	1	1	CABLE ASSY-COAX (A29J5 TO R.P. J8)	28-189
J9	1250-0102 2190-0068 2950-0054	5 5 1		CONNECTOR-RF BNC FEM SGL-HOLE-FR 50-OHM WASHER-LK INTL T 1/2 IN .505-IN-ID NUT-HEX-DBL-CHAM 1/2-28-THD .125-IN-THK	28-190 28-191 00-000
J9W1	08340-60089	4	1	CABLE ASSY-COAX (A51J1 TO R.P. J9)	28-189
J10	1250-0102 2190-0068 2950-0054	5 5 1		CONNECTOR-RF BNC FEM SGL-HOLE-FR 50-OHM WASHER-LK INTL T 1/2 IN .505-IN-ID NUT-HEX-DBL-CHAM 1/2-28-THD .125-IN-THK	28-190 28-191 00-000
J10W1	08340-60085	0	1	CABLE ASSY-COAX (A29J1 TO R.P. J10)	28-189
J11	1250-0083 2190-0016	1 3	4	CONNECTOR-RF BNC FEM SGL-HOLE-FR 50-OHM WASHER-LK INTL T 3/8 IN .377-IN-ID	28-190 28-191
J12	1250-0083 2190-0016	1 3		CONNECTOR-RF BNC FEM SGL-HOLE-FR 50-OHM WASHER-LK INTL T 3/8 IN .377-IN-ID	28-190 28-191
J13	1250-0083 0360-1632	1 0		CONNECTOR-RF BNC FEM SGL-HOLE-FR 50-OHM TERMINAL-SLDR LUG LK-MTG FOR-#3/8-SCR	28-190 28-191
J14	1250-0083 2190-0016	1 3		CONNECTOR-RF BNC FEM SGL-HOLE-FR 50-OHM WASHER-LK INTL T 3/8 IN .377-IN-ID	28-190 28-191
J15	1250-0083 2190-0016	1 3		CONNECTOR-RF BNC FEM SGL-HOLE-FR 50-OHM WASHER-LK INTL T 3/8 IN .377-IN-ID	28-190 28-191
J16	1250-0083 0360-1632	1 0		CONNECTOR-RF BNC FEM SGL-HOLE-FR 50-OHM TERMINAL-SLDR LUG LK-MTG FOR-#3/8-SCR	28-190 28-191
J17	1251-6781	0	1	CONNECTOR 3-PIN M CIRC AUDIO (INCLUDES MOUNTING HARDWARE)	28-191
J18	1251-0064 1251-2942	0 7	1 2	CONNECTOR 25-PIN F D SERIES MOUNTING HARDWARE KIT	28-191 28-192
J19	08340-60127 2190-0104 2950-0132	1 0 6	1 1 1	CONNECTOR-TYPE N (R.P. AUX OUT) WASHER-LK INTL T 7/16 IN .439-IN-ID NUT-HEX-DBL-CHAM 7/16-28-THD .094-IN-THK	28-191 28-191 00-000
J20				(REFER TO OPTION 004 AND 005 LISTINGS)	
J21				SEE J21W1	
J21W1	8120-3653	9	1	CABLE ASSY-RIBBON (HP-IB) (INCLUDES J21 & MOUNTING HARDWARE)	28-489
RPG1	08340-60197	5	1	ROTARY PULSE GENERATOR REPLACEMENT KIT (INCLUDES LOCKING TANGS, CONNECTOR HOUSING, NUT AND WASHER)	28-489
S1	3101-2193	5	1	SWITCH-TGL SUBMIN SPDT 2A 250VAC	28-190
S2	3101-0163	5	1	FREQUENCY STANDARD SWITCH KIT (INCLUDES MOUNTING HARDWARE)	28-489
T1	9100-4133	1	1	TRANSFORMER	28-190
				NOTE	
				The complete transformer assembly (including the wiring harness and all attached lugs) may be ordered as 08340-60124 CD6. Individual lugs for the transformer wiring harness may be ordered separately as indicated below.	
	0360-0037	7	6	TRANSFORMER WIRE SOLDER LUGS; TERMINAL-SLDR LUG PL-MTG FOR-#16-SCR	28-191
	0360-0042	4	2	TERMINAL-SLDR LUG PL-MTG FOR-#16-SCR	28-190
	0360-0043	5	1	TERMINAL-SLDR LUG PL-MTG FOR-#16-SCR	28-190
W1	08340-60062	3	1	CABLE ASSY-RIBBON A7J1 TO A6J1	28-489
W2	NONE			WIRE ASSY-RF MODULE(GND) TO FRONT PANEL	
W3	08340-20198	2	1	CABLE ASSY-RIGID COAX W51 TO A16J2	28-489
W4	08340-20116	4	1	CABLE ASSY-RIGID COAX A16J1 TO J19	28-489
W5	08340-20104	0	1	CABLE ASSY-RIGID COAX A17J2 TO A16J7	28-489
W6	08340-20108	4	1	CABLE ASSY-RIGID COAX A16J6 TO A14J1	28-489
W7	08340-20110	8	1	CABLE ASSY-RIGID COAX A14J1 TO A11J1	28-489
W8	08340-20111	9	1	CABLE ASSY-RIGID COAX A11J2 TO A13J1	28-190
W9	08340-20114	2	1	CABLE ASSY-RIGID COAX A8A2J1 TO A9J1	28-190
W10	08340-20115	3	1	CABLE ASSY-RIGID COAX A9J2 TO A15J1	28-489
W11	08340-20109	5	1	CABLE ASSY-RIGID COAX A15J2 TO A17J1	28-190
W12	08340-20107	3	1	CABLE ASSY-RIGID COAX A17J3 TO A18J1	28-489
W13	08340-20223	4	1	CABLE ASSY-RIGID COAX A18J2 TO A12J1	28-489
W14	08340-20224	5	1	CABLE ASSY-RIGID COAX A12J2 TO A13J2	28-489
W15				NOT ASSIGNED	
W16	08340-20221	2	1	CABLE ASSY-RIGID COAX A13J3 TO A10J1	28-190
W17				NOT ASSIGNED	

See introduction to this section for ordering information.

*Indicates factory selected value.

Table 6-3. Replaceable Parts

Reference Designation	HP Part Number	C D	Qty	Description	Mfr Code	Mfr Part Number
A63	08340-60175	9	1	90 DB PROGRAMMABLE ATTENUATOR	28480	08340-60175
				MISCELLANEOUS ELECTRICAL PARTS		
AT1	0960-0638	8	1	PERIPHERAL MODE ISOLATOR	28480	0960-0638
AT2	0955-0090	3	1	ATTENUATOR 15 DB	28480	0955-0090
B1	08340-60055	4	1	FAN ASSEMBLY (STANDARD) (INCL B1W1) 08340-60055 INCLUDES THE FOLLOWING PARTS:	28480	08340-60055
	0360-0535	0	2	TERMINAL TEST POINT PCB	00000	ORDER BY DESCRIPTION
	0890-0029	0	1	TUBING-HS .187-DI.091-REV.D .02-WALL	28480	0890-0029
	0890-0983	5	1	TUBING-HS .125-DI.062-REV.D .02-WALL	28480	0890-0983
	1251-4223	1	2	CONNECTOR-COAXIAL .025	28480	1251-4223
	1251-6796	7	1	CONNECTOR HOUSING 31 FEMALE IIR	28480	1251-6796
	1400-0249	0	1	CABLE TIE .062-.625-DIA .091-WD NYL	06383	PLT1M-8
	1520-0230	3	4		28480	1520-0230
	2190-0017	4	2	WASHER-LK HLCL NO. 8 .168-IN-ID	28480	2190-0017
	2200-0770	9	10	SCREW-MACH 4-40 .188-IN-LG 100 DEG	00000	ORDER BY DESCRIPTION
	2360-0119	8	4	SCREW-MACH 6-32 .438-IN-LG PAN-HD POZI	00000	ORDER BY DESCRIPTION
	2360-0196	1	4	SCREW-MACH 6-32 .375-IN-LG 100 DEG	00000	ORDER BY DESCRIPTION
	2510-0135	7	2	SCREW-MACH 8-32 2.25-IN-LG PAN-HD-POZI	00000	ORDER BY DESCRIPTION
	2680-0137	8	1	SCREW-MACH 10-32 .188-IN-LG PAN-HD-SLT	00000	ORDER BY DESCRIPTION
	3160-0371	1	1	FAN-TBAX 180-CFM 115V 50/60-HZ	28480	3160-0371
	8150-0011	0	1	WIRE 22AWG G 300V PVC 7X30 105C	28480	8150-0011
	8150-0447	6	1	WIRE 24AWG BK 300V PVC 7X32 80C	28480	8150-0447
	08340-00012	7	1	HOUSING FAN (TOP)	28480	08340-00012
	08340-00013	8	1	HOUSING FAN (BOTTOM)	28480	08340-00013
	08340-00014	9	1	HOUSING FAN (GRILLE)	28480	08340-00014
	08340-00016	1	1	BASE PLATE	28480	08340-00016
	08340-00017	2	1	GRILL AIR FILTER	28480	08340-00017
	08340-00018	3	1	FILTER-AIR	28480	08340-00018
	85660-20092	4	4	SNUBBER-SHOCK MOUNT	28480	85660-20092
C1	0160-4065	5	1	CAPACITOR-FXD .1UF +-20% 250VAC(RMS)	28480	0160-4065
C2	0160-4819	7	1	CAPACITOR-FXD 2200PF +-5% 100VDC CER	28480	0160-4819
C3	0160-4832	4	1	CAPACITOR-FXD .01UF +-10% 100VDC CER	28480	0160-4832
C4	0160-4063	3	1	CAPACITOR-FXD 0.39 UF 21.0 VDC	28480	0160-4063
CR1	1901-0179	7	2	DIODE-SWITCHING 15V 50MA 750PS DO-7	28480	1901-0179
CR2	1901-0179	7	2	DIODE-SWITCHING 15V 50MA 750PS DO-7	28480	1901-0179
DS1	1990-0858	6	1	LED-LAMP LUM-INT=150UCD IF=25MA MAX	28480	1990-0858
	1450-0615	9	1	LAMPHOLDER	28480	1450-0615
	08340-40002	9	1	L.E.D. MOUNT	28480	08340-40002
F1	2110-0002	9	1	FUSE 2A 250V NTD 1.25X.25 UL (REQUIRED FOR 240V OPERATION)	75915	312002
F1	2110-0003	0	1	FUSE 3A 250V NTD 1.25X.25 UL (REQUIRED FOR 200V OPERATION)	75915	312003
F1	2110-0010	9	1	FUSE 5A 250V NTD 1.25X.25 UL (REQUIRED FOR 100V OPERATION)	75915	312005
F1	2110-0055	2	1	FUSE 4A 250V NTD 1.25X.25 UL (REQUIRED FOR 120V OPERATION)	75915	312004
FL1	08340-60257	8	1	LINE MODULE-FILTERED, REPLACEMENT KIT (INCLUDES 2 METAL RETAINERS)	28480	08340-60257
J1/J1W1	08340-60071	4	1	CABLE ASSY-COAX (SWP OUT)	28480	08340-60071
	0590-1251	6	4	NUT-SPCLY 15/32-32-THD .1-IN-THK .562-WD	00000	ORDER BY DESCRIPTION
	1250-0870	4	3	CONNECTOR-RF BNC FEM SGL-HOLE-RR 50-OHM	28480	1250-0870
J2				SEE J2W1		
J2W1	08340-60066	7	1	CABLE ASSY-COAX (PULSE)	28480	08340-60066
	0590-1251	6		NUT-SPCLY 15/32-32-THD .1-IN-THK .562-WD	00000	ORDER BY DESCRIPTION
	1250-0870	4		CONNECTOR-RF BNC FEM SGL-HOLE-RR 50-OHM	28480	1250-0870
J3				SEE J3W1		
J3W1	08340-60069	0	1	CABLE ASSY-COAX (AM)	28480	08340-60069
	0590-1251	6		NUT-SPCLY 15/32-32-THD .1-IN-THK .562-WD	00000	ORDER BY DESCRIPTION
	1250-0870	4		CONNECTOR-RF BNC FEM SGL-HOLE-RR 50-OHM	28480	1250-0870
J4				SEE J4W1		
J4W1	08340-60068	9	1	CABLE ASSY-COAX (EXT INPUT)	28480	08340-60068
	00310-48801	0	2	WASHER-SHOULDERED	28480	00310-48801
	0590-1251	6	1	NUT-SPCLY 15/32-32-THD .1-IN-THK .562-WD	00000	ORDER BY DESCRIPTION
	0360-1158	5	1	LUG	28480	0360-1158
	1250-1091	3	1	CONNECTOR-RF BNC FEM SGL-HOLE-RR 50-OHM	28480	1250-1091
J5	5061-5316	6	1	RF OUTPUT CONNECTOR ASSEMBLY	28480	5061-1100
	5061-5311	1	1	3.5 MM F/F ADAPTER	28480	5061-5311
	1250-1745	4		TYPE N(F) TO APC-3.5(F) ADAPTER	28480	1250-1745
J6	1250-0083	1	8	CONNECTOR-RF BNC FEM SGL-HOLE-FR 50-OHM	28480	1250-0083
	0360-1632	0	4	TERMINAL-SLDR LUG LK-MTG FOR-# 3/8-SCR	28480	0360-1632
	2950-0001	8	2	NUT-HEX-DBL-CHAM 3/8-32-THD .094-IN-THK	00000	ORDER BY DESCRIPTION
J7	1250-0083	1	0	CONNECTOR-RF BNC FEM SGL-HOLE-FR 50-OHM	28480	1250-0083
	0360-1632	0	1	TERMINAL-SLDR LUG LK-MTG FOR-# 3/8-SCR	28480	0360-1632
	2950-0001	8	1	NUT-HEX-DBL-CHAM 3/8-32-THD .094-IN-THK	00000	ORDER BY DESCRIPTION

See introduction to this section for ordering information.

*Indicates factory selected value.

Table 6-3. Replaceable Parts

Reference Designation	HP Part Number	C D	Qty	Description	Mfr Code	Mfr Part Number
J7W1	08340-60070	3	1	CABLE ASSY-COAX (A62J8 TO R.P. J7)	28480	08340-60070
J8	1250-0102	5	3	CONNECTOR-RF BNC FEM SGL-HOLE-FR 50-OHM	28480	1250-0102
	2190-0068	5	3	WASHER-LK INTL T 1/2 IN .505-IN-ID	28480	2190-0068
	2950-0054	1	3	NUT-HEX-DBL-CHAM 1/2-28-THD .125-IN-THK	00000	ORDER BY DESCRIPTION
J8W1	08340-60086	1	1	CABLE ASSY-COAX (A29J5 TO R.P. J8)	28480	08340-60086
J9	1250-0102	5	5	CONNECTOR-RF BNC FEM SGL-HOLE-FR 50-OHM	28480	1250-0102
	2190-0068	5	5	WASHER-LK INTL T 1/2 IN .505-IN-ID	28480	2190-0068
	2950-0054	1	5	NUT-HEX-DBL-CHAM 1/2-28-THD .125-IN-THK	00000	ORDER BY DESCRIPTION
J9W1	08340-60089	4	1	CABLE ASSY-COAX (A51J1 TO R.P. J9)	28480	08340-60089
J10	1250-0102	5	5	CONNECTOR-RF BNC FEM SGL-HOLE-FR 50-OHM	28480	1250-0102
	2190-0068	5	5	WASHER-LK INTL T 1/2 IN .505-IN-ID	28480	2190-0068
	2950-0054	1	5	NUT-HEX-DBL-CHAM 1/2-28-THD .125-IN-THK	00000	ORDER BY DESCRIPTION
J10W1	08340-60085	0	1	CABLE ASSY-COAX (A29J1 TO R.P. J10)	28480	08340-60085
J11	1250-0083	1	3	CONNECTOR-RF BNC FEM SGL-HOLE-FR 50-OHM	28480	1250-0083
	2190-0016	3	4	WASHER-LK INTL T 3/8 IN .377-IN-ID	28480	2190-0016
J12	1250-0083	1	3	CONNECTOR-RF BNC FEM SGL-HOLE-FR 50-OHM	28480	1250-0083
	2190-0016	3	3	WASHER-LK INTL T 3/8 IN .377-IN-ID	28480	2190-0016
J13	1250-0083	1	0	CONNECTOR-RF BNC FEM SGL-HOLE-FR 50-OHM	28480	1250-0083
	0360-1632	0	1	TERMINAL-SLDR LUG LK-MTG FOR-#3/8-SCR	28480	0360-1632
J14	1250-0083	1	3	CONNECTOR-RF BNC FEM SGL-HOLE-FR 50-OHM	28480	1250-0083
	2190-0016	3	3	WASHER-LK INTL T 3/8 IN .377-IN-ID	28480	2190-0016
J15	1250-0083	1	3	CONNECTOR-RF BNC FEM SGL-HOLE-FR 50-OHM	28480	1250-0083
	2190-0016	3	3	WASHER-LK INTL T 3/8 IN .377-IN-ID	28480	2190-0016
J16	1250-0083	1	0	CONNECTOR-RF BNC FEM SGL-HOLE-FR 50-OHM	28480	1250-0083
	0360-1632	0	1	TERMINAL-SLDR LUG LK-MTG FOR-#3/8-SCR	28480	0360-1632
J17	1251-6781	0	1	CONNECTOR 3-PIN M CIRC AUDIO (INCLUDES MOUNTING HARDWARE)	28480	1251-6781
J18	1251-0064	0	1	CONNECTOR 25-PIN F D SERIES	28480	1251-0064
	1251-2942	7	2	MOUNTING HARDWARE KIT	28480	1251-2942
J19	08340-60127	1	1	CONNECTOR-TYPE N (R.P. AUX OUT)	28480	08340-60127
	2190-0104	0	1	WASHER-LK INTL T 7/16 IN .439-IN-ID	28480	2190-0104
	2950-0132	6	1	NUT-HEX-DBL-CHAM 7/16-28-THD .094-IN-THK	00000	ORDER BY DESCRIPTION
J20				(REFER TO OPTION 004 AND 005 LISTINGS)		
J21				SEE J21W1		
J21W1	8120-3653	9	1	CABLE ASSY-RIBBON (HP-IB) (INCLUDES J21 & MOUNTING HARDWARE)	28480	8120-3653
RPG1	08340-60197	5	1	ROTARY PULSE GENERATOR REPLACEMENT KIT (INCLUDES LOCKING TANGS, CONNECTOR HOUSING, NUT AND WASHER)	28480	08340-60197
S1	3101-2193	5	1	SWITCH-TGL SUBMIN SPDT 2A 250VAC	28480	3101-2193
S2	3101-0163	5	1	FREQUENCY STANDARD SWITCH KIT (INCLUDES MOUNTING HARDWARE)	28480	3101-0163
T1	9100-4133	1	1	TRANSFORMER	28480	9100-4133
				NOTE		
				The complete transformer assembly (including the wiring harness and all attached lugs) may be ordered as 08340-60124 CDB. Individual lugs for the transformer wiring harness may be ordered separately as indicated below.		
	0360-0037	7	6	TRANSFORMER WIRE SOLDER LUGS: TERMINAL-SLDR LUG PL-MTG FOR-#6-SCR	28480	0360-0037
	0360-0042	4	2	TERMINAL-SLDR LUG PL-MTG FOR-#6-SCR	28480	0360-0042
	0360-0043	5	1	TERMINAL-SLDR LUG PL-MTG FOR-#6-SCR	28480	0360-0043
W1	08340-60062	3	1	CABLE ASSY-RIBBON A7J1 TO A6J1	28480	08340-60062
W2	NONE		1	WIRE ASSY-RF MODULE(GND) TO FRONT PANEL		
W3	08340-20198	2	1	CABLE ASSY-RIGID COAX W51 TO A16J2	28480	08340-20198
W4	08340-20116	4	1	CABLE ASSY-RIGID COAX A16J1 TO J19	28480	08340-20116
W5	08340-20104	0	1	CABLE ASSY-RIGID COAX A17J2 TO A16J7	28480	08340-20104
W6	08340-20108	4	1	CABLE ASSY-RIGID COAX A16J6 TO A14J1	28480	08340-20108
W7	08340-20110	8	1	CABLE ASSY-RIGID COAX A14J1 TO A1J1	28480	08340-20110
W8	08340-20111	9	1	CABLE ASSY-RIGID COAX A1J2 TO A13J1	28480	08340-20111
W9	08340-20114	2	1	CABLE ASSY-RIGID COAX A8A2J1 TO A9J1	28480	08340-20114
W10	08340-20115	3	1	CABLE ASSY-RIGID COAX A9J2 TO A15J1	28480	08340-20115
W11	08340-20109	5	1	CABLE ASSY-RIGID COAX A15J2 TO A17J1	28480	08340-20109
W12	08340-20107	3	1	CABLE ASSY-RIGID COAX A17J3 TO A18J1	28480	08340-20107
W13	08340-20223	4	1	CABLE ASSY-RIGID COAX A18J2 TO A12J1	28480	08340-20223
W14	08340-20224	5	1	CABLE ASSY-RIGID COAX A12J2 TO A13J2	28480	08340-20224
W15				NOT ASSIGNED		
W16	08340-20221	2	1	CABLE ASSY-RIGID COAX A13J3 TO A10J1	28480	08340-20221
W17				NOT ASSIGNED		

See Introduction to this section for ordering information.

*Indicates factory selected value.

Table 6-3. Replaceable Parts

Reference Designation	HP Part Number	C D	Qty	Description	Mfr Code	Mfr Part Number
W18	08340-20119	7	1	CABLE ASSY-RIGID COAX A10J3 TO A63J1(STD)	28480	08340-20119
W19	08340-20117	5	1	CABLE ASSY-RIGID COAX A63J2 TO J5 (STD.)	28480	08340-20117
W20	08340-20122	2	1	CABLE ASSY-RIGID COAX A63J2 TO J20 (004)	28480	08340-20122
W21	08340-20121	1	1	CABLE ASSY-RIGID COAX A10J3 TO J5 (001)	28480	08340-20121
W22	08340-20120	0	1	CABLE ASSY-RIGID COAX A10J3 TO J20 (005)	28480	08340-20120
W23	08340-60118	0	1	CABLE ASSY-COAX A30J3 TO A8A1J1	28480	08340-60118
W24	08340-60117	9	1	CABLE ASSY-COAX A62J14 TO A8A1J2	28480	08340-60117
W25	08340-60119	1	1	CABLE ASSY-COAX A62J10 TO A9J3	28480	08340-60119
W26	08340-60115	7	1	CABLE ASSY-COAX A12J3 TO A25J2	28480	08340-60115
W27	08340-60114	6	1	CABLE ASSY-COAX A11J2 TO A25J1	28480	08340-60114
W28	08340-60126	0	1	CABLE ASSY-COAX A62J13 TO A16J3	28480	08340-60126
W29	08340-60125	9	1	CABLE ASSY-COAX A62J25 TO A16J4	28480	08340-60125
W30	08340-60080	5	1	CABLE ASSY-COAX A16A1J2 TO A16J5	28480	08340-60080
W31	08340-60060	1	1	CABLE ASSY-RIBBON A62J19 TO A20J1/A16A1	28480	08340-60060
W32	08340-60058	7	1	CABLE ASSY-RIBBON A20J2 TO A14A1J1	28480	08340-60058
W33	08340-60061	2	1	CABLE ASSY-RIBBON A62J18 TO A13A1J1	28480	08340-60061
W34	08340-60116	8	1	CABLE ASSY-COAX A29J4 TO A37J1	28480	08340-60116
W35	08340-60081	6	1	CABLE ASSY-COAX A39J2 TO A30J2	28480	08340-60081
W36	08340-60073	6	1	CABLE ASSY-COAX A29J3 TO A42J1	28480	08340-60073
W37	08340-60075	8	1	CABLE ASSY-COAX A49J1 TO A44J1	28480	08340-60075
W38	08340-60074	7	1	CABLE ASSY-COAX A49J2 TO A62J6	28480	08340-60074
W39	08340-60078	1	1	CABLE ASSY-COAX A36J1 TO A49J3	28480	08340-60078
W40	08340-60072	5	1	CABLE ASSY-COAX A48J1 TO A49J4	28480	08340-60072
W41	08340-60084	9	1	CABLE ASSY-COAX A33J2 TO A48J2	28480	08340-60084
W42	08340-20197	1	1	CABLE ASSY-RIGID COAX A44J2 TO A45J1	28480	08340-20197
W43	08340-20196	0	1	CABLE ASSY-RIGID COAX AT2J2 TO A46J1	28480	08340-20196
W44	08340-20101	7	1	CABLE ASSY-RIGID COAX A46J2 TO A48U1J1	28480	08340-20101
W45	NONE		1	WIRE ASSY-STAR GND TO LUG BY A62J9		
W46	08340-60184	0	1	WIRE ASSY (ALSO INCLUDES W47 AND J7W1)	28480	08340-60184
W47	08340-60082	7	1	CABLE ASSY-COAX A62J27 TO A62J4	28480	08340-60082
W48	08340-60079	2	1	CABLE ASSY-COAX A62J5 TO A62J11	28480	08340-60079
W49	08340-60088	3	1	CABLE ASSY-COAX J8 TO J10	28480	08340-60088
W50	08340-60065	6	1	WIRE ASSY- A6J4 TO POWER SWITCH	28480	08340-60065
W51	08340-20195	9	1	CABLE ASSY-RIGID COAX A45J3 TO W3	28480	08340-20195

See introduction to this section for ordering information.

*Indicates factory selected value.

Table 6-3. Replaceable Parts

Reference Designation	HP Part Number	C D	Qty	Description	Mfr Code	Mfr Part Number
				OPTION CONFIGURATIONS		
				OPTION 001: FRONT PANEL RF OUTPUT-NO ATTENUATOR		
A63	08340-00028	5	1	DELETE THE FOLLOWING:	28480	08340-00028
W18	08340-60175	9	1	ATTENUATOR MOUNTING PLATE	28480	08340-60175
W19	08340-20119	7	1	90 DB PROGRAMMABLE ATTENUATOR	28480	08340-20119
	08340-20117	5	1	CABLE ASSY-RIGID COAX A10J3 TO A63J1	28480	08340-20117
				CABLE ASSY-RIGID COAX A63J2 TO J5	28480	
				ADD THE FOLLOWING:		
				CABLE ASSY-RIGID COAX A10J3 TO J5		
				OPTION 004: REAR PANEL RF OUTPUT WITH ATTENUATOR		
				DELETE THE FOLLOWING:		
W19	08340-20076	5	1	RF CONNECTOR BRACKET	28480	08340-20076
	08340-20117	5	1	CABLE ASSY-RIGID COAX A63J2 TO J5	28480	08340-20117
	08340-20078	7	1	BEZEL-KEYBOARD FINISH	28480	08340-20078
				ADD THE FOLLOWING:		
W20	08340-20122	2	1	CABLE ASSY-RIGID COAX A63J2 TO J20	28480	08340-20122
	83592-20063	2	1	PLUG BUTTON-FRONT PANEL	28480	83592-20063
	83595-20004	4	1	FRONT PANEL CONNECTOR SPACER	28480	83595-20004
	08340-20080	1	1	BEZEL-KEYBOARD FINISH	28480	08340-20080
	1400-0053	4	1	CLAMP-CABLE .172-DIA .375-WD NYL		
	2200-0145	2	1	SCREW-MACH 4-40 .438-IN-LG PAN-HD-POZI		
	2190-0019	6	1	WASHER-LK HLCL NO. 4 .115-IN-ID		
	3050-0105	6	1	WASHER-FL MTLCL NO. 4 .125-IN-ID		
				OPTION 005: REAR PANEL RF OUTPUT-NO ATTENUATOR		
				DELETE THE FOLLOWING:		
W18	08340-00028	5	1	ATTENUATOR MOUNTING PLATE	28480	08340-00028
W19	08340-20076	5	1	RF CONNECTOR BRACKET	28480	08340-20076
A63	08340-20119	7	1	CABLE ASSY-RIGID COAX A10J3 TO A63J1	28480	08340-20119
	08340-20117	5	1	CABLE ASSY-RIGID COAX A63J2 TO J5	28480	08340-20117
	08340-60175	9	1	90 DB PROGRAMMABLE ATTENUATOR	28480	08340-60175
	08340-20078	7	1	BEZEL-KEYBOARD FINISH	28480	08340-20078
				ADD THE FOLLOWING:		
W22	08340-20120	0	1	CABLE ASSY-RIGID COAX	28480	08340-20120
	83595-20004	4	1	FRONT PANEL CONNECTOR SPACER	28480	83595-20004
	83592-20063	2	1	PLUG BUTTON-FRONT PANEL	28480	83592-20063
	08340-20080	1	1	BEZEL-KEYBOARD FINISH	28480	08340-20080
	1400-0053	4	1	CLAMP-CABLE .172-DIA .375-WD NYL		
	2200-0145	2	1	SCREW-MACH 4-40 .438-IN-LG PAN-HD-POZI		
	2190-0019	6	1	WASHER-LK HLCL NO. 4 .115-IN-ID		
	3050-0105	6	1	WASHER-FL MTLCL NO. 4 .125-IN-ID		
				OPTION 006: DELETE PULSE MODULATION		
A21 (STD)	08340-60160	2	1	DELETE THE FOLLOWING: PULSE MODULATOR DRIVER (STD)	28480	08340-60160
A21 (OPT 006)	08341-60002	2	1	ADD THE FOLLOWING: PULSE MODULATION DRIVER (OPTION 006)	28480	08341-60002
				OPTION 806: CHASSIS SLIDE KIT		
				DELETE THE FOLLOWING:		
	5061-9517	7	1	CHASSIS COVER (SIDE) PERFORATED	28480	5061-9517
	5061-9462	1	1	CHASSIS COVER (SIDE)	28480	5061-9462
				ADD THE FOLLOWING:		
	08340-60136	2	1	SLIDE RACK MOUNT KIT	28480	08340-60136
				OPTION 850: INTERFACE CABLE FOR OPERATION WITH HP 8410B/C		
				ADD THE FOLLOWING:		
	08410-60146	9	1	INTERCONNECT CABLE	28480	08410-60146
				OPTION 908: RACK FLANGES WITHOUT HANDLES		
				ADD THE FOLLOWING:		
	5061-9678	1	1	RACK FLANGES WITHOUT HANDLES KIT	28480	5061-9678
				OPTION 913: RACK FLANGES WITH HANDLES		
				ADD THE FOLLOWING:		
	5061-9772	6	1	RACK FLANGES WITH HANDLES KIT	28480	5061-9772

See Introduction to this section for ordering information.

*Indicates factory selected value.

Table 6-3. Model 8340A Replaceable Parts

Reference Designation	HP Part Number	C D	Qty	Description	Mfr Code	Mfr Part Number
	5061-2072	5	1	OPTION 913: RACK FLANGES WITH HANDLES ADD THE FOLLOWING: RACK FLANGES WITH HANDLES KIT	28480	5061-2072

See introduction to this section for ordering information
 *Indicates factory selected value

Reference Designation	HP Part Number	C D	Qty	Description	Mfr Code	Mfr Part Number
MISCELLANEOUS MECHANICAL & CHASSIS PARTS						
1	0340-0923	B	10	INSULATOR-BSHG NYLON	28480	0340-0923
2	0360-0037	7	10	TERMINAL-SLDR LUG PL-MTG FOR-#6-SCR	28480	0360-0037
3	0360-0042	4	3	TERMINAL-SLDR LUG PL-MTG FOR-#6-SCR	28480	0360-0042
4	0400-0082	B	2	GROMMET-CHAN NCH .09-IN-GRV-WD	28480	0400-0082
5	0400-0219	3	3	GROMMET-RND .5-IN-ID .093-IN-GRV-WD	28480	0400-0219
6	0520-0127	6	4	SCREW-MACH 2-56 .188-IN-LG PAN-HD-POZI	00000	ORDER BY DESCRIPTION
7	0570-0632	3	10	SCREW-SPCL 4-40 .312-IN-LG PAN-HD-POZI	00000	ORDER BY DESCRIPTION
8	0580-1251	6	4	NUT-HEX 15/32-32	00000	ORDER BY DESCRIPTION
9	1200-0043	B	5	INSULATOR-XSTR ALUMINUM	28480	1200-0043
10	1400-0031	B	3	CLAMP-CABLE .375-DIA .5-WD NYL	28480	1400-0031
11	1400-0249	0	9	CABLE TIE .062-.625-DIA .091-WD NYL	06383	PLTIM-B
12	1400-0510	B	4	CLAMP-CABLE .15-DIA .62-WD NYL	28480	1400-0510
13	1400-0907	7	2	CLAMP-CABLE .187-DIA .5-WD FRD-NYLON	95987	3/16-HFR
14	1520-0205	2	3	SHOCK MOUNT .31 HGT.	28480	1520-0205
15	2190-0003	B	14	WASHER-LK HLCL NO. 4 .115-IN-ID	28480	2190-0003
16	2190-0006	1	15	WASHER-LK HLCL NO. 6 .141-IN-ID	28480	2190-0006
17	2190-0008	3	1	WASHER-LK EXT T NO. 6 .141-IN-ID	28480	2190-0008
18	2190-0011	B	6	WASHER-LK INTL T NO. 10 .195-IN-ID	28480	2190-0011
19	2190-0045	B	4	WASHER-LK HLCL NO. 2 .088-IN-ID	28480	2190-0045
20	2200-0103	2	4	SCREW-MACH 4-40 .25-IN-LG PAN-HD-POZI	00000	ORDER BY DESCRIPTION
21	2200-0105	4	99	SCREW-MACH 4-40 .312-IN-LG PAN-HD-POZI	00000	ORDER BY DESCRIPTION
22	2200-0107	6	1	SCREW-MACH 4-40 .375-IN-LG PAN-HD-POZI	00000	ORDER BY DESCRIPTION
23	2200-0141	B	1	SCREW-MACH 4-40 .312-IN-LG PAN-HD-POZI	00000	ORDER BY DESCRIPTION
24	2200-0149	6	10	SCREW-MACH 4-40 .625-IN-LG PAN-HD-POZI	00000	ORDER BY DESCRIPTION
25	2200-0153	2	4	SCREW-MACH 4-40 .875-IN-LG PAN-HD-POZI	00000	ORDER BY DESCRIPTION
26	2200-0166	7	3	SCREW-MACH 4-40 .312-IN-LG B2 DEG	00000	ORDER BY DESCRIPTION
27	2360-0111	0	5	SCREW-MACH 6-32 .188-IN-LG PAN-HD-POZI	00000	ORDER BY DESCRIPTION
28	2360-0113	2	13	SCREW-MACH 6-32 .25-IN-LG PAN-HD-POZI	00000	ORDER BY DESCRIPTION
29	2360-0114	3	5	SCREW-MACH 6-32 .25-IN-LG B2 DEG	00000	ORDER BY DESCRIPTION
30	2360-0115	4	37	SCREW-MACH 6-32 .312-IN-LG PAN-HD-POZI	00000	ORDER BY DESCRIPTION
31	2360-0116	5	4	SCREW-MACH 6-32 .312-IN-LG B2 DEG	00000	ORDER BY DESCRIPTION
32	2360-0117	6	10	SCREW-MACH 6-32 .375-IN-LG PAN-HD-POZI	00000	ORDER BY DESCRIPTION
33	2360-0119	B	10	SCREW-MACH 6-32 .438-IN-LG PAN-HD-POZI	00000	ORDER BY DESCRIPTION
34	2360-0122	3	1	SCREW-MACH 6-32 .5-IN-LG B2 DEG	00000	ORDER BY DESCRIPTION
35	2360-0197	2	11	SCREW-MACH 6-32 .375-IN-LG PAN-HD-POZI	00000	ORDER BY DESCRIPTION
35A	2360-0193	B	4	SCREW-MACH 6-32 .25-IN-LG PAN-HD-POZI	00000	ORDER BY DESCRIPTION
36	2360-0331	6	9	SCREW-MACH 6-32 .25-IN-LG PAN-HD-POZI	28480	2360-0331
37	2360-0333	B	26	SCREW-MACH 6-32 .25-IN-LG 100 DEG	28480	2360-0333
38	2360-0334	9	9	SCREW-MACH 6-32 .312-IN-LG 100 DEG	28480	2360-0334
39	2360-0360	1	2	SCREW-MACH 6-32 .438-IN-LG 100 DEG	28480	2360-0360
40	2420-0002	6	2	NUT-HEX-DBL-CHAM 6-32-THD .109-IN-THK	28480	2420-0002
41	0515-1331	5	16	SCREW-MACH M4x0.7x6mm FH 90	28480	0515-1331
42	0515-0896	5	8	SCREW-MACH M4x0.7x10mm FH 90	28480	0515-0896
43	2680-0129	B	6	SCREW-MACH 10-32 .312-IN-LG PAN-HD-POZI	00000	ORDER BY DESCRIPTION
44	3050-0066	B	2	WASHER-FL MTLCL NO. 6 .147-IN-ID	28480	3050-0066
45	3050-0105	6	4	WASHER-FL MTLCL NO. 4 .125-IN-ID	28480	3050-0105
46	3050-0227	3	7	WASHER-FL MTLCL NO. 6 .149-IN-ID	28480	3050-0227
47	1250-0915	B	1	CONTACT-RF CONN SER APC-N FEMALE	9D949	131-149
48	1250-1577	0	1	CONNECTOR-RF FEMALE TYPE N	28480	1250-1577
49	2190-0104	0	1	WASHER-LK INTL T 7/16 IN .439-IN-ID	28480	2190-0104
50	2360-0115	4		SCREW-MACH 6-32 .312-IN-LG PAN-HD-POZI	00000	ORDER BY DESCRIPTION
51	2950-0132	6	1	NUT-HEX-DBL-CHAM 7/16-28-THD .094-IN-THK	00000	ORDER BY DESCRIPTION
52	5040-0306	0	1	INSULATOR	28480	5040-0306
53	08340-00011	6	1	PANEL-REAR (AUX OUTPUT)	28480	08340-00011
54	08340-00056	9	1	DEFLECTOR-AIR	28480	08340-00056
55	08555-20093	5	1	CONTACT JACK	28480	08555-20093
56	08555-20094	6	1	BODY-BULKHEAD	28480	08555-20094
57	08761-2027	4	1	INSULATOR	28480	08761-2027
58	5021-5805	4	1	FRAME-FRONT (METRIC)	28480	5021-5805
59	08340-00001	4	1	CENTER DIVIDER	28480	08340-00001
60	08340-00002	5	1	CHASSIS-RF MOD (REAR)	28480	08340-00002
61	08340-00003	6	1	BRACKET- 20-30 MOUNT	28480	08340-00003
62	08340-00004	7	1	BRACKET-MOUNT TRANS	28480	08340-00004
63	08340-00005	B	1	SUPPORT-MOM BOARD	28480	08340-00005
64	08340-00020	7	1	DIVIDER PROCESSOR	28480	08340-00020
65	08340-00029	6	1	GUIDE PLATE-PC BOARDS	28480	08340-00029
66	08340-00031	0	1	SUPPORT-PC PROCESSOR	28480	08340-00031
67	08340-20051	6	1	SUPPORT-REAR CENTER	28480	08340-20051
68	08340-20234	7	1	FRAME (REAR) MOD (METRIC)	28480	08340-20234
69	08340-20054	9	1	SUPPORT-FRONT CENTER DIVIDER	28480	08340-20054
70	08340-20056	1	1	GUIDE-POWER SUPPLY	28480	08340-20056
71	08340-20236	9	1	STRUT-CORNER (TOP) (METRIC)	28480	08340-20236
72	08340-20238	1	3	STRUT-CORNER MOD (METRIC)	28480	08340-20238
73	85660-00004	6	1	BRACKET-PIVOT PROCESSOR	28480	85660-00004
74	85660-20190	3	1	HOUSING-20-30 MHZ	28480	85660-20190
75	86701-20006	2	1	GUIDE-FRONT PC	28480	86701-20006
76	0360-0037	7	6	TERMINAL-SLDR LUG PL-MTG FOR-#6-SCR	28480	0360-0037

See Introduction to this section for ordering information.

*Indicates factory selected value.

Figure 6-2. Miscellaneous Mechanical & Chassis Parts (1 of 9)

Reference Designation	HP Part Number	C D	Qty	Description	Mfr Code	Mfr Part Number
77	1251-4223	1	10	CONTACT-CONN U/W-POST-TYPE FEM CRP	28480	1251-4223
78	1251-6594	3	1	CONNECTOR HOUSING- 5 FEMALE IR	28480	1251-6594
79	8120-0579	2	1	CABLE-SHLD 22AWG 5-CNDCT JGK-JKT	28480	8120-0579
80	8150-0005	2	1	WIRE 22AWG BK 300V PVC 7X30 105C	28480	8150-0005
81	5001-0440	1	2	TRIM-SIDE F.F	28480	5001-0440
82	5040-7201	8	4	FOOT-BOTTOM	28480	5040-7201
83	5040-7202	9	1	TRIM STRIP (TOP)	28480	5040-7202
84	5061-9435	8	1	COVER FM TOP (METRIC)	28480	5061-9435
85	5061-9447	2	1	COVER FM BOTTOM (METRIC)	28480	5061-9447
86	5061-9462	1	1	COVER SIDE (METRIC)	28480	5061-9462
87	5061-9517	7	1	COVER FM PERFORATED (METRIC)	28480	5061-9517
88	5061-2033	8	1	INFO TRAY ASSY KIT	28480	5061-2033
89	08340-00023	0	1	DRESS PANEL-KEYBOARD	28480	08340-00023
90	08340-00074	1	1	HOLDER-PC COVER	28480	08340-00074
91	08340-00040	1	1	HOLDER-POWER SUPPLY BOARDS	28480	08340-00040
92	08340-00060	5	1	PLATE-CAP HOLDER	28480	08340-00060
93	08340-00061	6	1	HOLDER-CAP HOLDER	28480	08340-00061
94	08340-90201	6	1	INFO CARD #1	28480	08340-90201
95	08340-90202	7	1	INFO CARD #2	28480	08340-90202
96	85660-00025	1	1	SHOCK MOUNT (TOP)	28480	85660-00025
97	85660-00027	3	1	INSULATOR-HEAT SINK	28480	85660-00027
98	86701-00028	6	1	SPRING-FLAT	28480	86701-00028
99	1990-0720	1	1	DISPLAY-SPECIAL .1 HI	28480	1990-0720
100	8160-0226	0	12	RFI RND STR .050D	28480	8160-0226
101	08340-00006	9	1	SUPPORT-PC RECT.	28480	08340-00006
102	08340-00008	1	1	CHASSIS RF MOD (FRONT)	28480	08340-00008
103	08340-00064	9	1	POCKET (Holds Cal. Constant Data)	28480	08340-00064
104	6960-0009	1	1	Hole Plug .531-D-HOLE	28480	6960-0009
105	0380-0644	4	2	Standoff-Hex .400-IN-LG 6-32 THD	28480	0380-0644
106	2200-0164	5	10	SCREW-MACH 4-40 .188-IN-LG	28480	2200-0164
107	5021-3208	7	1	Housing-machined	28480	5021-3208
108	86701-00029	7	1	Baffle-Air Top	28480	86701-00029
109	86701-00024	2	1	Skoop Air	28480	86701-00024
110	86701-00030	0	1	Baffle-Air Bottom	28480	86701-00030
111	08340-00067	2	1	COVER-RECT. BOARD	28480	08340-00067
112	08340-00018	3	1	Fan Filter	28480	08340-00018
113	08340-00017	2	1	Grill Air	28480	08340-00017
114	3030-0152	1	2	SCREW-SET 4-40 .312-IN-LG SMALL CUP PT	28480	3030-0152
115	08340-00016	1	1	Fan Housing-Bottom	28480	08340-00016
116	08340-00012	7	1	Fan Housing-Top	28480	08340-00012
117	08340-00014	9	1	Fan Grill Housing	28480	08340-00014
118	1520-0230	3	4	Shock Mount	28480	1520-0230
119	08340-00016	1	1	Base Plate-Fan	28480	08340-00016
120	85660-20092	4	4	Snubber-Shock Mount	28480	85660-20092
121	2360-0196	1	4	Screw-Mach 6-32 .375-IN-LG 100 DEG	28480	2360-0196
122	2190-0009	4	2	WASHER-LK INT T NO. 8 .168-IN-ID	28480	2190-0009
123	2510-0051	6	2	SCREW-MACH 8-32 .625-IN-LG PAN-HD-POZI	28480	2510-0051
124	0360-0043	5	1	TERMINAL-SLDR LUG PL-MTG FOR-NO. 6-SCR	28480	0360-0043
125	1251-6796	7	1	CONN-POST TYPE	28480	1251-6796
126	0360-1632	0	4	TERMINAL-SLDR LUG LK-MTG FOR-//3/B-SCR	28480	0360-1632
127	0362-0227	1	2	CONNECTOR-SGL CONT SKT 1.14-MM-BSC-SZ	28480	0362-0227
128	1250-0083	1	8	CONNECTOR-RF BNC FEM SGL-HOLE-FR 50-OHM	28480	1250-0083
129	1250-0102	5	3	CONNECTOR-RF BNC FEM SGL-HOLE-FR 50-OHM	28480	1250-0102
130	1251-0064	0	1	CONNECTOR 25-PIN F D SERIES	28480	1251-0064
131	1251-2942	7	2	CONNECTOR-RACK & PANEL LOCK	28480	1251-2942
132	1251-3653	9	26	CONNECTOR CONTACT FEMALE .025	28480	1251-3653
133	1251-6781	0	1	CONNECTOR RECEPTACLE 3 MALE CONTACT	28480	1251-6781
134	1251-7374	9	1	CONNECTOR HOUSING-28 FEMALE 2R	28480	1251-7374
135	2190-0016	3	4	WASHER-LK INTL T 3/8 IN .377-IN-ID	28480	2190-0016
136	2190-0068	5	3	WASHER-LK INTL T 1/2 IN .505-IN-ID	28480	2190-0068
137	2190-0104	0	1	WASHER-LK INTL T 7/16 IN .439-IN-ID	28480	2190-0104
138	2950-0001	8	8	NUT-HEX-DBL-CHAM 3/8-32-THD .094-IN-THK	00000	ORDER BY DESCRIPTION
139	2950-0054	1	3	NUT-HEX-DBL-CHAM 1/2-28-THD .125-IN-THK	00000	ORDER BY DESCRIPTION
140	08340-00010	5	1	REAR PANEL	28480	08340-00010

See introduction to this section for matching information.

*Indicates factory selected value

Figure 6-2. Miscellaneous Mechanical & Chassis Parts (2 of 9)

Reference Designation	HP Part Number	C D	Qty	Description	Mfr Code	Mfr Part Number
MISCELLANEOUS MECHANICAL & CHASSIS PARTS						
1	0340-0923	B	10	INSULATOR-BSHG NYLON	28480	0340-0923
2	0360-0037	7	10	TERMINAL-SLDR LUG PL-MTG FOR-#6-SCR	28480	0360-0037
3	0360-0042	4	3	TERMINAL-SLDR LUG PL-MTG FOR-#6-SCR	28480	0360-0042
4	0400-0082	B	2	GROMMET-CHAN NCH .09-IN-GRV-WD	28480	0400-0082
5	0400-0219	3	3	GROMMET-RND .5-IN-ID .093-IN-GRV-WD	28480	0400-0219
6	0520-0127	6	4	SCREW-MACH 2-56 .188-IN-LG PAN-HD-POZI	00000	ORDER BY DESCRIPTION
7	0570-0632	3	10	SCREW-SPCL 4-40 .312-IN-LG PAN-HD-POZI	00000	ORDER BY DESCRIPTION
8	0590-1251	6	4	NUT-HEX 15/32-32	00000	ORDER BY DESCRIPTION
9	1200-0043	B	5	INSULATOR-XSTR ALUMINUM	28480	1200-0043
10	1400-0031	B	3	CLAMP-CABLE .375-DIA .5-WD NYL	28480	1400-0031
11	1400-0249	0	9	CABLE TIE .062-.625-DIA .091-WD NYL	06383	PLT1M-8
12	1400-0510	B	4	CLAMP-CABLE .15-DIA .62-WD NYL	28480	1400-0510
13	1400-0907	7	2	CLAMP-CABLE .187-DIA .5-WD FRTD-NYLON	95987	3/16-HFR
14	1520-0205	2	3	SHOCK MOUNT .31 HGT.	28480	1520-0205
15	2190-0003	B	14	WASHER-LK HLCL NO. 4 .115-IN-ID	28480	2190-0003
16	2190-0006	1	15	WASHER-LK HLCL NO. 6 .141-IN-ID	28480	2190-0006
17	2190-0008	3	1	WASHER-LK EXT T NO. 6 .141-IN-ID	28480	2190-0008
18	2190-0011	B	6	WASHER-LK INTL T NO. 10 .195-IN-ID	28480	2190-0011
19	2190-0045	B	4	WASHER-LK HLCL NO. 2 .088-IN-ID	28480	2190-0045
20	2200-0103	2	4	SCREW-MACH 4-40 .25-IN-LG PAN-HD-POZI	00000	ORDER BY DESCRIPTION
21	2200-0105	4	99	SCREW-MACH 4-40 .312-IN-LG PAN-HD-POZI	00000	ORDER BY DESCRIPTION
22	2200-0107	6	1	SCREW-MACH 4-40 .375-IN-LG PAN-HD-POZI	00000	ORDER BY DESCRIPTION
23	2200-0141	B	1	SCREW-MACH 4-40 .312-IN-LG PAN-HD-POZI	00000	ORDER BY DESCRIPTION
24	2200-0149	6	10	SCREW-MACH 4-40 .625-IN-LG PAN-HD-POZI	00000	ORDER BY DESCRIPTION
25	2200-0153	2	4	SCREW-MACH 4-40 .875-IN-LG PAN-HD-POZI	00000	ORDER BY DESCRIPTION
26	2200-0166	7	3	SCREW-MACH 4-40 .312-IN-LG 82 DEG	00000	ORDER BY DESCRIPTION
27	2360-0111	0	5	SCREW-MACH 6-32 .188-IN-LG PAN-HD-POZI	00000	ORDER BY DESCRIPTION
28	2360-0113	2	13	SCREW-MACH 6-32 .25-IN-LG PAN-HD-POZI	00000	ORDER BY DESCRIPTION
29	2360-0114	3	5	SCREW-MACH 6-32 .25-IN-LG 82 DEG	00000	ORDER BY DESCRIPTION
30	2360-0115	4	37	SCREW-MACH 6-32 .312-IN-LG PAN-HD-POZI	00000	ORDER BY DESCRIPTION
31	2360-0116	5	4	SCREW-MACH 6-32 .312-IN-LG 82 DEG	00000	ORDER BY DESCRIPTION
32	2360-0117	6	10	SCREW-MACH 6-32 .375-IN-LG PAN-HD-POZI	00000	ORDER BY DESCRIPTION
33	2360-0119	B	10	SCREW-MACH 6-32 .438-IN-LG PAN-HD-POZI	00000	ORDER BY DESCRIPTION
34	2360-0122	3	1	SCREW-MACH 6-32 .5-IN-LG 82 DEG	00000	ORDER BY DESCRIPTION
35	2360-0197	2	11	SCREW-MACH 6-32 .375-IN-LG PAN-HD-POZI	00000	ORDER BY DESCRIPTION
35A	2360-0193	B	4	SCREW-MACH 6-32 .25-IN-LG PAN-HD-POZI	00000	ORDER BY DESCRIPTION
36	2360-0331	6	9	SCREW-MACH 6-32 .25-IN-LG PAN-HD-POZI	28480	2360-0331
37	2360-0333	B	26	SCREW-MACH 6-32 .25-IN-LG 100 DEG	28480	2360-0333
38	2360-0334	9	9	SCREW-MACH 6-32 .312-IN-LG 100 DEG	28480	2360-0334
39	2360-0360	1	2	SCREW-MACH 6-32 .438-IN-LG 100 DEG	28480	2360-0360
40	2420-0002	6	2	NUT-HEX-DBL-CHAM 6-32-THD .109-IN-THK	28480	2420-0002
41	0515-1331	5	16	SCREW-MACH M4x0.7x6mm FH 90	28480	0515-1331
42	0515-0896	5	8	SCREW-MACH M4x0.7x10mm FH 90	28480	0515-0896
43	2680-0129	B	6	SCREW-MACH 10-32 .312-IN-LG PAN-HD-POZI	00000	ORDER BY DESCRIPTION
44	3050-0066	B	2	WASHER-FL MTLN NO. 6 .147-IN-ID	28480	3050-0066
45	3050-0105	6	4	WASHER-FL MTLN NO. 4 .125-IN-ID	28480	3050-0105
46	3050-0227	3	7	WASHER-FL MTLN NO. 6 .149-IN-ID	28480	3050-0227
47	1250-0915	B	1	CONTACT-RF CONN SER APC-N FEMALE	9D949	131-149
48	1250-1577	0	1	CONNECTOR-RF FEMALE TYPE N	28480	1250-1577
49	2190-0104	0	1	WASHER-LK INTL T 7/16 IN .439-IN-ID	28480	2190-0104
50	2360-0115	4	1	SCREW-MACH 6-32 .312-IN-LG PAN-HD-POZI	00000	ORDER BY DESCRIPTION
51	2950-0132	6	1	NUT-HEX-DBL-CHAM 7/16-28-THD .094-IN-THK	00000	ORDER BY DESCRIPTION
52	5040-0306	0	1	INSULATOR	28480	5040-0306
53	08340-00011	6	1	PANEL-REAR (AUX OUTPUT)	28480	08340-00011
54	08340-00056	9	1	DEFLECTOR-AIR	28480	08340-00056
55	08555-20093	5	1	CONTACT JACK	28480	08555-20093
56	08555-20094	6	1	BODY-BULKHEAD	28480	08555-20094
57	08761-2027	4	1	INSULATOR	28480	08761-2027
58	5021-5805	4	1	FRAME-FRONT (METRIC)	28480	5021-5805
59	08340-00001	4	1	CENTER DIVIDER	28480	08340-00001
60	08340-00002	5	1	CHASSIS-RF MOD (REAR)	28480	08340-00002
61	08340-00003	6	1	BRACKET- 20-30 MOUNT	28480	08340-00003
62	08340-00004	7	1	BRACKET-MOUNT TRANS	28480	08340-00004
63	08340-00005	B	1	SUPPORT-MGM BOARD	28480	08340-00005
64	08340-00020	7	1	DIVIDER PROCESSOR	28480	08340-00020
65	08340-00029	6	1	GUIDE PLATE-PC BOARDS	28480	08340-00029
66	08340-00031	0	1	SUPPORT-PC PROCESSOR	28480	08340-00031
67	08340-20051	6	1	SUPPORT-REAR CENTER	28480	08340-20051
68	08340-20234	7	1	FRAME (REAR) MOD (METRIC)	28480	08340-20234
69	08340-20054	9	1	SUPPORT-FRONT CENTER DIVIDER	28480	08340-20054
70	08340-20056	1	1	GUIDE-POWER SUPPLY	28480	08340-20056
71	08340-20236	9	1	STRUT-CORNER (TOP) (METRIC)	28480	08340-20236
72	08340-20238	1	3	STRUT-CORNER MOD (METRIC)	28480	08340-20238
73	85660-00004	6	1	BRACKET-PIVOT PROCESSOR	28480	85660-00004
74	85660-20190	3	1	HOUSING-20-30 MHZ	28480	85660-20190
75	86701-20006	2	1	GUIDE-FRONT PC	28480	86701-20006
76	0360-0037	7	6	TERMINAL-SLDR LUG PL-MTG FOR-#6-SCR	28480	0360-0037

See introduction to this section for ordering information.

*Indicates factory selected value.

Figure 6-2. Miscellaneous Mechanical & Chassis Parts (1 of 9)

Reference Designation	HP Part Number	C D	Qty	Description	Mfr Code	Mfr Part Number
77	1251-4223	1	10	CONTACT-CONN U/W-POST-TYPE FEM CRP	28480	1251-4223
78	1251-6594	3	1	CONNECTOR HOUSING- 5 FEMALE IR	28480	1251-6594
79	8120-0579	2	1	CABLE-SHLD 22AWG 5-CNDCT JGK-JKT	28480	8120-0579
80	8150-0005	2		WIRE 22AWG BK 300V PVC 7X30 105C	28480	8150-0005
81	5001-0440	1	2	TRIM-SIDE F.F	28480	5001-0440
82	5040-7201	8	4	FOOT-BOTTOM	28480	5040-7201
83	5040-7202	9	1	TRIM STRIP (TOP)	28480	5040-7202
84	5061-9435	8	1	COVER FM TOP (METRIC)	28480	5061-9435
85	5061-9447	2	1	COVER FM BOTTOM (METRIC)	28480	5061-9447
86	5061-9462	1	1	COVER SIDE (METRIC)	28480	5061-9462
87	5061-9517	7	1	COVER FM PERFORATED (METRIC)	28480	5061-9517
88	5061-2033	8	1	INFO TRAY ASSY KIT	28480	5061-2033
89	08340-00023	0	1	DRESS PANEL-KEYBOARD	28480	08340-00023
90	08340-00074	1	1	HOLDER-PC COVER	28480	08340-00074
91	08340-00040	1	1	HOLDER-POWER SUPPLY BOARDS	28480	08340-00040
92	08340-00060	5	1	PLATE-CAP HOLDER	28480	08340-00060
93	08340-00061	6	1	HOLDER-CAP HOLDER	28480	08340-00061
94	08340-90211	7	1	INFO CARD #1	28480	08340-90211
95	08340-90212	8	1	INFO CARD #2	28480	08340-90212
96	85660-00025	1	1	SHOCK MOUNT (TOP)	28480	85660-00025
97	85660-00027	3	1	INSULATOR-HEAT SINK	28480	85660-00027
98	86701-00028	6	1	SPRING-FLAT	28480	86701-00028
99	1990-0720	1	1	DISPLAY-SPECIAL .1 HI	28480	1990-0720
100	8160-0226	0	12	RFIRND STR .050D	28480	8160-0226
101	08340-00006	9	1	SUPPORT-PC RECT.	28480	08340-00006
102	08340-00008	1	1	CHASSIS RF MOD (FRONT)	28480	08340-00008
103	08340-00064	9	1	POCKET (Holds Cal. Constant Data)	28480	08340-00064
104	6960-0009	1	1	Hole Plug .531-D-HOLE	28480	6960-0009
105	0380-0644	4	2	Standoff-Hex .400-IN-LG 6-32 THD	28480	0380-0644
106	2200-0164	5	10	SCREW-MACH 4-40 .188-IN-LG	28480	2200-0164
107	5021-3208	7	1	Housing-machined	28480	5021-3208
108	86701-00029	7	1	Baffle-Air Top	28480	86701-00029
109	86701-00024	2	1	Skoop Air	28480	86701-00024
110	86701-00030	0	1	Baffle-Air Bottom	28480	86701-00030
111	08340-00067	2		COVER-RECT. BOARD	28480	08340-00067
112	08340-00018	3		Fan Filter	28480	08340-00018
113	08340-00017	2		Grill Air	28480	08340-00017
114	3030-0152	1	2	SCREW-SET 4-40 .312-IN-LG SMALL CUP PT	28480	3030-0152
115	08340-00016	1	1	Fan Housing-Bottom	28480	08340-00016
116	08340-00012	7	1	Fan Housing-Top	28480	08340-00012
117	08340-00014	9		Fan Grill Housing	28480	08340-00014
118	1520-0230	3	4	Shock Mount	28480	1520-0230
119	08340-00016	1	1	Base Plate-Fan	28480	08340-00016
120	85660-20092	4	4	Snubber-Shock Mount	28480	85660-20092
121	2360-0196	1	4	Screw-Mach 6-32 .375-IN-LG 100 DEG	28480	2360-0196
122	2190-0009	4	2	WASHER-LK INT T NO. 8 .168-IN-ID	28480	2190-0009
123	2510-0051	6	2	SCREW-MACH 8-32 .625-IN-LG PAN-HD-POZI	28480	2510-0051
124	0360-0043	5		TERMINAL-SLDR LUG PL-MTG FOR-NO. 6-SCR	28480	0360-0043
125	1251-6796	7		CONN-POST TYPE	28480	1251-6796
126	0360-1632	0	4	TERMINAL-SLDR LUG LK-MTG FOR-#3/B-SCR	28480	0360-1632
127	0362-0227	1	2	CONNECTOR-SGL CONT SKT 1.14-MM-BSC-SZ	28480	0362-0227
128	1250-0083	1	8	CONNECTOR-RF BNC FEM SGL-HOLE-FR 50-OHM	28480	1250-0083
129	1250-0102	5	3	CONNECTOR-RF BNC FEM SGL-HOLE-FR 50-OHM	28480	1250-0102
130	1251-0064	0	1	CONNECTOR 25-PIN F D SERIES	28480	1251-0064
131	1251-2942	7	2	CONNECTOR-RACK & PANEL LOCK	28480	1251-2942
132	1251-3653	9	26	CONNECTOR CONTACT FEMALE .025	28480	1251-3653
133	1251-6781	0	1	CONNECTOR RECEPTACLE 3 MALE CONTACT	28480	1251-6781
134	1251-7374	9	1	CONNECTOR HOUSING-28 FEMALE 2R	28480	1251-7374
135	2190-0016	3	4	WASHER-LK INTL T 3/8 IN .377-IN-ID	28480	2190-0016
136	2190-0068	5	3	WASHER-LK INTL T 1/2 IN .505-IN-ID	28480	2190-0068
137	2190-0104	0	1	WASHER-LK INTL T 7/16 IN .439-IN-ID	28480	2190-0104
138	2950-0001	8	8	NUT-HEX-DBL-CHAM 3/8-32-THD .094-IN-THK	00000	ORDER BY DESCRIPTION
139	2950-0054	1	3	NUT-HEX-DBL-CHAM 1/2-28-THD .125-IN-THK	00000	ORDER BY DESCRIPTION
140	08340-00082	1	1	REAR PANEL	28480	08340-00082

See Introduction to this section for ordering information.

Indicates factory selected value.

Figure 6-2. Miscellaneous Mechanical & Chassis Parts (2 of 9)

Reference Designation	HP Part Number	C D	Qty	Description	Mfr Code	Mfr Part Number
141	3101-0163	5	1	SWITCH KIT	28480	3101-0163
142	9222-0090	9	1	Plastic Jacket (Holds Cal. Constant Data)	28480	9222-0090
143	08340-00070	7	1	BRACKET	28480	08340-00070

See introduction to this section for ordering information
 *Indicates factory selected value

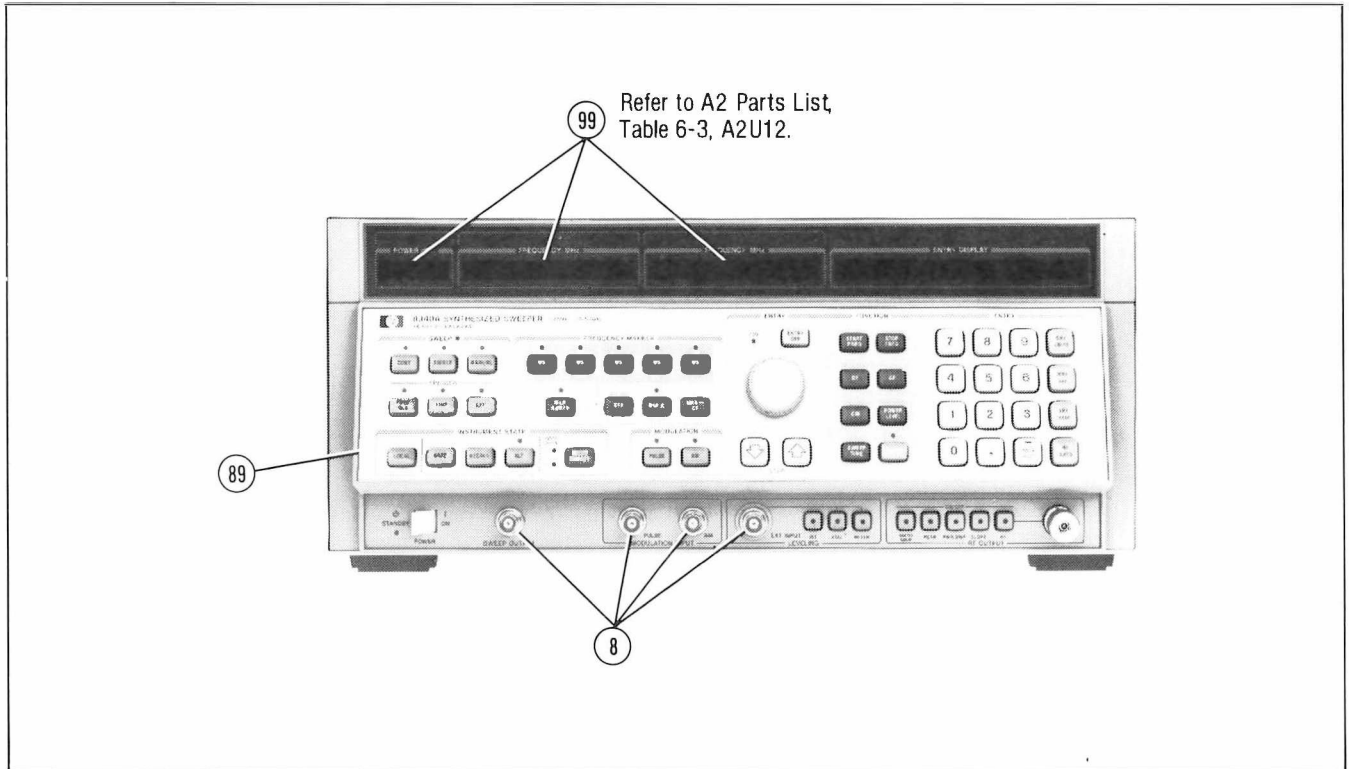

Figure 6-2. Miscellaneous Mechanical & Chassis Parts (3 of 9)

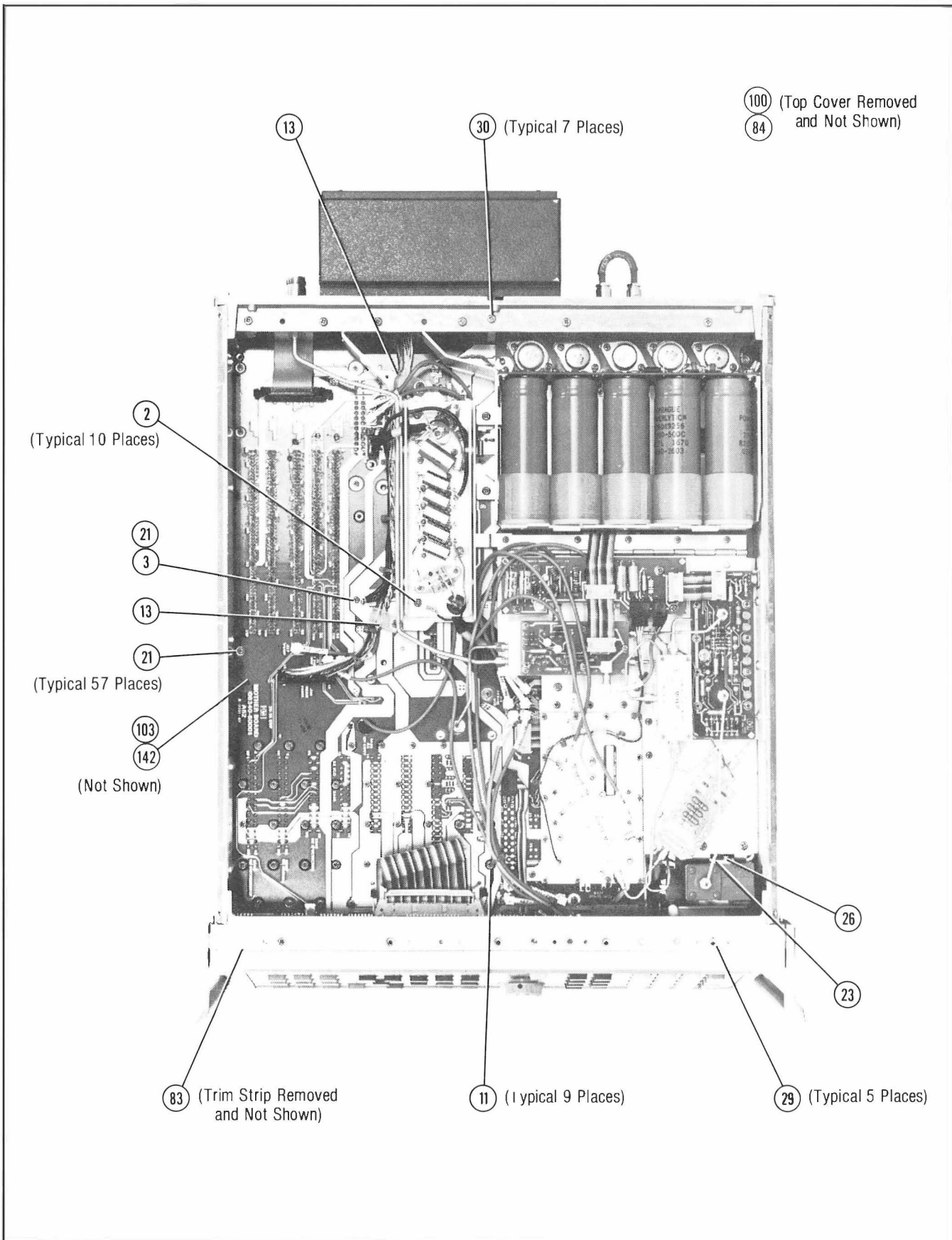

Figure 6-2. Miscellaneous Mechanical & Chassis Parts (4 of 9)

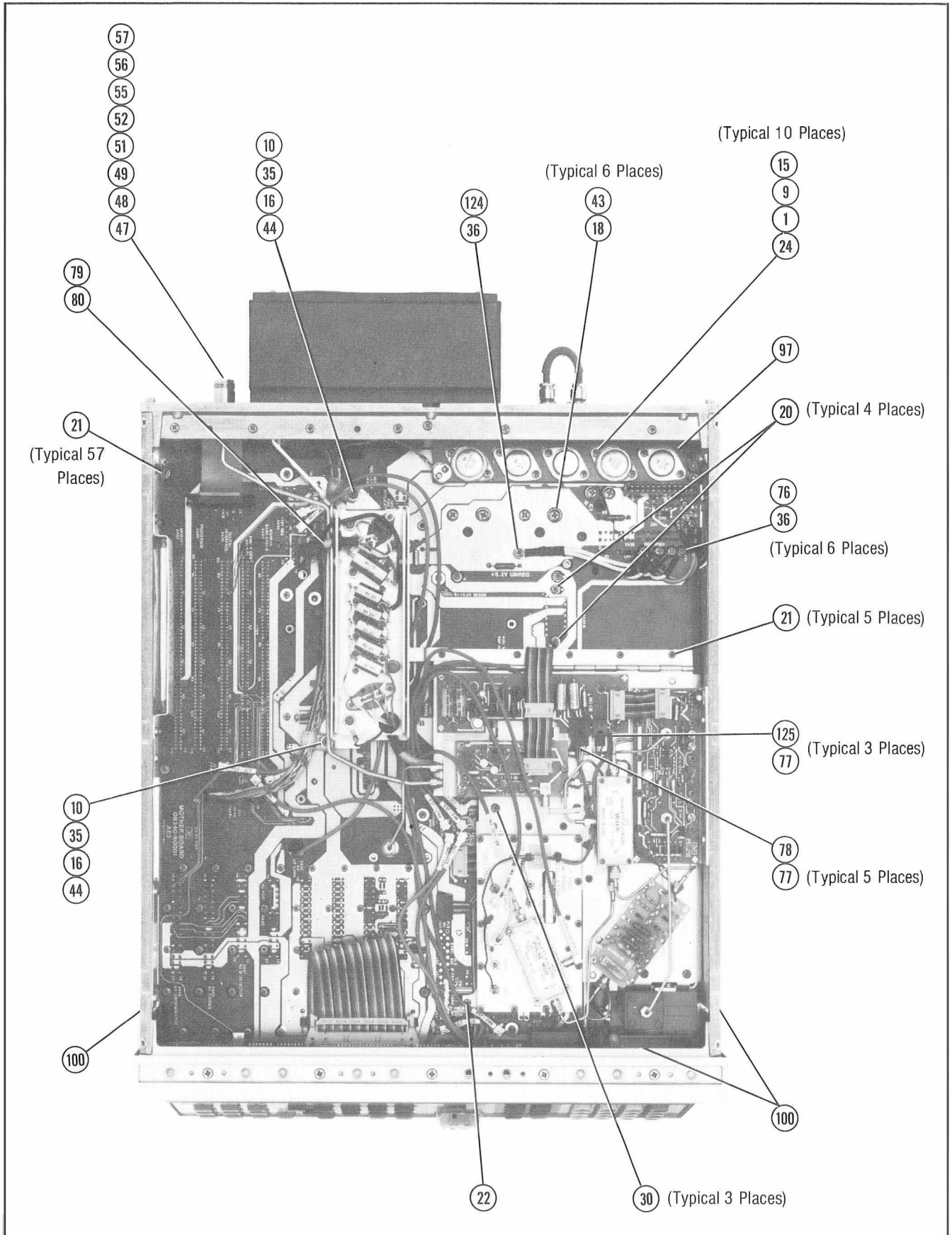

Figure 6-2. Miscellaneous Mechanical & Chassis Parts (5 of 9)

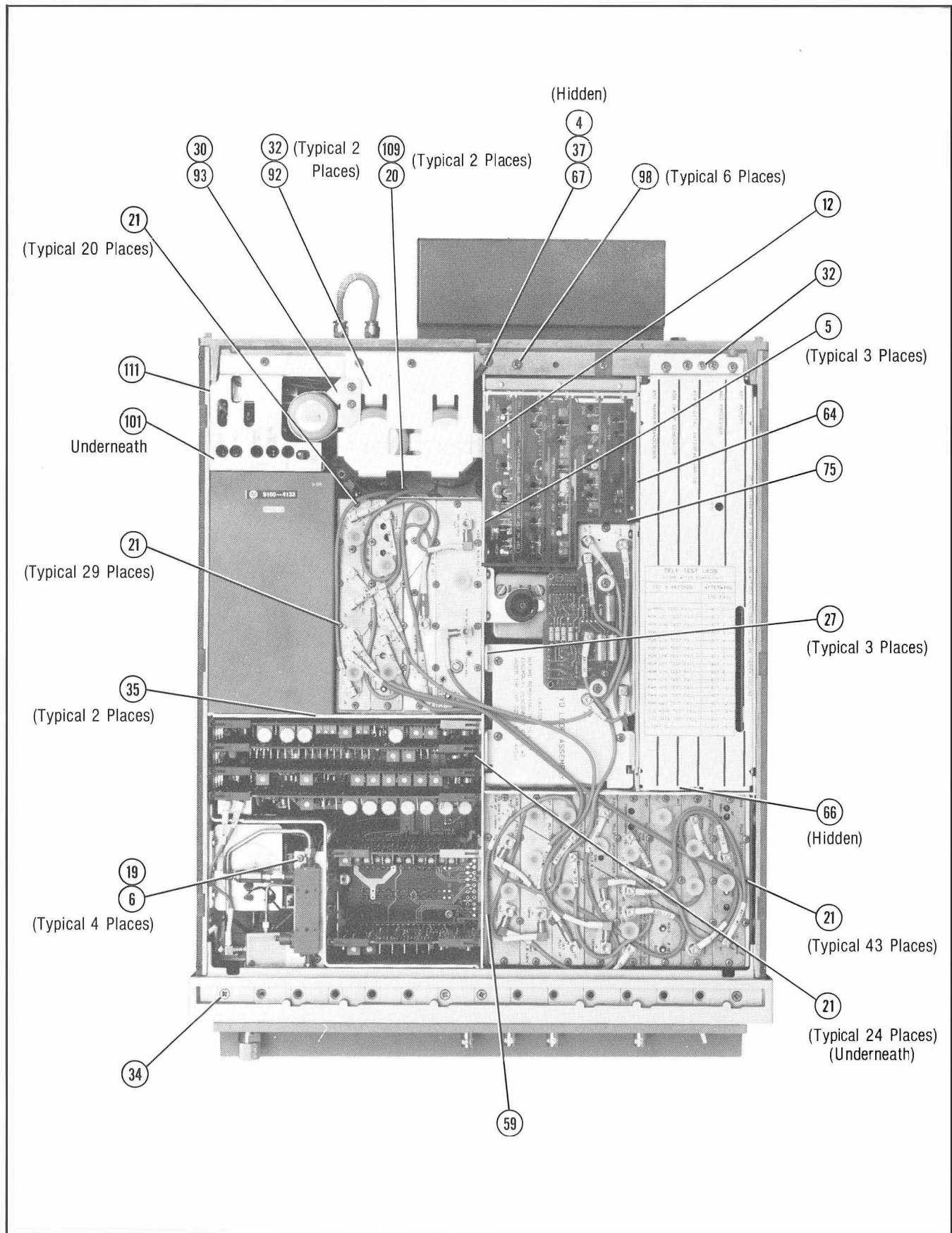

Figure 6-2. Miscellaneous Mechanical & Chassis Parts (6 of 9)

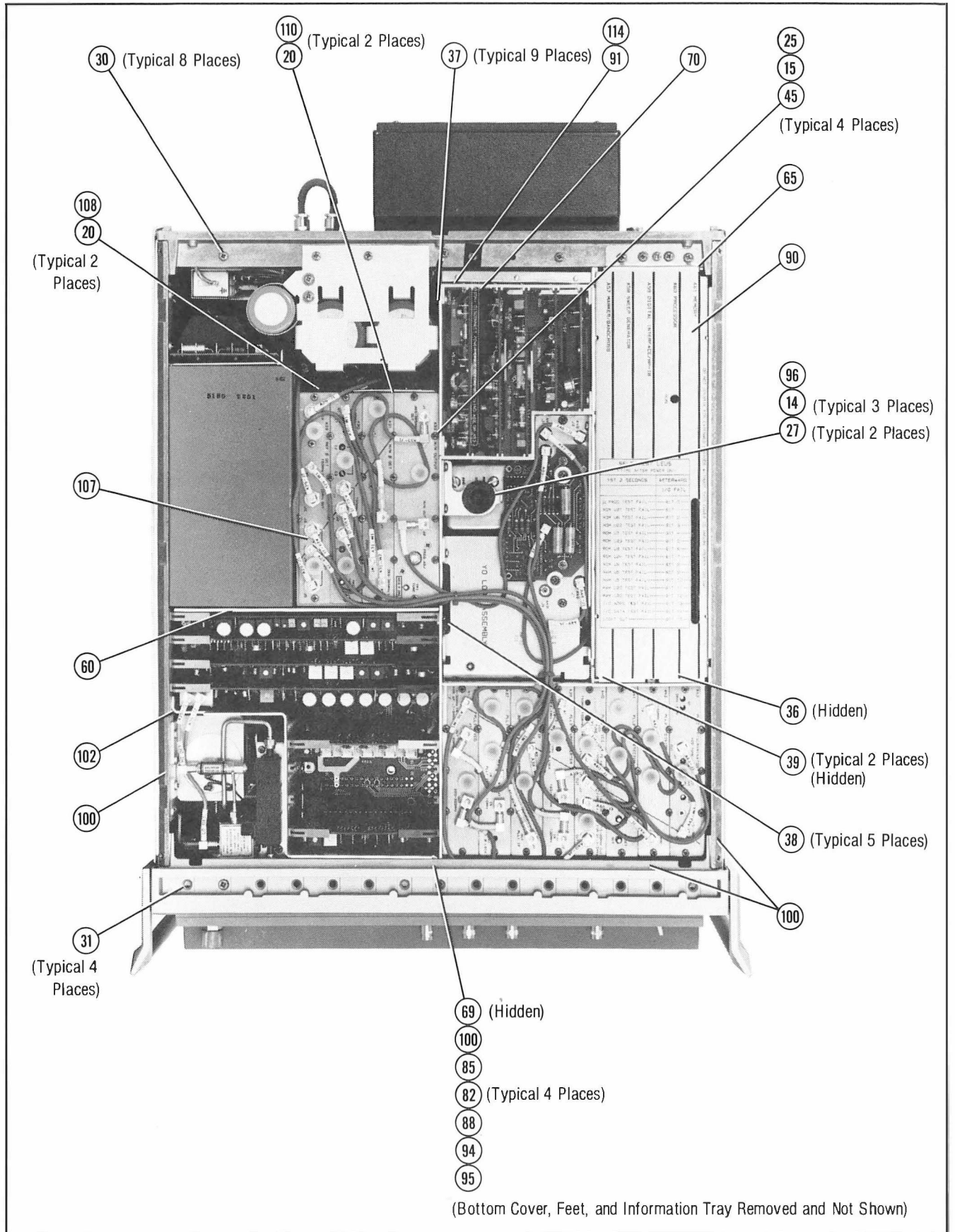

Figure 6-2. Miscellaneous Mechanical & Chassis Parts (7 of 9)

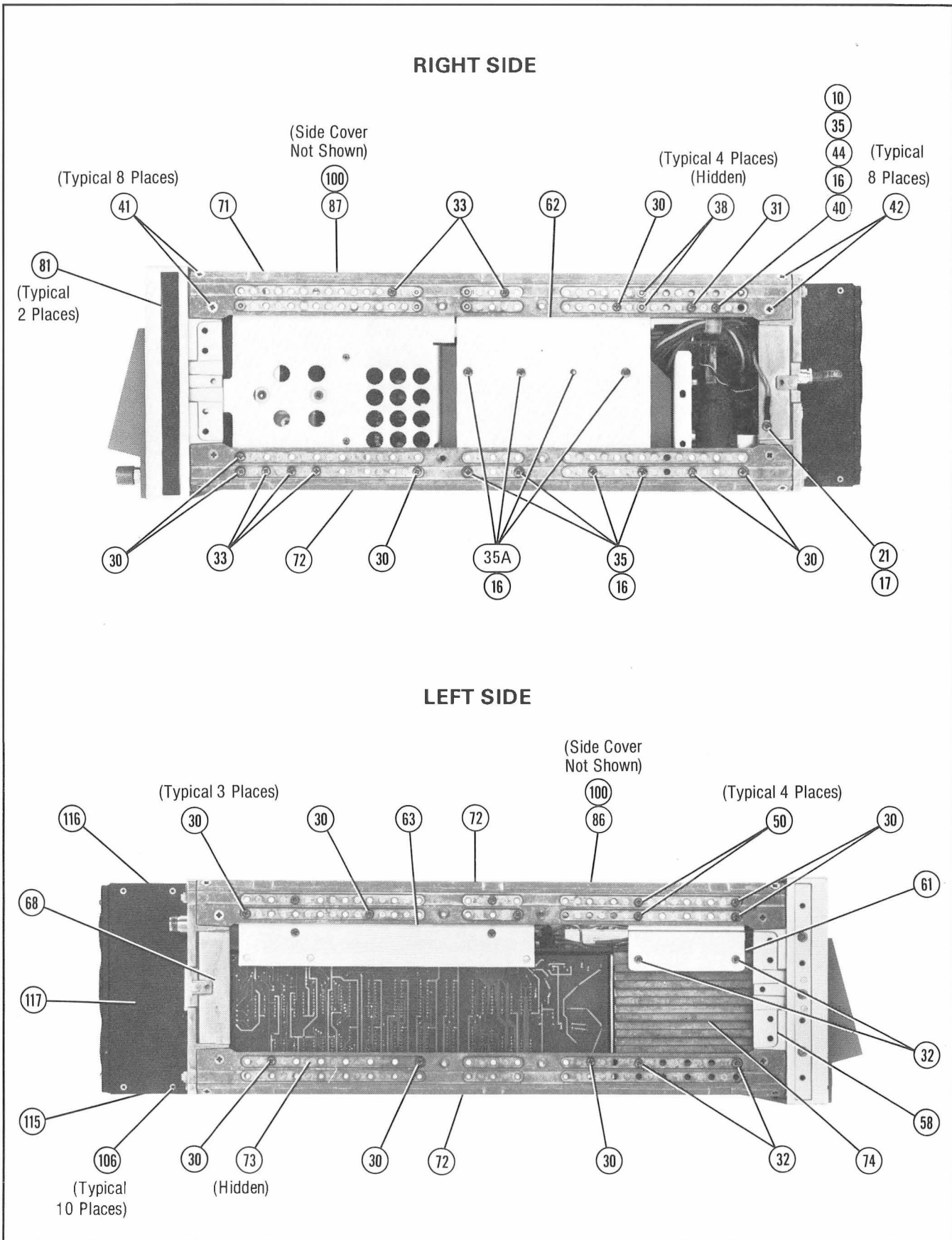

Figure 6-2. Miscellaneous Mechanical & Chassis Parts (8 of 9)

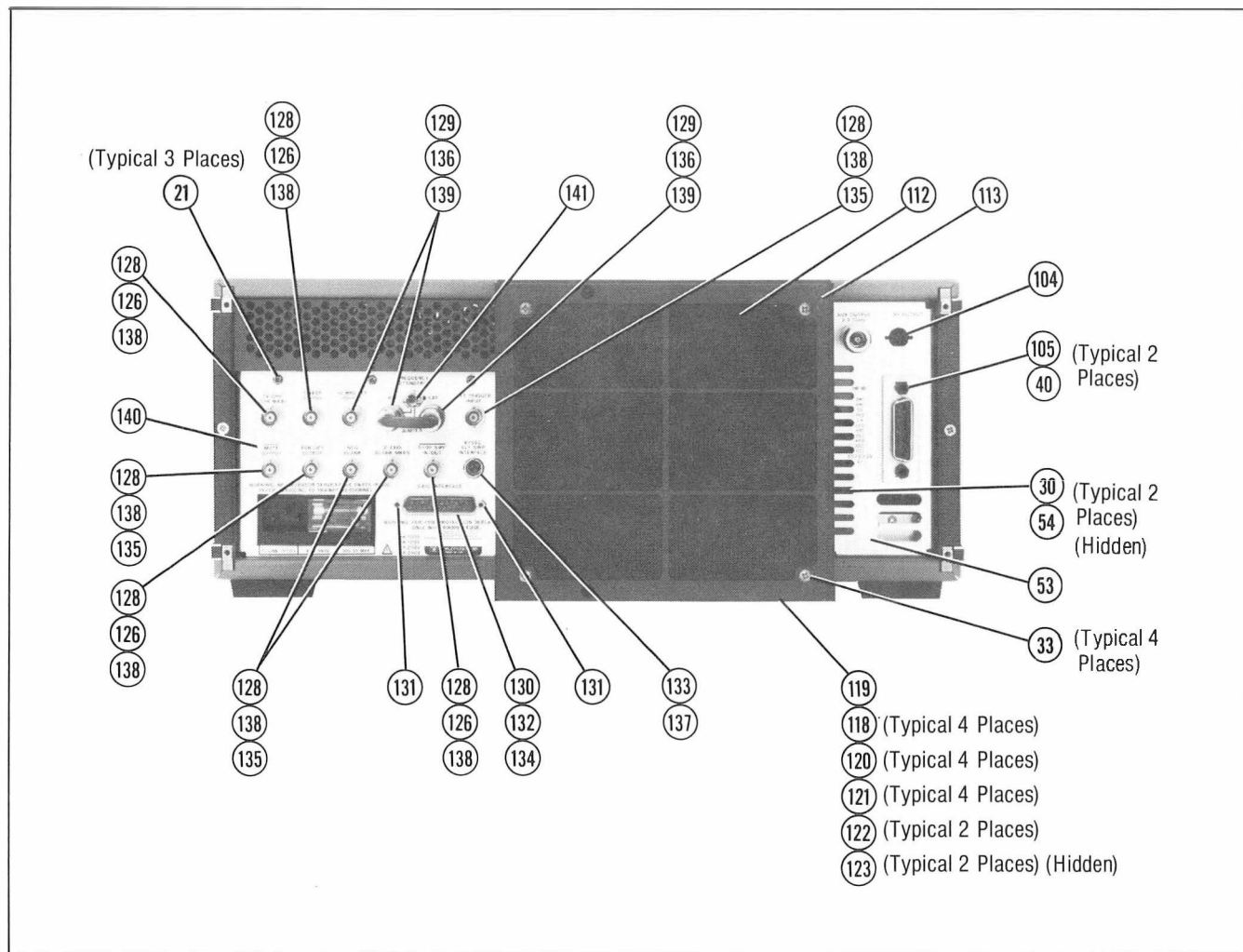

Figure 6-2. Miscellaneous Mechanical & Chassis Parts (9 of 9)

Reference Designation	HP Part Number	C D	Qty	Description	Mfr Code	Mfr Part Number
FRONT PANEL ATTACHING HARDWARE						
1	0360-0005	9	1	TERMINAL-SLDR LUG PL-MTG FOR-#8-SCR	28480	0360-0005
2	0510-1148	2	2	RETAINER-PUSH ON KB-TO-SHFT EXT	28480	0510-1148
3	0624-0264	2	16	SCREW-TPG 4-40 .312-IN-LG 82 DEG	00000	ORDER BY DESCRIPTION
4	1400-0249	0	2	CABLE TIE .062-.625-DIA .091-WD NYL	06383	PLTIM-8
5	2190-0016	3	2	WASHER-LK INTL T 3/8 IN .377-IN-ID	28480	2190-0016
6	2200-0105	4	7	SCREW-MACH 4-40 .312-IN-LG PAN-HD-POZI	00000	ORDER BY DESCRIPTION
7	2200-0113	4	5	SCREW-MACH 4-40 .625-IN-LG PAN-HD-POZI	00000	ORDER BY DESCRIPTION
8	2200-0115	6	6	SCREW-MACH 4-40 .75-IN-LG PAN-HD-POZI	00000	ORDER BY DESCRIPTION
9	2260-0009	3	2	NUT-HEX-W/LKWR 4-40-THD .094-IN-THK	00000	ORDER BY DESCRIPTION
10	2950-0043	8	2	NUT-HEX-DBL-CHAM 3/8-32-THD .094-IN-THK	00000	ORDER BY DESCRIPTION
11	08340-00024	1	1	SUB-PANEL KEYBOARD	28480	08340-00024
12	08340-00025	2	1	DRESS PANEL (LOWER)	28480	08340-00025
13	08340-00026	3	1	SUB-PANFL (LOWER) KEYBOARD	28480	08340-00026
14	08340-20078	7	1	BEZFL-KEYBOARD FIN	28480	08340-20078
15	1450-0615	9	1	Retainer	28480	1450-0615
16	08340-40002	9	1	LED Mount	28480	08340-40002
17	0370-2992	8	1	KNOB-BASE 1-1/8 JGK .252-IN-ID	28480	0370-2992
18	0590-1251	6	4	NUT-SPCLY 15/32-32-THD .1-IN-THK .562-W	28480	0590-1251
19	00310-48801	0	2	WASHER SHOULDER	28480	00310-48801
20	0360-1158	5	1	LUG	28480	0360-1158

See introduction to this section for ordering information
 *Indicates factory selected value

Figure 6-3. Front Panel Attaching Hardware (1 of 2)

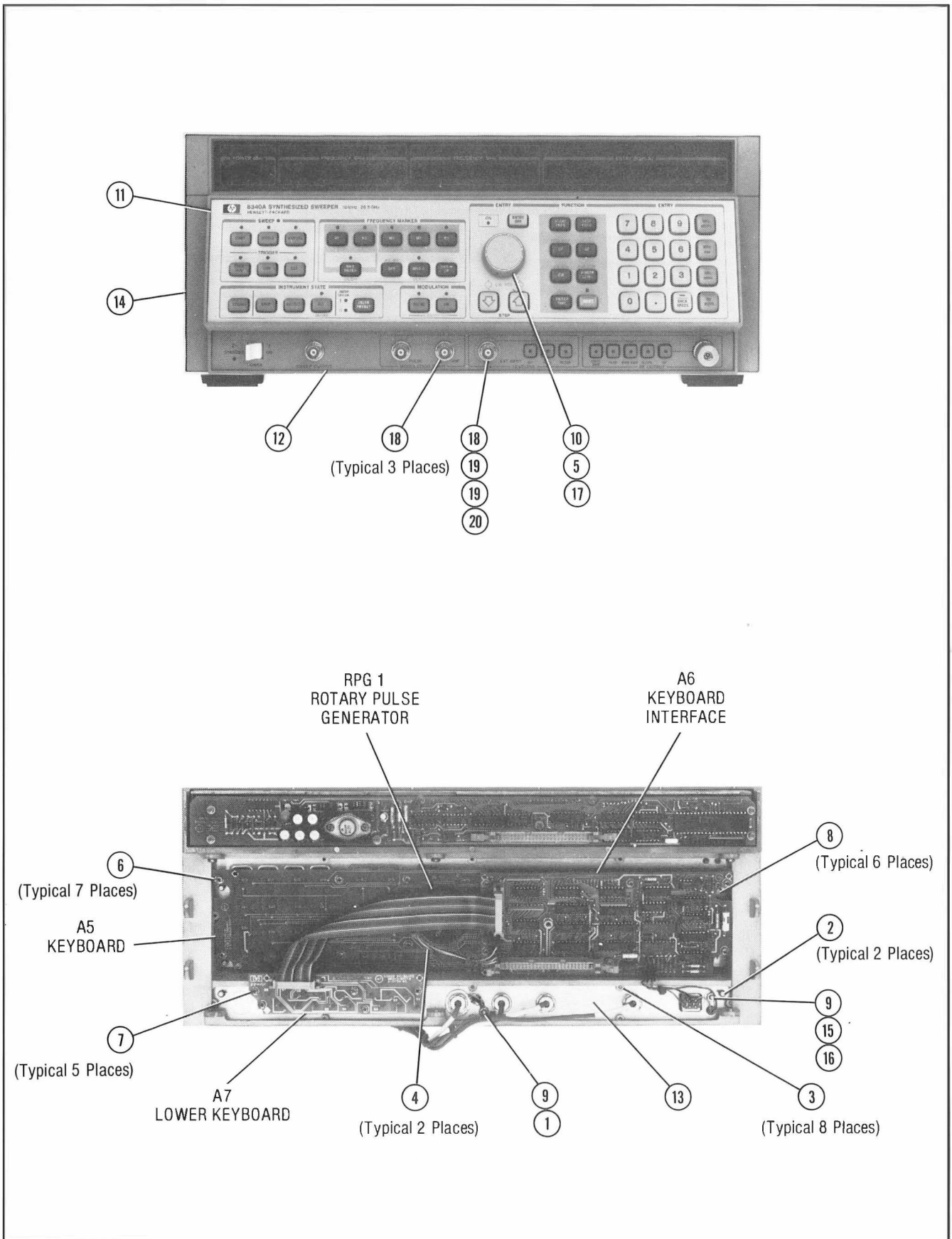

Figure 6-3. Front Panel Attaching Hardware (2 of 2)

Table 6-3. Replaceable Parts

Reference Designation	HP Part Number	C D	Qty	Description	Mfr Code	Mfr Part Number
1	0050-2141	1	1	<p>DISPLAY ASSEMBLY ATTACHING HARDWARE</p> <p>CASTING-AL CTR DISPLAY</p> <p>NOTE</p> <p>Replace with service kit 08340-60195.</p>	28480	0050-2141
2	0520-0127	6	5	SCREW-MACH 2-56 .188-IN-LG PAN-HD-POZI	00000	ORDER BY DESCRIPTION
3	0520-0136	7	2	SCREW-MACH 2-56 .625-IN-LG PAN-HD-POZI	00000	ORDER BY DESCRIPTION
4	0520-0139	0	8	SCREW-MACH 2-56 .875-IN-LG PAN-HD-POZI	00000	ORDER BY DESCRIPTION
5	0520-0174	3	8	SCREW-MACH 2-56 .25-IN-LG PAN-HD-POZI	00000	ORDER BY DESCRIPTION
6	0570-0189	5	6	SCREW-MACH 0-80 .125-IN-LG 82 DEG	00000	ORDER BY DESCRIPTION
7	2190-0014	1	7	WASHER-LK INTL T NO. 2 .089-IN-ID	28480	2190-0014
8	2190-0045	8	8	WASHER-LK HLCL NO. 2 .088-IN-ID	28480	2190-0045
9	3050-0098	6	8	WASHER-FL MTLC NO. 2 .094-IN-ID	28480	3050-0098
10	4040-1912	5	1	WINDOW-DISPLAY	28480	4040-1912
11	08340-00036	5	1	INSULATOR-HEAT CONDUCTIVE	28480	08340-00036
12	08340-20057	2	1	FRAME-DISPLAY/MACH	28480	08340-20057
				<p>NOTE</p> <p>Replace with service kit 08340-60195.</p>		
13	2360-0115	4	3	SCREW	28480	2360-0115

See introduction to this section for ordering information
 *Indicates factory selected value

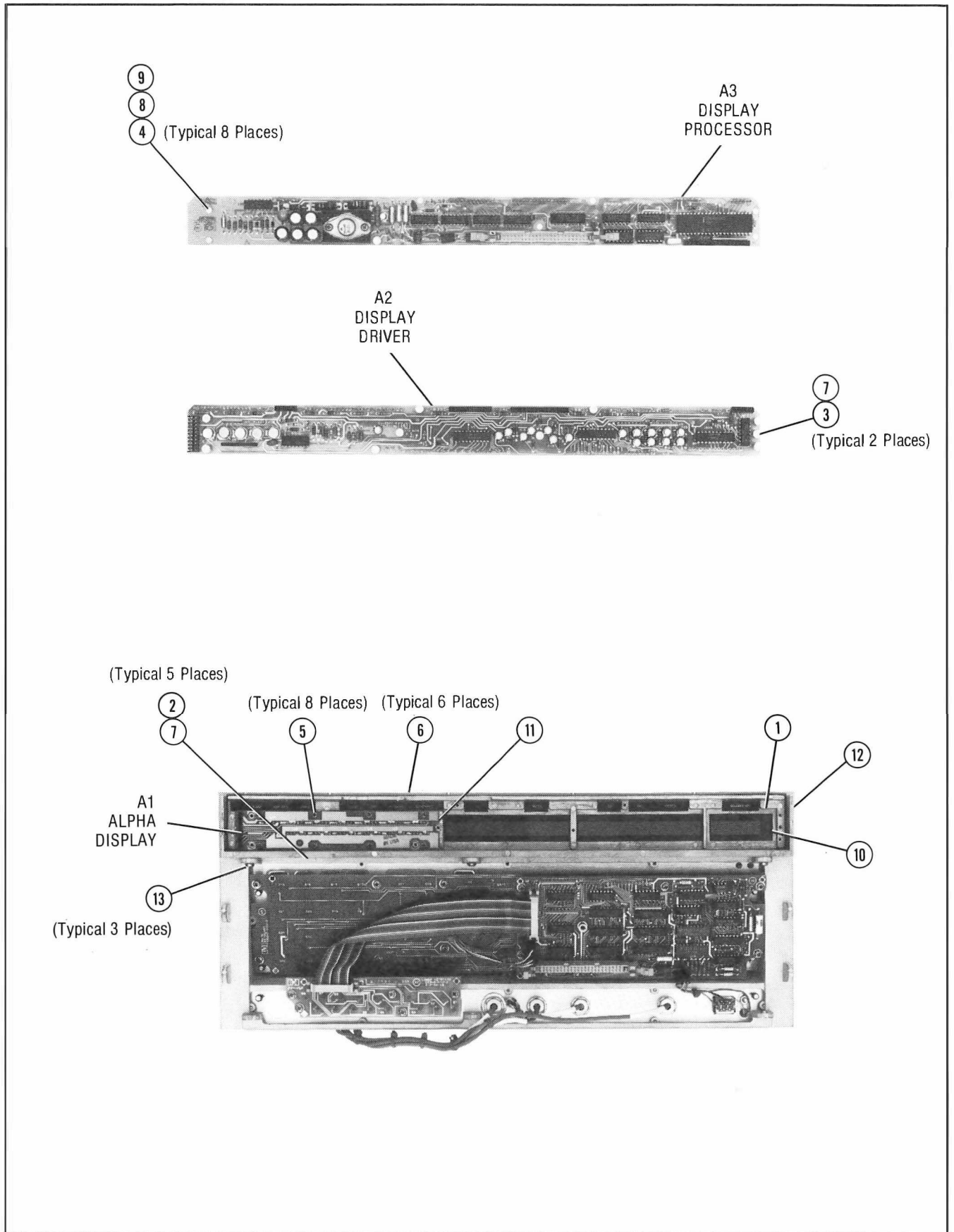

Figure 6-4. Display Assembly Attaching Hardware (2 of 2)

Reference Designation	HP Part Number	C D	Qty	Description	Mfr Code	Mfr Part Number
YO LOOP SECTION ATTACHING HARDWARE						
1	0360-0452	0	2	TERMINAL-SLDR LUG PL-MTG FOR-#10-SCR	28480	0360-0452
2	0520-0164	1	2	SCREW-MACH 2-56 .25-IN-LG 82 DEG	00000	ORDER BY DESCRIPTION
3	1250-0258	2	2	A49J1,J2 CONNECTOR-RF MALE SMB	28480	1250-0258
4	1250-0691	7	4	A49J3,J4 A48J1,2- CONNECTOR-RF MALE SMB	28480	1250-0691
5	2190-0124	4	2	WASHER-LK INTL T NO. 10 .195-IN-ID	28480	2190-0124
6	2200-0103	2	13	SCREW-MACH 4-40 .25-IN-LG PAN-HD-POZI	00000	ORDER BY DESCRIPTION
7	2200-0147	4	2	SCREW-MACH 4-40 .5-IN-LG PAN-HD-POZI	00000	ORDER BY DESCRIPTION
8	2200-0165	6	23	SCREW-MACH 4-40 .25-IN-LG 82 DEG	00000	ORDER BY DESCRIPTION
9	2360-0331	6	4	SCREW-MACH 6-32 .25-IN-LG PANHD POZI	28480	2360-0331
10	2360-0333	8	2	SCREW-MACH-6-32 .25-IN-LG 100 DEG	28480	2360-0333
11	2950-0078	9	2	NUT-HEX-DBL-CHAM 10-32-THD .067-IN-THK	28480	2950-0078
12	3050-0105	6	2	WASHER-FL MTLT NO. 4 .125-IN-ID	28480	3050-0105
13	3050-0907	6	4	WASHER-SHLDR NO. 10 .194-IN-ID	28480	3050-0907
14	08340-00032	1	1	DECK-YO LOOP	28480	08340-00032
15	08340-00049	0	1	COVER-SAMPLER	28480	08340-00049
16	08340-00050	3	1	COVER-PHASE LOCK	28480	08340-00050
17	08340-20072	1	1	HOUSING-YT P/L	28480	08340-20072
18	85660-20088	8	2	STUD-YTO LOOP	28480	85660-20088
19	85660-20100	5	2	EXTRACTOR	28480	85660-20100
20	86701-00054	8	1	SPACER-SAMPLER	28480	86701-00054
21	2190-0003	8	2	WASHER-LK HLCL NO. 4 .115-IN-ID	28480	2190-0003
22	1250-1142	5	1	WASHER-LK INTL T 1/2 IN .26-IN-ID	28480	1250-1142
23	1250-1143	6	1	NUT-RF CONNECTOR-SERIES SM A	28480	1250-1143

Figure 6-5. YO Loop Section Attaching Hardware (1 of 4)

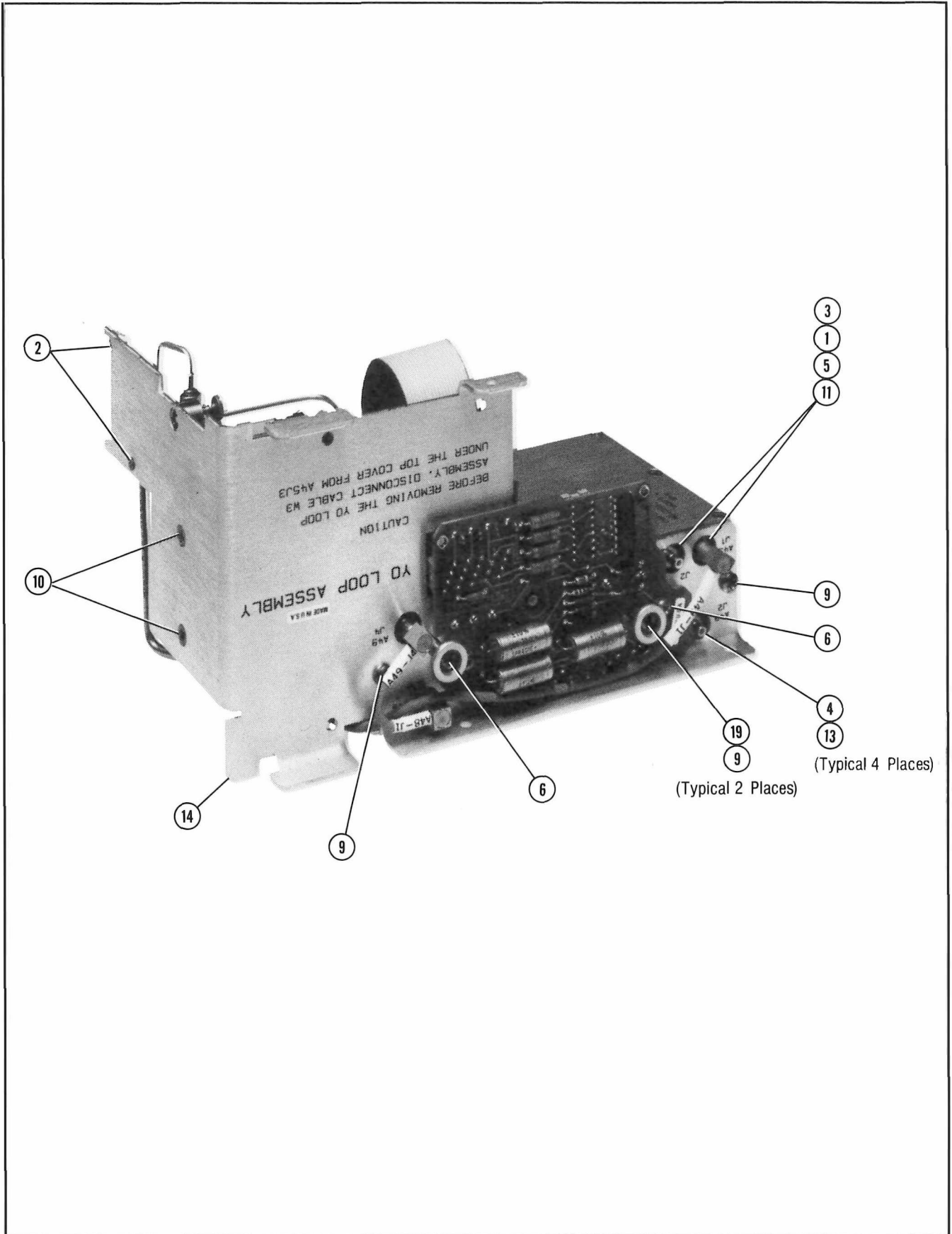

Figure 6-5. YO Loop Section Attaching Hardware (2 of 4)

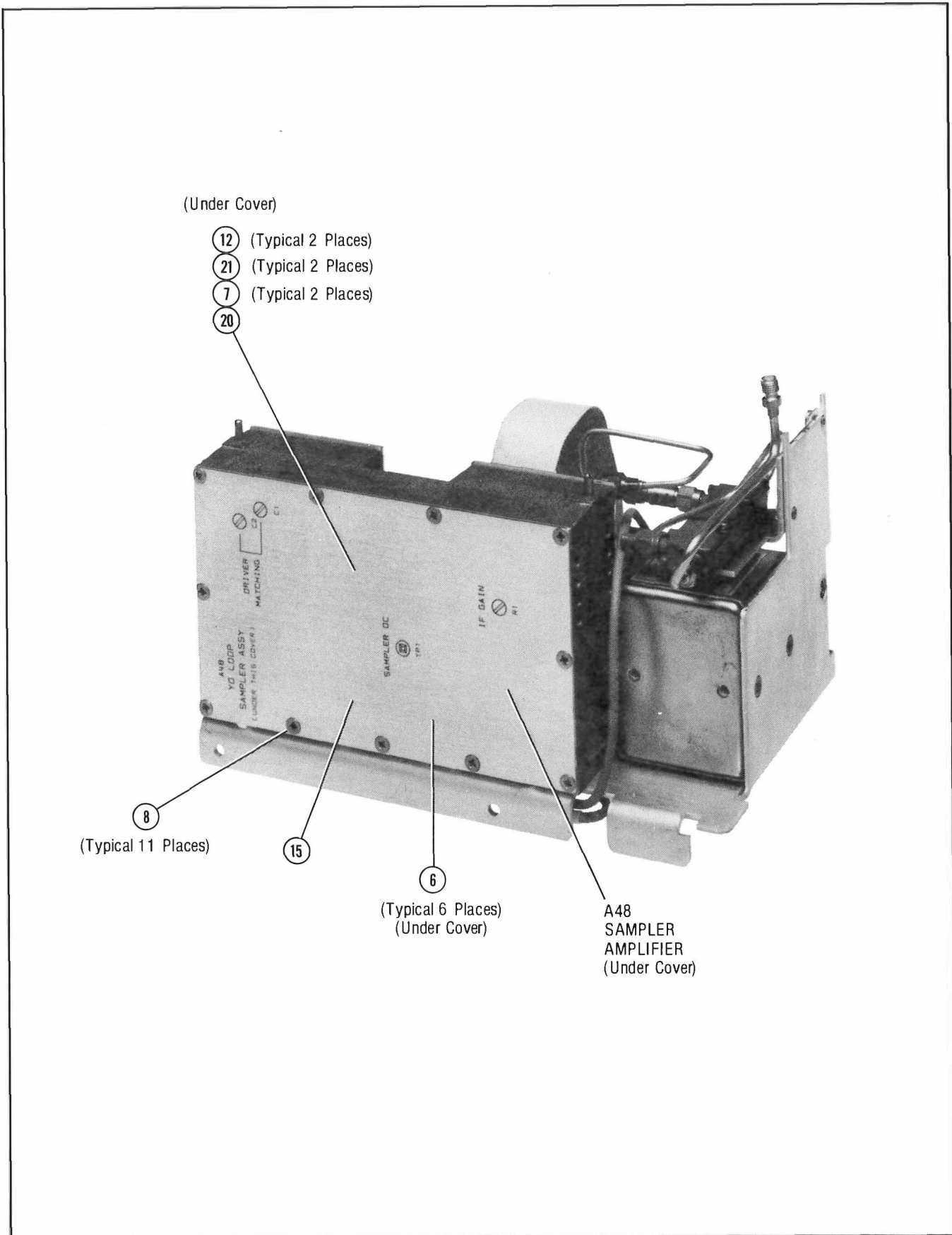

Figure 6-5. YO Loop Section Attaching Hardware (3 of 4)

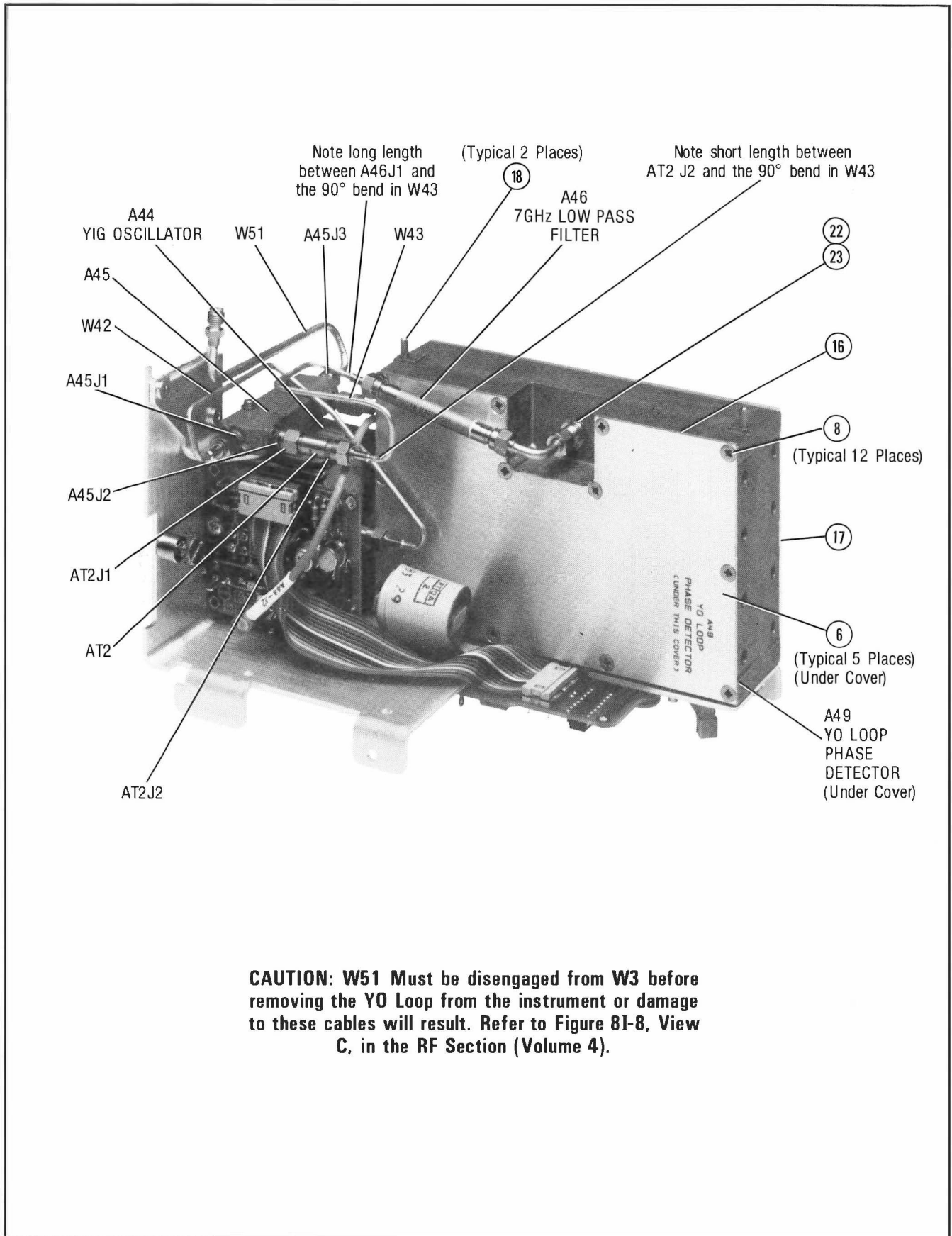

Figure 6-5. YO Loop Section Attaching Hardware (4 of 4)

Reference Designation	HP Part Number	C D	Qty	Description	Mfr Code	Mfr Part Number
RF SECTION ATTACHING HARDWARE						
(REFER TO FIGURE 6-3.)						
1	0520-0128	7	2	SCREW-MACH 2-56 .25-IN-LG PAN-HD-POZI	00000	ORDER BY DESCRIPTION
2	0520-0136	7	4	SCREW-MACH 2-56 .625-IN-LG PAN-HD-POZI	00000	ORDER BY DESCRIPTION
3	2190-0003	8	20	WASHER-LK HLCL NO. 4 .115-IN-ID	28480	2190-0003
4	2190-0006	1	4	WASHER-LK HLCL NO. 6 .141-IN-ID	28480	2190-0006
5	2190-0045	8	6	WASHER-LK HLCL NO. 2 .088-IN-ID	28480	2190-0045
6	2200-0091	7	8	SCREW-MACH 4-40 .562-IN-LG PAN-HD-POZI	00000	ORDER BY DESCRIPTION
7	2200-0105	4	5	SCREW-MACH 4-40 .312-IN-LG PAN-HD-POZI	00000	ORDER BY DESCRIPTION
8	2200-0141	8	1	SCREW-MACH 4-40 .312-IN-LG PAN-HD-POZI	00000	ORDER BY DESCRIPTION
9	2200-0143	0	7	SCREW-MACH 4-40 .375-IN-LG PAN-HD-POZI	00000	ORDER BY DESCRIPTION
10	2200-0166	7	1	SCREW-MACH 4-40 .312-IN-LG 82 DEG	00000	ORDER BY DESCRIPTION
11	2260-0001	5	4	NUT-HEX-DBL-CHAM 4-40-THD .094-IN-THK	28480	2260-0001
12	2360-0115	4	2	SCREW-MACH 6-32 .312-IN-LG PAN-HD-POZI	00000	ORDER BY DESCRIPTION
13	2360-0207	5	8	SCREW-MACH 6-32 .875-IN-LG PAN-HD-POZI	00000	ORDER BY DESCRIPTION
14	2360-0334	9	6	SCREW-MACH 6-32 .312-IN-LG 100 DEG	28480	2360-0334
15	08340-00007	0	1	DECK-MICROCIRCUIT MOUNT	28480	08340-00007
16	08340-00045	6	1	BRACKET-PMI MOUNT	28480	08340-00045

Figure 6-6. RF Section Attaching Hardware (1 of 2)

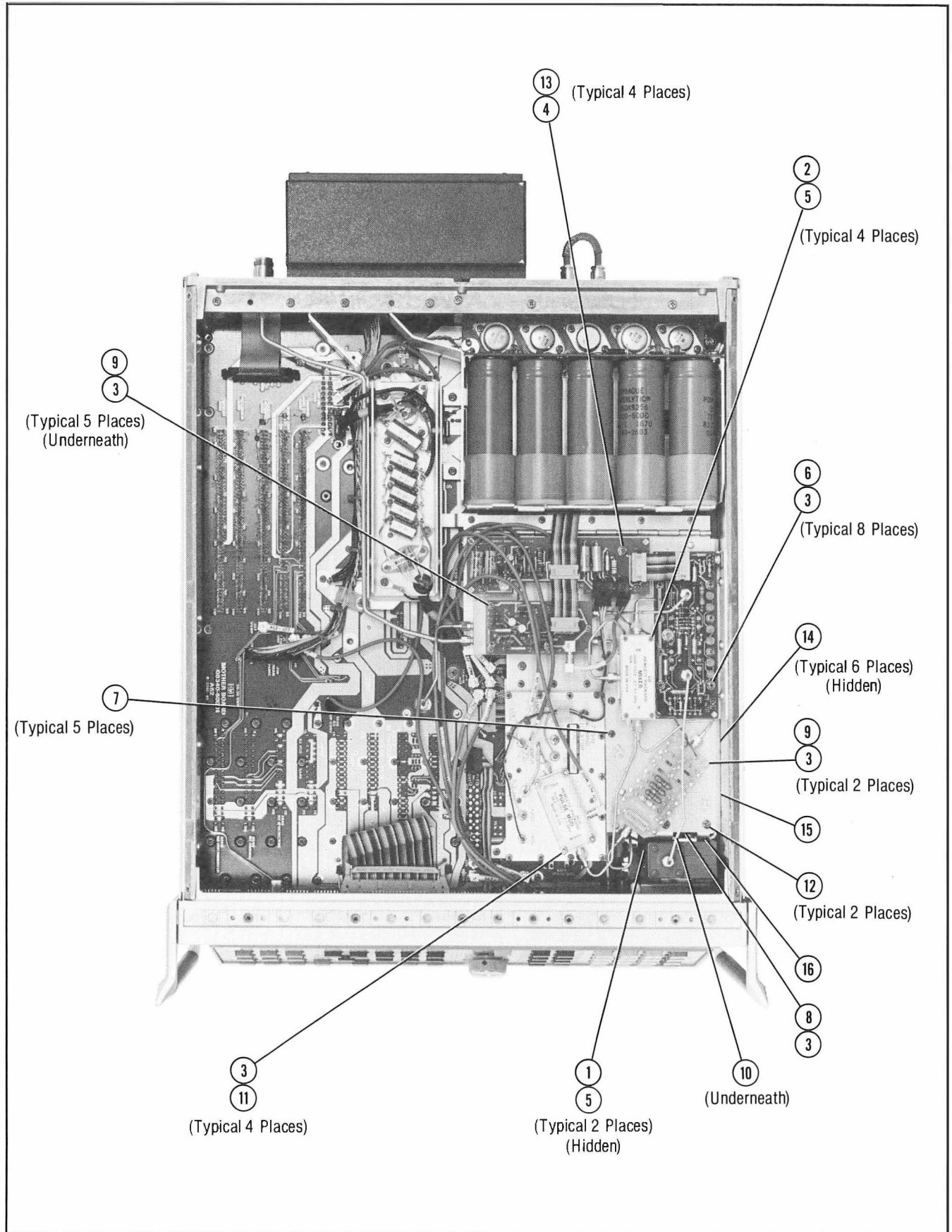

Figure 6-6. RF Section Attaching Hardware (2 of 2)

Reference Designation	HP Part Number	C D	Qty	Description	Mfr Code	Mfr Part Number
REFERENCE-M/N SECTION ATTACHING HARDWARE						
1	2200-0103	2	6	SCREW-MACH 4-40 .25-IN-LG PAN-HD-POZI	00000	ORDER BY DESCRIPTION
2	2200-0105	4	24	SCREW-MACH 4-40 .312-IN-LG PAN-HD-POZI	00000	ORDER BY DESCRIPTION
3	5021-3208	7	1	HOUSING-MACH	28480	5021-3208
4	08340-60039	4	1	BOARD ASSY-REF ASSY MO	28480	08340-60039
5	86701-00024	2	1	SCOOP-AIR	28480	86701-00024
6	86701-00029	7	1	BAFFLE-AIR (TOP)	28480	86701-00029
7	86701-00030	0	1	BAFFLE-AIR (BOTTOM)	28480	86701-00030

Figure 6-7. Reference — M/N Section Attaching Hardware (1 of 2)

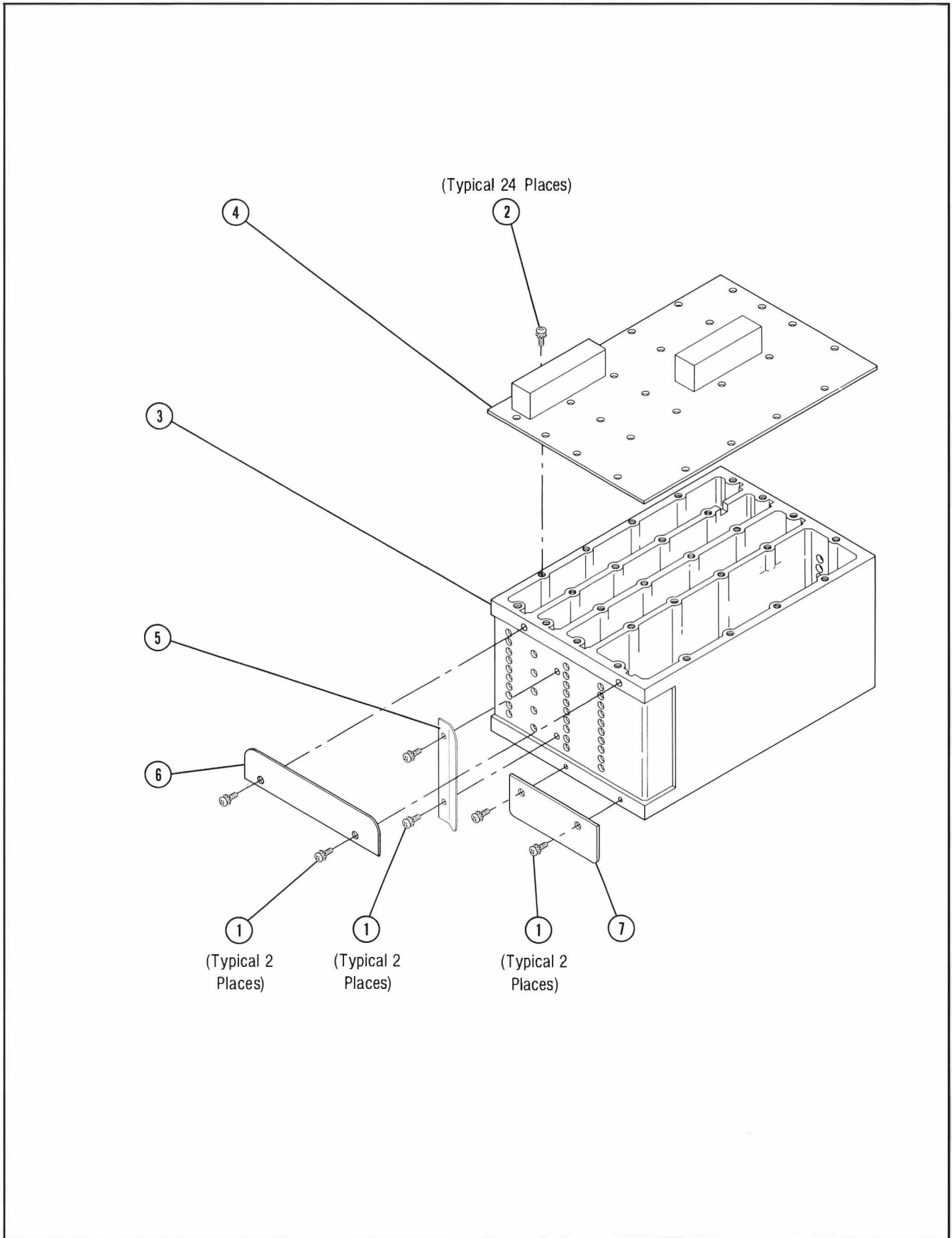

Figure 6-7. Reference — M/N Section Attaching Hardware (2 of 2)

